

Project: _____	AIA# _____
Item #: _____ Qty: _____	SIS# _____
Model #: _____	

## Soda Gun Holders

Patented. For more information visit:  
<https://www.glastender.com/patents>

C-SHA-4, C-SHA-4-ED, C-SHA-6, C-SHA-6-ED,  
C-SHB-4, C-SHB-4-ED, C-SHB-6, C-SHB-6-ED,  
C-SHP-4, C-SHP-4-ED, C-SHP-6, C-SHP-6-ED

### Standard Features

- All stainless steel construction
- Designed to house the manifold of Wunder-Bar<sup>®</sup> or Schroeder America<sup>™</sup> 8 to 14 button soda guns
- Includes integral drip pan with radius corners for easy cleaning
- Built-in holder for soda gun
- Top cover is removable for access to the soda manifold
- Allows you to dictate the soda gun location
- Eliminates the need for tubing bundles above the work surface
- Designed to mount to at least one other piece of underbar equipment (there is no provision for leg mounting)
- Pre-aligned mounting holes and bolts ensure a secure and exact fit when mounting adjoining units
- Extra deep “-ED” models available to align with extra-deep style ice bins

### Specifications

#### Drain

- 1/2" welded tailpiece

#### Materials

- All stainless steel construction



Intertek  
4004503

Conforms to ANSI/NSF STD 2

C-SHA-6

Underbar installation instructions: <https://www.glastender.com/support/documents/manuals/underbar-installation-instructions>

Cleaning & care instructions: <https://www.glastender.com/support/documents/manuals/general-cleaning-and-care-instructions-for-stainless-steel>

### Installation Details



Figure 1

Figure 2

Figure 3

Figure 4

Figure 5

Figure 6

1. Remove three cover screws and the cover (Figure 1).
2. Remove the manifold containment bracket by removing the thumbscrew (Figure 2).
3. Plumb drip pan drain, which may be more convenient to do while the cover is removed.
4. Connect soda tubing from inside housing to soda gun manifold (Figure 3).
5. Insert manifold and lines into the housing while placing the soda gun line in the front cut-out. Secure the manifold in place with the bracket and thumbscrew removed in step two (Figure 4).
6. Reattach cover with the three screws removed in step one (Figure 5).
7. Set the soda gun in the holder (Figure 6).
8. Installation complete.

Glastender, Inc. • 5400 North Michigan Road • Saginaw, MI • 48604-9780  
989.752.4275 • 800.748.0423 • Fax 989.752.4444  
www.glastender.com

Approval/Notes:

Specifications subject to change without notice. For current specifications please visit our website.

# Choice Soda Gun Holders

## Dimensional Information

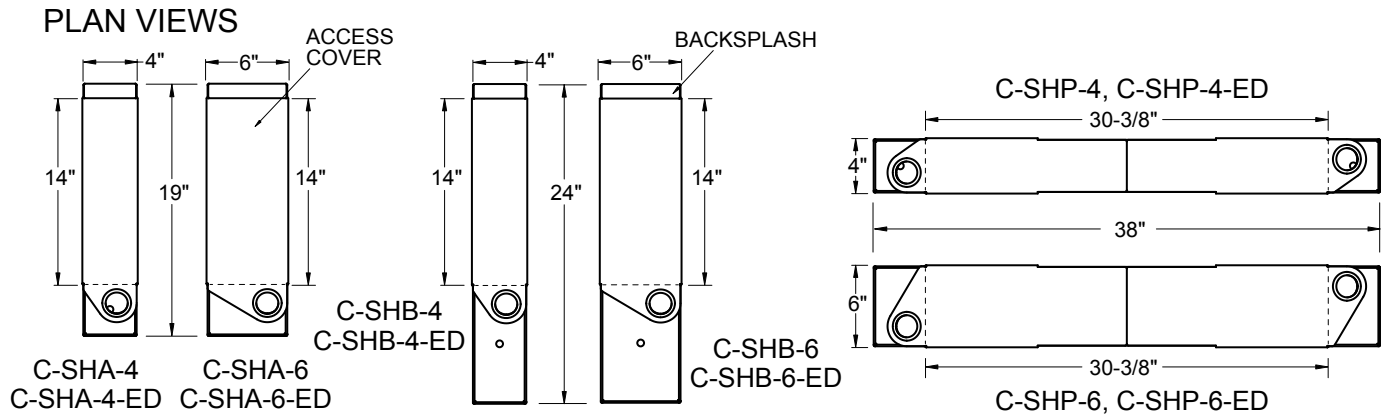

### FRONT VIEWS

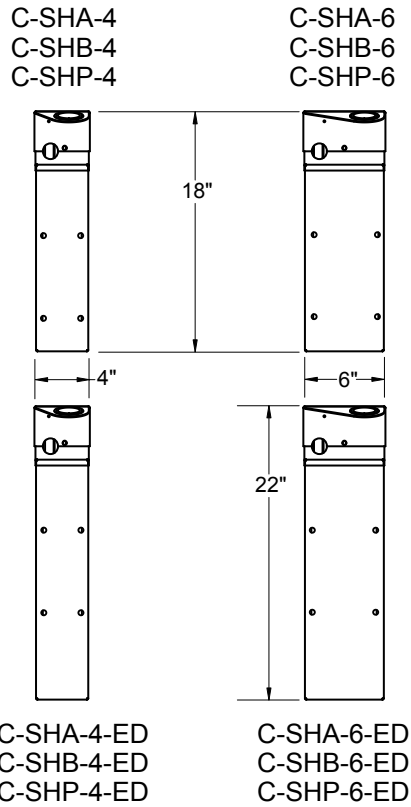

### SIDE ELEVATIONS

