

VITO VL

Spec sheet



Functionality:

VITO VL cleans your oil in an easy and hygienic way. VITO is placed in the hot oil and filters out suspended particles and bitter substances without supervision. After the set time (standard 4.5 min) VITO stops automatically and your oil is ready to be used. VITO features the remote tracking solution VITOconnect. VITOconnect gives you an online overview of productivity, services and updates.

Features:

- ▲ For all fryers up to 70 lbs
- ▲ Pressure flow filtration
- ▲ Automatic filtration - VITO stops after set filtration time
- ▲ Automatic safety off - VITO has integrated tilt-switch & heat protection
- ▲ Up to 16 filtration cycles in a row to filter multiple fryers
- ▲ Made out of stainless steel (1.4301) and other food safe materials
- ▲ Pump-filter unit and drip pan can be cleaned in dishwasher
- ▲ Network connection (WiFi)
- ▲ Acoustic and visual signals

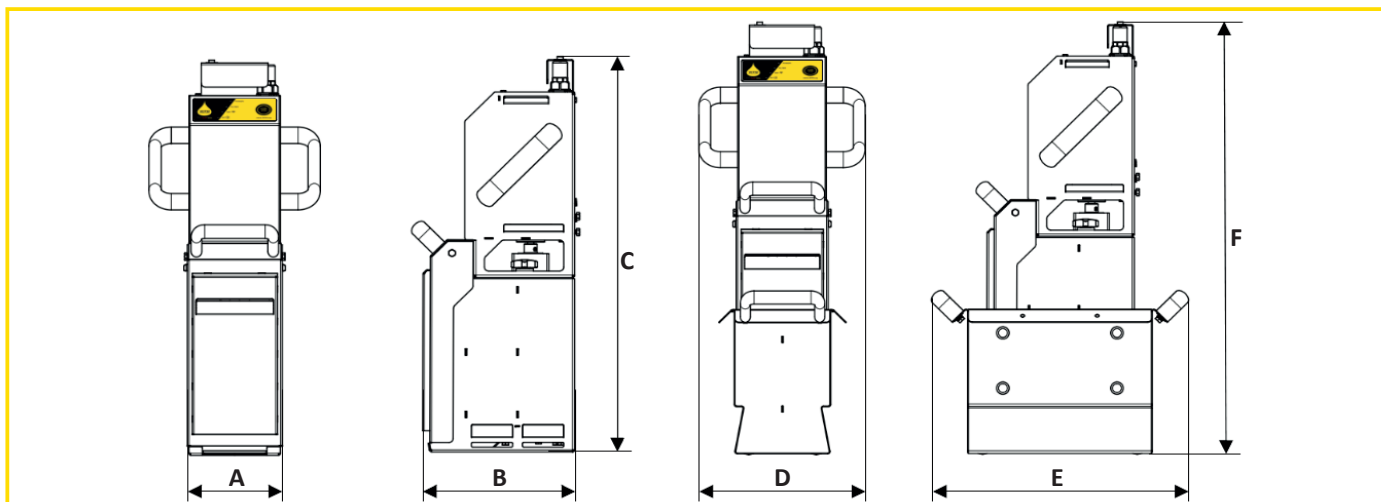

VITO VL technical Data:

	Width A	Depth B	Height C			Width D	Depth E	Height F
	4.6 in	7.4 in	19.8 in			8.3 in	12.8 in	22.2 in
Filtration power	Filtration efficiency	Particle capacity	Work cycle	Suction depth	Max. power	Power connection	Fuse inside	Protection
up to 220 lbs/min	200 µin effective/ 785 µin nominal	5.5 lbs*	4.5 min (adjustable)	~17.7 in	500 W	100 - 120 V, single phase	8 AT	Protection Earth (PE)
Total weight	Weight	Temperature	Material					
23.2 lbs (with drip pan)	19.4 lbs (without drip pan)	max. 392 °F	Stainless steel 1.4301					

*regular bread crumbs

Extensions & Accessories:

- ▲ Access to <https://connect.vito.ag>
- ▲ Brackets to accommodate all fryer types
- ▲ Particle filters

V 1.1



VITO Fryfilter, Inc.
Arlington Heights, IL 60005
P: +1-847-859-0398
info@vitofryfilter.com
www.vitofryfilter.com