



Replacement ice machines

for Symphony Plus™ 414 ice and water dispensers

Replacement air- or water-cooled ice machine with up to 425 lb (193 kg) daily production of popular Chewblet® ice

- R290 refrigerant has a low environmental impact and nominal global warming potential (GWP)
- water and energy efficient
- stainless steel evaporator and auger
- quiet production without noisy harvest cycles

Warranty

- 3 years parts and labor, 5 years compressor parts

Accessories

Installation of an in-line water filtration system is recommended



Bacterial retentive water filter system
(refer to form# 8320) (item# 01233659)
___ ea. replacement water filter kit (item# 01244615)

Carbonless water filter kit (refer to form# 1058)
(Item# CARBONLESSHICAPSYS)
___ ea. extra primary water filter cartridge
(item# CARBONLESSHICAPFILT)
___ ea. extra pre-filter cartridge
(item# SEDIMENTPREFILTER)

Standard carbon water filter kit (refer to form# 1058)
(item# CARBONSTDCAPSYSTEM)
___ ea. extra primary water filter cartridge
(item# CARBONSTDCAPFILT)
___ ea. extra pre-filter cartridge
(item# SEDIMENTPREFILTER)

SafeCLEAN Plus™ ice machine cleaner
(refer to form# 8295)

Nu-Calgon IMS-III sanitizer, 16 oz bottle
(item# 00979674)

Symphony Plus 414 ice machines			
Dispenser series	Condenser	Model number	Item number
Countertop and wall mount dispensers with ice machine behind splash panel 	air-cooled	25CI414A	P414A
		25HI414A	
		50CI414A	
	water-cooled	25CI414W	P414W
50CI414W			
Freestanding dispensers with ice machine in base 	air-cooled	25FB414A	P414A
		50FB414A	
		110FB414A	
	water-cooled	25FB414W	P414W
		50FB414W	
		110FB414W	

Specification

P414A and P414W

W2 Width	15.25" (38.7 cm)
D2 Depth	19.85" (50.4 cm)
H2 Overall height	16.83" (42.7 cm)
Electrical	7.2 amps
115 V/60/1	
Refrigerant	air-cooled models – R290, 3.49 oz (99 g) water-cooled models – R290, 1.83 oz (52 g)
Approximate net weight	109 lb (49 kg)
Approximate ship weight	130 lb (59 kg)

Dimensional drawing

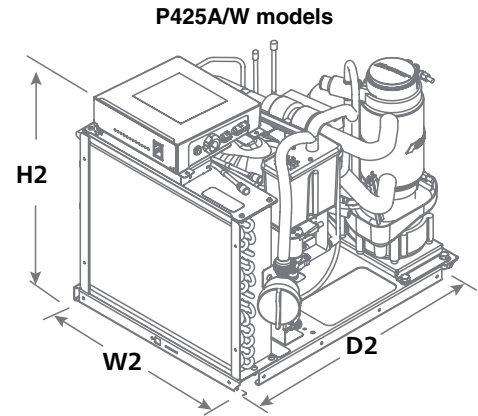

SYMPHONY PLUS and SAFECLEAN PLUS are trademarks of Follett Products, LLC.
CHEWBLET, FOLLETT and RIDE are registered trademarks of Follett Products, LLC, registered in the U.S.
Follett reserves the right to change specifications at any time without obligation. Certifications may vary depending on country of origin.