

PAN RACKS

STAINLESS STEEL PAN RACKS

KELMAX by
SPG



ITEM # _____ MODEL # _____ QTY: ____

PROJECT: _____

OPTIONS: YES _____ NO _____

Standard Features & Benefits

- ◆ Polished 16 gauge 304 Series Stainless Steel finish
- ◆ Standard unit holds both 18" x 26" and 14" x 18" sheet pans on 1 1/2" runners
- ◆ Nesting pan rack saves space
- ◆ Universal pan racks are multipurpose racks, designed to transport 18" x 26" and 12" x 20" pans
- ◆ All welded Stainless Steel body for extra durability
- ◆ All units have 5" polyurethane casters
- ◆ Custom sizes available
- ◆ Available in mill finish
- ◆ Rack covers available

Full-Size Model

Model No.	Tray Capacity	Spacing (in.)	D x L x H (in.) (mm.)		Weight (lbs.) (kg.)	
End Load						
4J0045	10	6	26 x 21 x 69	660 x 533 x 1753	80	37
4J0055	12	5	26 x 21 x 69	660 x 533 x 1753	82	37
4J0062	15	4	26 x 21 x 69	660 x 533 x 1753	85	39
4J0073	18	3	26 x 21 x 65	660 x 533 x 1651	88	40
4J0075	20	3	26 x 21 x 69	660 x 533 x 1753	91	41
4J0092	30	2	26 x 21 x 69	660 x 533 x 1753	110	50
Side Load						
4J0846	12	5	29 x 18 x 69	737 x 457 x 1753	87	40
4J0087	20	3	29 x 18 x 69	737 x 457 x 1753	110	50

For SPG's complete product menu, visit www.spgusa.com or call 877.503.4SPG (4774)

EXPECT MORE
SPG
STORAGE PRODUCTS GROUP

PAN RACKS

SPECIFICATIONS

Half-Size Model

Model No.	Tray Capacity	Spacing (in.)	D x L x H (in.) (mm.)		Weight (lbs.) (kg.)	
Open Top						
4J0499	10	3	26 x 21 x 38	660 x 533 x 965	48	22
4J0628	6	5	26 x 21 x 38	660 x 533 x 965	42	19
Stainless Steel Top						
4J0596	10	3	26 x 21 x 38	660 x 533 x 965	63	28
4J0587	6	5	26 x 21 x 38	660 x 533 x 965	57	26

Nesting Polished Stainless Steel Racks

Model No.	Tray Capacity	Spacing (in.)	D x L x H (in.) (mm.)		Weight (lbs.) (kg.)	
End Load						
4J0131	12	5	26 x 21 x 69	660 x 533 x 1753	82	37
4J0501	18	3	26 x 21 x 65	660 x 533 x 1651	88	39
4J0137	20	3	26 x 21 x 69	660 x 533 x 1753	89	40
Side Load						
4J0557	20	3	29 x 18 x 69	737 x 457 x 1753	110	50

Additional Models

Model No.	Tray Capacity	Spacing (in.)	D x L x H (in.) (mm.)		Weight (lbs.) (kg.)	
Universal Pan Racks						
4J0595	12	5	26 x 21 x 69	660 x 533 x 1753	82	37
4J0159	20	3	26 x 21 x 69	660 x 533 x 1753	91	41
For Roll-In Refrigerators 65" Clear						
4J0290	11	5	26 x 21 x 65	660 x 533 x 1651	80	36
4J0256	18	3	26 x 21 x 65	660 x 533 x 1651	88	40

Unit Options

Model No.	Description
/PC	5" Polyurethane Plate Casters
/BK	Locking Brakes
/VB	Vertical Corner Bumpers (4)
/SB	Solid Base
/TG	Stainless Tray Guards

To select an option, please contact factory for part number.

AMCO • Freestyle • ISS • Kelmax • LPI • Universal Stainless • Gillis-Jarke

SPG International, LLC
11230 Harland Drive NE
Covington, GA 30014
877-503-4SPG (4774)

www.spgusa.com

The best names in the business
all have one thing in common.

EXPECT MORE
SPG
STORAGE PRODUCTS GROUP

PAN RACKS

SPECIFICATIONS

CONSTRUCTION:

Constructed of all welded 16 gauge 304 series Polished Stainless Steel.

UPRIGHTS & CROSS-BRACES:

Sides/Uprights consist of 1" square stainless steel tubing (16 gauge) continuously welded.

RUNNERS:

All runners are fully welded to the uprights. Runners are 1" x 1 1/2", 16 gauge.

RUNNERS (UNIVERSAL):

All runners are fully welded to the uprights. Runners are 1" x 1 1/2", 16 gauge.

CASTERS:

Units feature a standard polyurethane 5" x 1 1/2" wheel on a swivel stem caster.

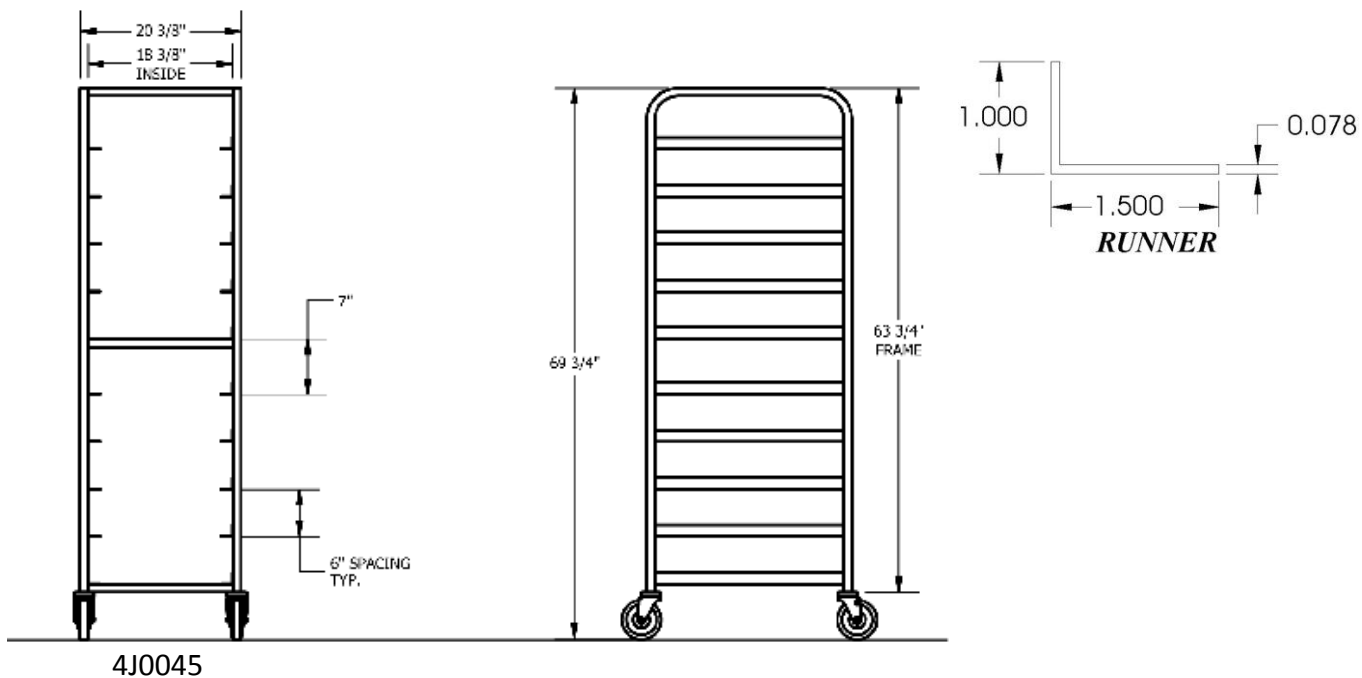

AMCO • Freestyle • ISS • Kelmax • LPI • Universal Stainless • Gillis-Jarke

SPG International, LLC
11230 Harland Drive NE
Covington, GA 30014
877-503-4SPG (4774)

www.spgusa.com

The best names in the business
all have one thing in common.

EXPECT MORE
SPG
STORAGE PRODUCTS GROUP