

Fusion

GLDS 52"H Refrigerated Service Case Self-Contained

Structural Concepts®

DELIVERING FRESH. ALWAYS.™

- **GLDS4R** 51"L x 47-7/8"D x 51-5/8"H
- **GLDS5R** 62-7/8"L x 47-7/8"D x 51-5/8"H
- **GLDS6R** 75-3/8"L x 47-7/8"D x 51-5/8"H

Included

- Breeze self-contained refrigeration
- LED top light
- Lift-up front glass
- One year parts & labor; 5 year compressor warranty
- Stainless steel rear exterior
- Warmest average product temperature of 40°F or less



GLDS6R

Specify	Standard Features	Additional Options
EXTERIOR COLOR	• Laminate (stock colors)	• Laminate (non-stock colors) • Powder coated (stock/non-stock colors) • Powder coated Silversan Black • Stainless steel
INTERIOR COLOR	• Powder coated Silversan Black	• Stainless steel
LOWER FRONT PANEL COLOR	• Powder coated Silversan Black	• Powder coated (stock/non-stock colors) • Stainless steel
BASE SUPPORT	• Casters w/ levelers (self-cont.)	• 6"H legs (self-cont.)
BUMPER FRONT	• 1" Boston bumper (specify color)	• 1" Stainless steel plate rail bumper
DISPLAY	• None	• 2"H Full depth display riser(s)
END PANELS	• Full w/stainless steel mirror interior	• Cutaway w/glass • None (specify per line-up)
FRONT GLASS	• Curved	• Flat angled
REAR LEDGE	• Black Sanalite®	• Stainless steel
SCALE STAND	• None	• Scale stand w/ receptacle & CAT5 (specify location) • Scale stand w/ receptacle (specify location)
PRICE TAG MOLDING	• None	• 1" Price tag molding (black or silver) • Universal price tag molding (clear w/ open top)
LIGHTS	• LED 3500K w/ frosted lens	• LED 4000K w/ frosted lens
ELECTRICAL CONNECTION	• 6' Straight blade power cord (self-cont.)	• 6' Locking power cord (self-cont.)
REFRIGERATION	• Breeze self-contained refrigeration	
MISCELLANEOUS		• Front glass lock • Rear door lock
ACCESSORIES		• Clean Sweep® coil cleaner (self-cont.) • Drain strainer • Stainless steel condiment rail system

Option Notes: 1 - Separate circuit required

Intended Environment: Type I - Designed to operate in ambient conditions of 75°F with 55% relative humidity unless noted otherwise in system information below.		
Zone	Intended Product To Be Displayed	Warmest Avg Prod Temp ° F
1	Unpackaged refrigerated products-Prechilled to Warmest Avg Prod Temp.	40

PLAN VIEW

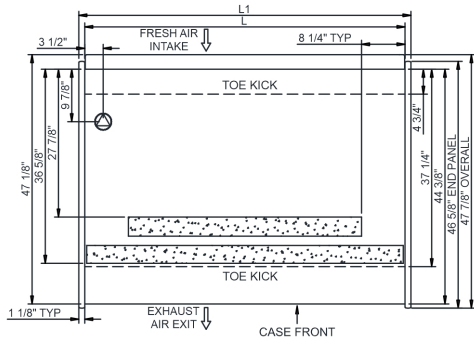

SIDE VIEW

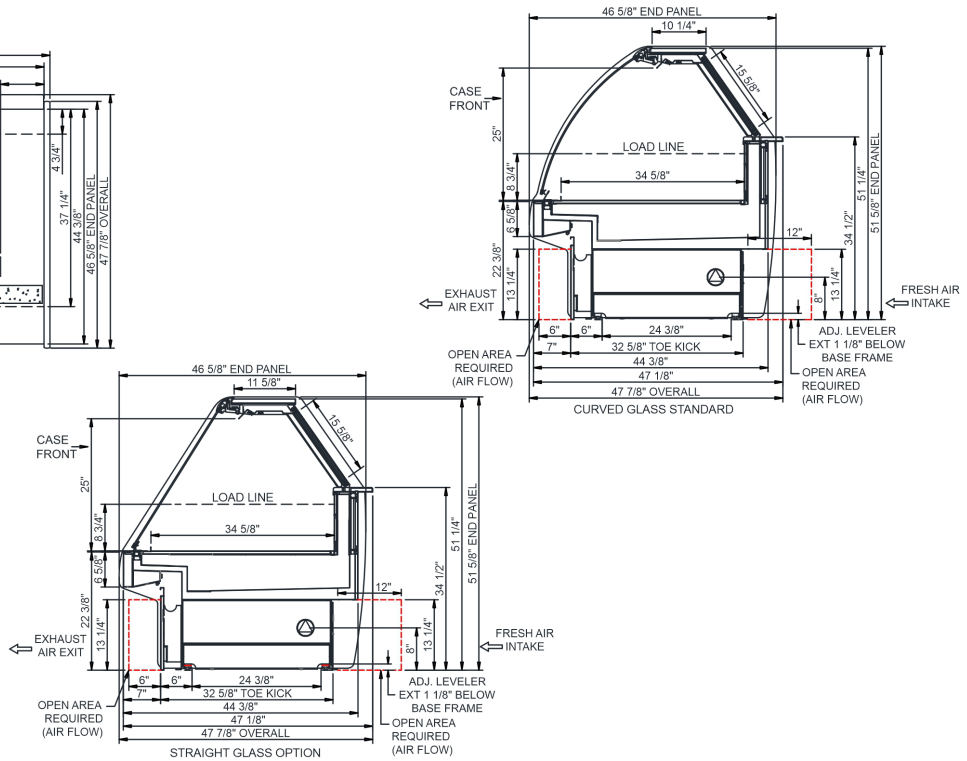

NOTE: ALL DIMENSIONS APPROXIMATE

- ELECTRICAL JUNCTION BOX**
(SUPPLIED WITH 6" LEADS OR POWER CORD).
- REFRIGERATION LINE CONNECTION.**
- SELF-CONTAINED CASE SERVICE ACCESS AREA.**
- LOCATION OF DRAIN TUBE FOR REMOTE REF. ONLY** (SUPPLIED WITH 3/4" OR 1 1/2" PVC TUBE).
- REMOTE FLOOR SINK & UTILITIES ACCESS AREA.**
- DRY CASE SERVICE ACCESS AREA.**

Model Technical Specifications

Model	L"	L1"	L2"	System Circuit Volts		Phs	Freq	Amps ***	Watts	Wires	NEMA Plug	SST	Conv. Rack BTUH	Para. Rack BTUH	Est Wt	
				Circuit #1	110-120											
GLDS4R	48.75	51.00	3.50	Self-Contained (R290)	Circuit #1	110-120	1	60	14.61	1,479	2+G	5-20P or L5-20P	N/A	N/A	N/A	1,050
GLDS5R	60.63	62.88	3.50	Self-Contained (R290)	Circuit #1	110-120	1	60	15.06	1,513	2+G	5-20P or L5-20P	N/A	N/A	N/A	1,150
GLDS6R	73.13	75.38	3.50	Self-Contained (R290)	Circuit #1	110-120	1	60	15.06	1,519	2+G	5-20P or L5-20P	N/A	N/A	N/A	1,250

*** Does not include electric defrost on freezer models.

Regulatory Approvals:

All Models
 Accordance with AHRI Std 1200
 ETL Listed to UL 471
 ETL Listed to CAN/CSA 22.2 No. 120
 ETL Sanitation to NSF/ANSI 7



In Accordance with
AHRI Std 1200

DOE 2017
Energy Efficiency
Compliant

Important Notes:

- 1) ELECTRICAL NOTE: If GFCI is required, a GFCI breaker MUST be used in lieu of a GFCI receptacle.
- 2) 50" minimum door entry clearance required (without shipping skid).
- 3) Units must be shimmed during installation to ensure the unit is level and plumb.

⚠ WARNING: This product can expose you to chemicals, including Urethane (Ethyl Carbamate), which are known to the State of California to cause cancer and birth defects or other reproductive harm. For more information go to www.P65Warnings.ca.gov.