

# SANDWICH UNIT REFRIGERATOR

## Model: SW60N8-D

Natural Refrigerant R-290 Model

### 60" Standard Top Sandwich Unit Refrigerator with Drawers - 8 Pans

Stainless steel front, top and end panels, aluminum back and interior.



## Options and Accessories

(upcharge and lead times may apply)

Stainless steel interior	Drawer locks
Stainless steel back	Front breathing
Overshelves (single or double)	Rear mounted cutting board
Adjustable legs	Composite cutting board
Optional caster sizes	Crumb catcher
Flat lid	Modified pan opening
Vision panel lid	

Consult factory for other model configurations, options and accessories.

**Continental**  
Refrigerator



Project Name:

Model Specified:

Location:

Item No:

Quantity:

AIA #:

SIS #:

## Standard Model Features

### REFRIGERATION SYSTEM

Performance rated refrigeration system

Natural, environmentally safe, high efficiency R-290 refrigerant<sup>1</sup>

Unique air flow distribution allows pan product to maintain 33° - 41°F

Automatic, hot gas condensate evaporator

Non-corrosive, plasticized fin evaporator coil

Easily serviceable, back mounted compressor

Expansion valve system

### CABINET ARCHITECTURE

2" non-CFC polyurethane foam insulation

Smooth, polished chrome drawer handles

Stainless steel roll out drawers

Magnetic snap in Santoprene™ drawer gaskets

12" deep, full length nylon cutting board

Insulated lid

Completely enclosed, vented and removable case back

5" casters

### MODEL FEATURES

Electronic control, off-cycle defrost

(8) 1/6 size recessed pans, 4" deep

Removable interior tub below pans

<sup>1</sup> R-290 refrigerant meets all federal and state regulatory requirements.

APPROVAL:

# Model Specifications

## DIMENSIONAL DATA

Net Capacity (cubic feet)	17.0 (481 l)
1/6 Size Pans (4" deep)	8
Width, Overall (inches)	60 (1524 mm)
Depth, Overall (inches) (including handles & bumpers)	32 3/16 (818 mm)
Depth, Cutting Board (inches)	12 (305 mm)
Height, Overall (inches) (including 5" casters)	42 1/4 (1073 mm)
Number of Drawers	4

## REFRIGERANT DATA

Condensing Unit Size (H.P.)	1/3
R-290 Refrigerant Charge (oz)	5.2
Capacity (BTU per hour)*	2540

\* Rating @ +25°F evaporator, 90°F ambient

## ELECTRICAL DATA

Voltage (International)	115/60/1 (220/50/1)
Total Amps (International)	5.2 (2.6)
10 ft. Cord/Plug [attached] (International)	Yes (No)

## SHIPPING DATA

Weight (pounds)	455 (207 kg)
Height - Crated (inches)	43 1/4 (1099 mm)
Width - Crated (inches)	68 (1727 mm)
Depth - Crated (inches)	37 1/4 (946 mm)

## DRAWER PAN CONFIGURATIONS

**Two Tier:** (1) 12 x 20 x 6 pan per drawer

Figures in parentheses reflect metric equivalents rounded to the nearest whole unit.



Equipped with one NEMA-5-15P Plug  
(varies by country)

# Continental<sup>®</sup>

Refrigerator

Toll-Free: 800-523-7138  
Phone: 215-244-1400  
Fax: 215-244-9579

539 Dunkserry Road  
Bensalem, PA 19020  
[www.continentalrefrigerator.com](http://www.continentalrefrigerator.com)

Due to our continued efforts in developing innovative products, specifications subject to change without notice.



PROUDLY  
DESIGNED & ASSEMBLED  
IN THE U.S.A.

© Copyright 2021. Continental Refrigerator.  
A Division of National Refrigeration & Air Conditioning Products, Inc.

# Model Plan Views

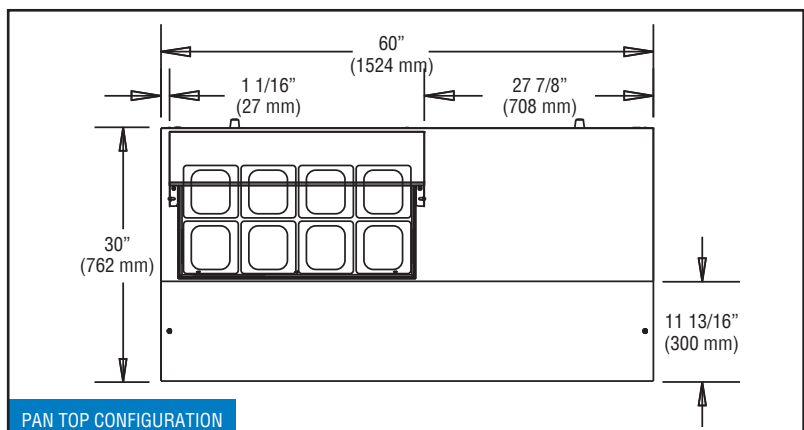
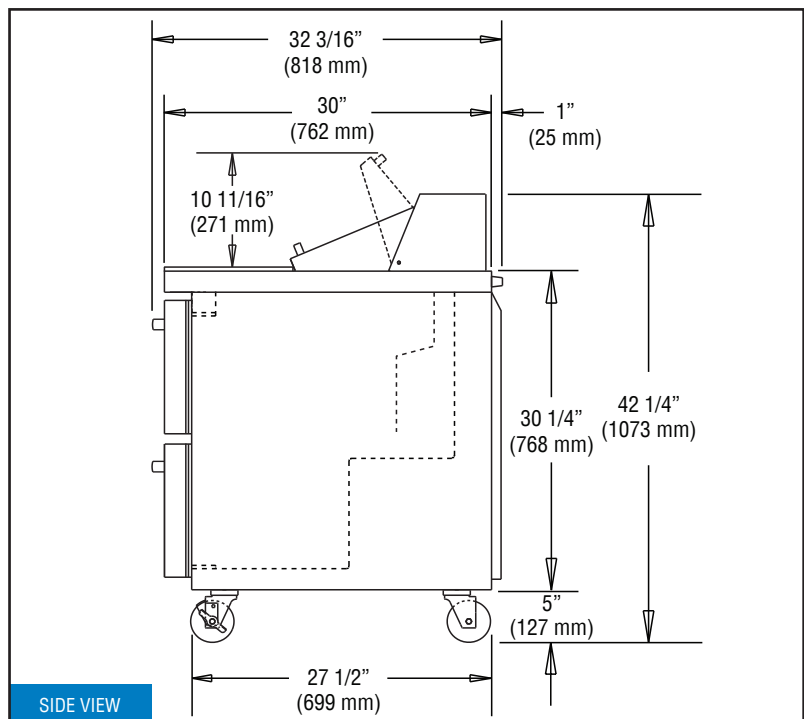
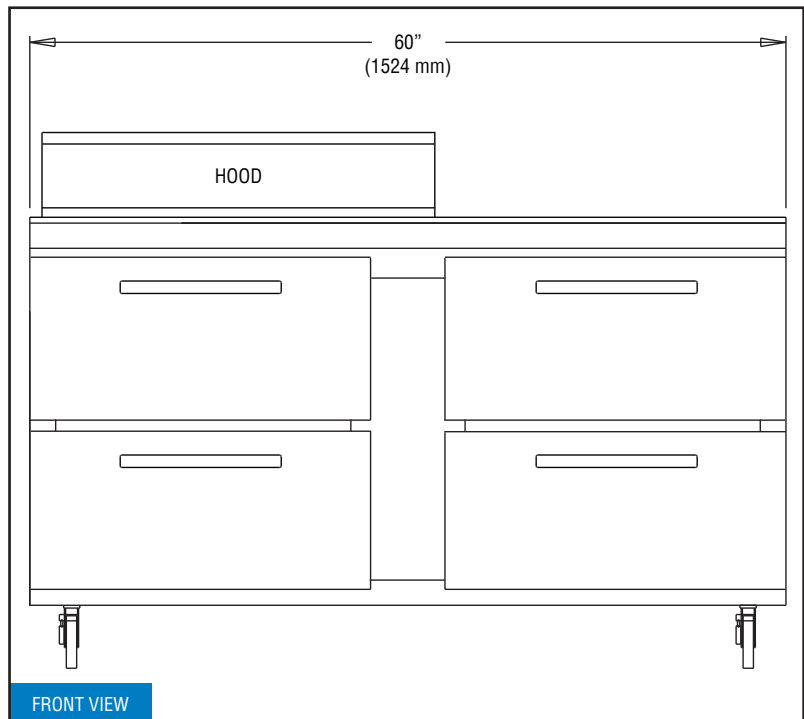

REVISED: 12/4/25