



C-FBSA-12



Intertek
4004503
Conforms to ANSI/NSF STD 2

Specifications

Legs

- 1-5/8" diameter, 16 gauge stainless steel
- Stainless steel bullet feet

Materials

- 20 gauge stainless steel

Project: _____	AIA# _____
Item #: _____ Qty: _____	SIS# _____
Model #: _____	

Filler Board Blender Stations

C-FBS	C-FBSA-12, C-FBSA-14, C-FBSA-18, C-FBSB-12, C-FBSB-14, C-FBSB-18
--------------	---

Standard Features

- All stainless steel construction
- One-piece seamless top and backsplash
- Adjustable stainless steel bullet feet
- Filler board work surface
- Blender shelf features radius interior corners for easy cleaning
- Power cord access hole with grommet located on front skirt, behind the blender
- Junction box for duplex GFI outlet mounted underneath blender shelf (outlet not included)

NOTE: Blender stations cannot have a speed rail mounted to them. Since speed rails are so common on underbar, blender stations come in 24" and 29" depths to align with underbar that has a speed rail.

Configurable Options

C-LS15-F	Left side splash for C-FBSA models
C-RS15-F	Right side splash for C-FBSA models
C-LSA-F	Left side splash for C-FBSB models
C-RSA-F	Right side splash for C-FBSB models

Accessories

TR	Towel Ring
----	------------

Underbar installation instructions: <https://www.glastender.com/support/documents/manuals/underbar-installation-instructions>

Cleaning & care instructions: <https://www.glastender.com/support/documents/manuals/general-cleaning-and-care-instructions-for-stainless-steel>

Glastender, Inc. • 5400 North Michigan Road • Saginaw, MI • 48604-9780
989.752.4275 • 800.748.0423 • Fax 989.752.4444
<https://glastender.com>

Approval/Notes:

Specifications subject to change without notice. For current specifications please visit our website.

Choice Filler Board Blender Stations

Dimensional Information

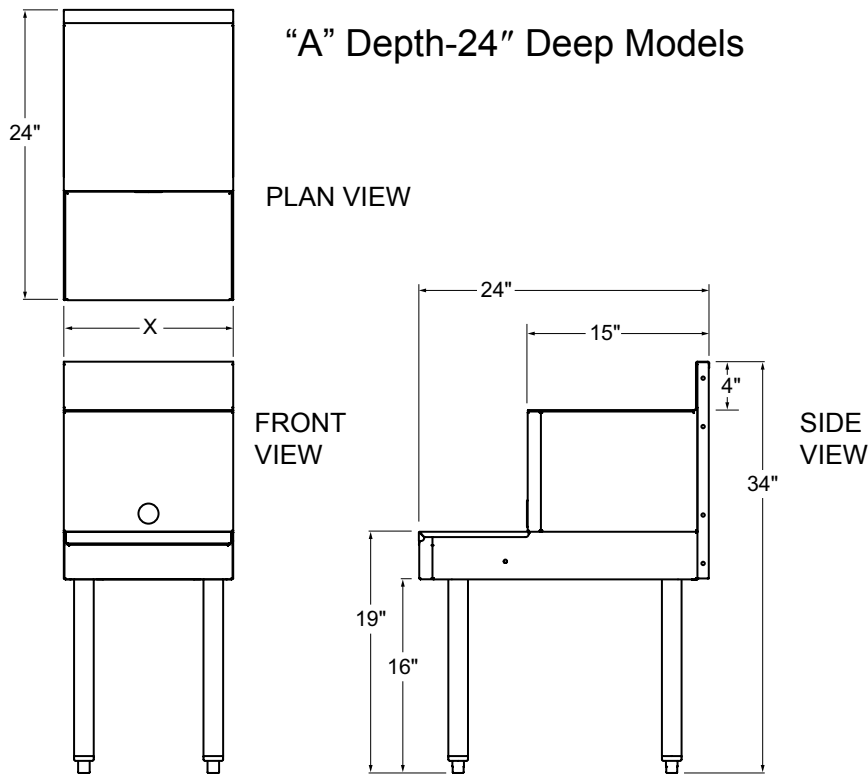

Model Number	X
C-FBSA-12	12"
C-FBSA-14	14"
C-FBSA-18	18"

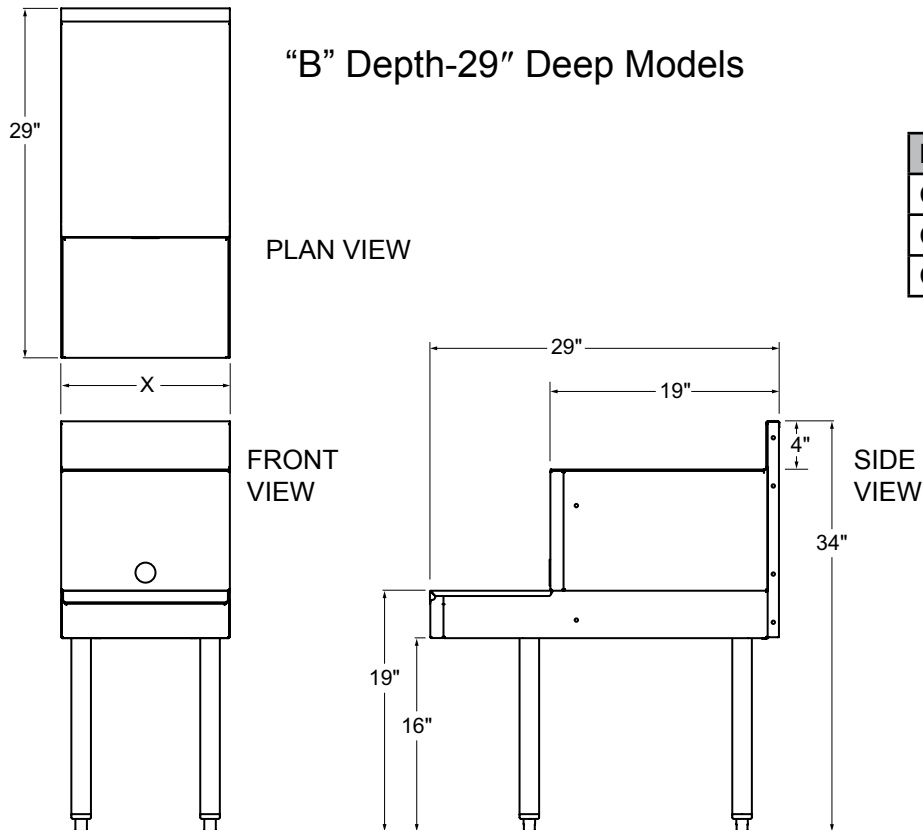

Model Number	X
C-FBSB-12	12"
C-FBSB-14	14"
C-FBSB-18	18"