

SIDE MOUNT UNDERCOUNTER DUAL TEMP SIDE MOUNTED CONDENSING UNIT



ETRF2

ET Series



Refrigeration System

- Side mounted, self-contained condensing unit uses environmentally friendly, EPA-compliant R290 refrigerant with zero (0) Ozone Depletion Potential (ODP) and three (3) Global Warming Potential (GWP).
- Electronically commutated (ECM) fan motors achieve rapid cooling with less energy consumption.
- Time-initiated and temperature-terminated auto defrost heater for freezers. Air defrost for refrigerators.
- Large capacity, corrosion-resistant condenser and evaporator coils.
- Self-maintaining, energy-efficient condensate drain pan requires no external drains or electric heaters.
- High performance, auto-reverse condenser fan motor supports compressor ventilation and condenser coil cleaning.
- Pressure relief devices allow rapid cabinet re-entry.
- Pre-wired and ready to plug, 115V/60Hz/1Ph, NEMA 5-15P.

Cabinet Construction

- Heavy duty stainless steel interior / exterior with rounded corners for a hazard-free workspace.
- Insulated interior wall between refrigerator and freezer compartments.
- 16 gauge, high quality stainless steel worktop.
- Galvanized steel bottom and rear.
- 2.5" thick high density polyurethane insulation.
- Four 5" swivel casters with locks on front set.

Lighting

- Energy efficient silicone coated and shatter-proof LED lighting provides bright, high color illumination with low heat output.

Doors

- Heavy duty stainless steel interior / exterior.
- 2.5" thick high density polyurethane insulation.
- Frame heaters prevent exterior moisture build up.
- Self-closing with adjustable torsion system for a positive seal.
- Snap-in magnetic door gasket make cleaning and replacement an easy process.
- High strength, recessed door handles.
- Pre-installed door locks keep your items safe from theft.

Shelving

- Two epoxy coated, steel wire shelves per section.
- Height adjustable stainless steel clips.

Temperature Control

- Multi-function digital controller with easy to read LED display.
- Factory preset temperature, 35°F for refrigerators and -4°F for freezers. Temperature setting range from 33°F to 54°F for refrigerators and -10°F to 54°F for freezers.
- R290 models include audible overheat protection alarm for compressor and condenser coil.

Options

- 4" high stainless steel backsplash for worktop application.
- Additional shelving.
- 3" swivel casters with locks.
- 3.5" – 6" height-adjustable and interchangeable legs.
- NSF Certified Stainless Steel Double Overshelf.



Type	Doors	Capacity Cu. Ft.	# of Pans (Top)	# of Pans (Drawer)	Shelves	Refrigerant	HP	Power V-Hz-Ph	Amps	Crated Weight	Exterior Dimensions		
											L	D	H*
DUAL	2	9(R) 9(F)	-	-	4	R-290	1/2	115-60-1	7.54	316 lbs	59.25"	31.5"	29.25"

(†)Based on evaporating temperature of 23°F (-5°C) & condensing temperature of 131°F (55°C). (P) Product capacity is calculated based on standard industry figures. (*) Reference plan view for clarification on caster/unit height. If dimensions and capacity are critical, please contact Everest Refrigeration. Blizzard R290 replacement is at the sole discretion of Everest Refrigeration. Specifications subject to change without notice.

SIDE MOUNT UNDERCOUNTER DUAL TEMP SIDE MOUNTED CONDENSING UNIT



ETRF2

ET Series

DIMENSIONAL DATA

External Dims.	L	59.25 in.
	D	31.5 in.
	H*	29.25 in.
Crated Weight		316 lbs.
Doors/Drawers/Lids		2
Max Weight Support		-

STORAGE DATA

Net Capacity Cu. Ft. †	9(R) 9(F)
Shelves	4
Barrels	-
20 oz. Bottles	-
12 oz. Bottles	-
12 oz. Cans	-
8" Mugs	-
# of Pans (Top)	-
# of Pans (Drawer)	-
Dividers	-
Trays	-

ELECTRICAL DATA

Voltage	115-60-1
Full Load Amperage	7.54A
Feed Wires w/ Ground	3
Cord Length	9ft
NEMA Plug Type	NEMA 5-15P

REFRIGERATION DATA

Compressor	Side
Refrigerant	R-290
Compressor HP	1/2
BTU/HR †	3435

KEY

D	Door	R	Refrigerator
L	Lid	REF	Refrigerator
H	Half Door	F	Freezer
FD	Full Door	FRZ	Freezer
SD	Solid Door	DUAL	REF/FRZ Combo
GD	Glass Door	DR	Drawer

	Elevation	Right	Plan	3D	Back

PLAN VIEW

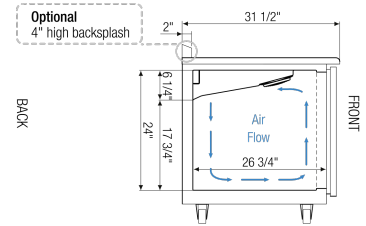
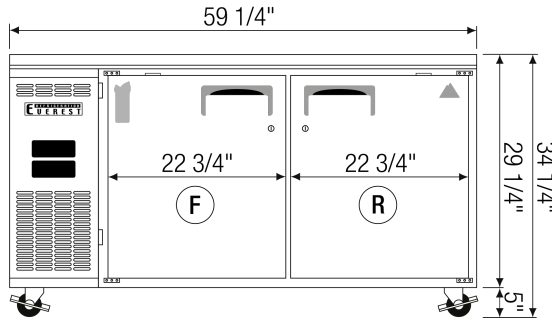

FRONT

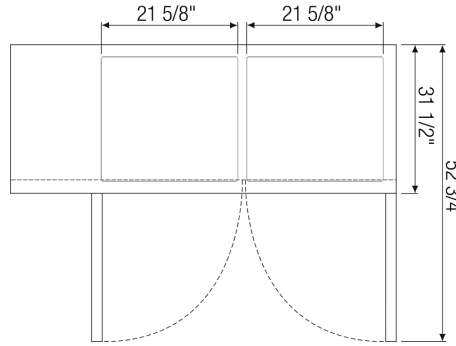

TOP

ACCESSORIES & OPTIONS

- Additional Shelving - Contact Everest Refrigeration for more information.
- AJL03-00 - Interchangeable Leg for Caster (Optional)
- BKSP03-00 - 4" High (59-1/2" Long) Stainless Steel Backsplash
- CASA3-01 - 3" Overall Height Caster Assembly - (2) Front (2) Rear
- OS27-00 - Double overshelf (57" L x 13.5" D x 46" H*) for side mount

(†)Based on evaporating temperature of 23°F (-5°C) & condensing temperature of 131°F (55°C). (‡) Product capacity is calculated based on standard industry figures. (*) Reference plan view for clarification on caster/unit height. If dimensions and capacity are critical, please contact Everest Refrigeration. Blizzard R290 replacement is at the sole discretion of Everest Refrigeration. Specifications subject to change without notice.