



Project _____
 AIA # _____ SIS # _____
 Item # _____ Quantity _____ C.S.I. Section 114000

R Series

Roll-In Freezer for 66" High Racks
 32" Deep, Self-Contained



STANDARD PRODUCT FEATURES

- Stainless Steel Exterior & Interior
- Traulsen's Smart Control™ with LED Display
- StayClear™ Condenser Coil
- Balanced, Self-Contained Refrigeration System Using R-290
- Rear Biased Return Air Duct
- Full-Height Stainless Steel Doors with Locks
- Self-Closing Doors with Stay Open Feature
- Standard Door Hinging: 332L = Left/Right/Right (other hings available)
- Automatically Activated LED Lights
- Stainless Steel Breaker Caps
- Accommodates Roll-In Racks Up to 66" High (provided by others)
- Automatic Non-Electric Condensate Evaporator
- Magnetic Snap-In EZ-Clean™ Door Gaskets
- Thermostatic Expansion Valve Metering Device
- Stainless Steel One-Piece Louver Assembly
- Stainless Steel Interior Rack Guides & Threshold Ramps
- 9' Cord & Plug Attached

ACCESSORIES & OPTIONS

- SmartConnect™ Monitoring App with Wi-Fi Connectivity
- Stainless Steel Finished Back with Rear Louvers
- Coated Wire Shelf Package (includes 3 shelves per section)
- Additional Coated Wire Shelves for Above
- Rehinge Feature (consult factory)
- Stainless Steel Banking Strip
- Stainless Steel Shelf Package (includes 3 shelves per section)
- Additional Stainless Steel Shelves for Above
- Locking Hasps (padlocks supplied by others)
- Kool Klad™ Exterior Laminate Decor
- Heat Shield
- Transition Strip for Recessed Floor Installation
- Prison/Correctional Facility Options



Models listed to the applicable UL, CSA and NSF standards by an approved NRTL. Consult the factory or unit data plate for additional information.

AVAILABLE CONFIGURATIONS

R Series Model
 RIF332LUT-FHS

Doors
 Full Height Solid

***Remote application available,
 see form TR35837 for details.**

- **GUARANTEED FOR LIFE CAM-LIFT HINGES**
- **GUARANTEED FOR LIFE HORIZONTAL WORKFLOW DOOR HANDLES**

Approved by _____ Date _____ Approved by _____ Date _____



R Series

Roll-In Freezer for 66" High Racks
32" Deep, Self-Contained

MODEL:

RIF332LUT-FHS

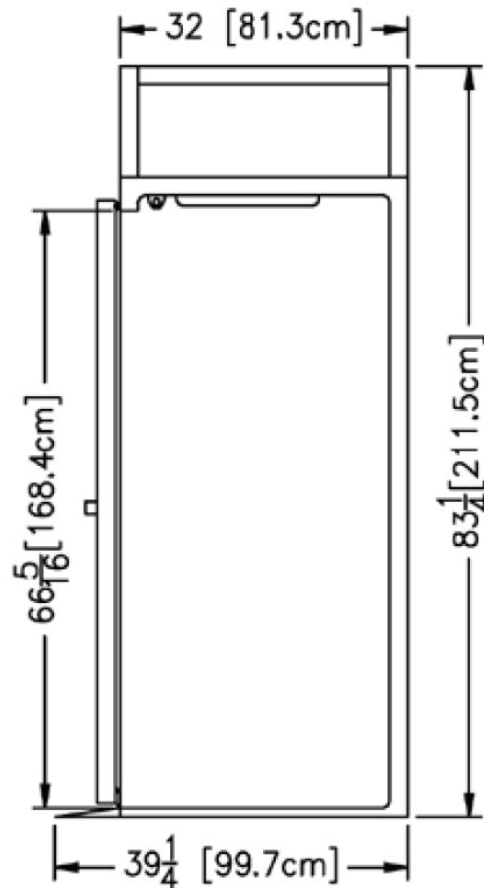
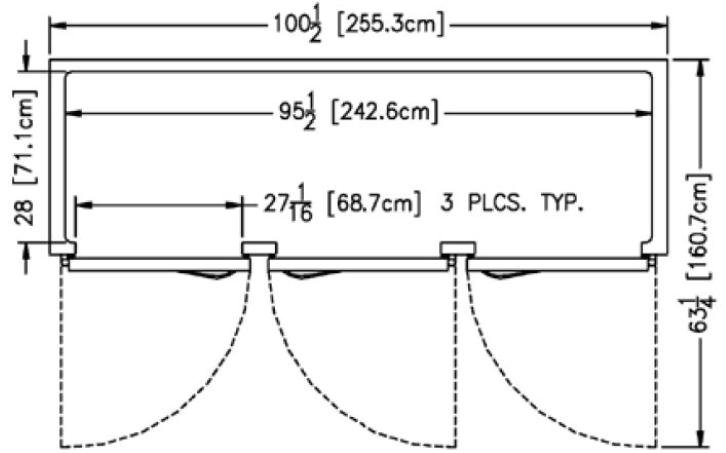
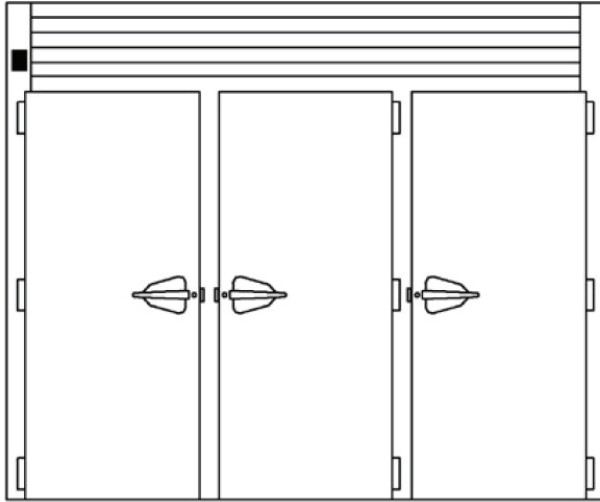

CAD and/or Revit Files Available

<https://traulsen.klccad.com/>



MODEL:

RIF332LUT-FHS

MODEL	RIF332LUT-FHS
DIMENSIONAL DATA	
Net capacity cu. ft.	111.49 (3157.05 cu l)
Length - overall in.	100 1/2" (255.3 cm)
Depth - overall in.	39 1/4" (99.7 cm)
Depth - over body in.	32" (81.3 cm)
Depth - door open 90° in.	63 1/4" (160.7 cm)
Clear door width in.	27 1/16" (68.7 cm)
Clear door height in.	66 5/16" (168.4 cm)
Height - overall in. ²	83 1/4" (211.5 cm)
Capacity - 66" High	3
ELECTRICAL DATA	
Voltage Plug	208-230/115/60/1 NEMA 5-20P
Full Load Amperes kWh/24HR ³	17 24.61
REFRIGERATION DATA	
Refrigerant	R-290
Refrigerant Charge Amount oz.	4.5 (127.57 g)
BTU/HR H.P. ¹	3100 1-1/4
SHIPPING DATA	
Length - Crated in.	105" (266.7 cm)
Width - Crated in.	42" (106.7 cm)
Height - Crated in.	94" (238.8 cm)
Volume - Crated cu. ft.	240 (6796.04 cu l)
Weight - Crated lbs.	1380 (626 kg)

NOTES: Figures in parentheses reflect metric equivalents.

1. Based on a 90°F ambient and -20°F evaporator.
2. 12" Top clearance preferred for optimum performance & service access.
3. kWh/24HR = Kilowatt usage per 24 hours.

EQUIPMENT SPECIFICATIONS

CONSTRUCTION, HARDWARE, INSULATION

The interior is made from stainless steel and the cabinet exterior front, one piece sides, louver assembly, door and door liner is constructed of heavy gauge stainless steel. The exterior cabinet top, back & bottom are constructed of heavy gauge galvanized steel. The interior floor is constructed of stainless steel & insulated with 3/4" of resilient cork. A readily attachable stainless steel ramp is provided to facilitate loading/unloading.

Doors are equipped with heavy-duty, extruded wiper gasket for sealing to bottom ramp, removable plug cylinder locks & guaranteed for life gravity action, self-closing metal, cam-lift hinges with a stay open feature. Hinges include a concealed switch to automatically activate the interior LED lighting. Guaranteed for life, workflow door handles are mounted horizontally over recess in door which limits protrusion from door face into aisleways. Door has seamless, polished metal corners.

Gasket profile & EZ-Clean™ material simplify cleaning & increase overall gasket life. Both the cabinet & door are insulated with an average of 2" thick high density, non-CFC, foamed in place polyurethane.

SELF-CONTAINED REFRIGERATION SYSTEM

A top mounted, self-contained, balanced refrigeration system using environmentally friendly, low GWP R-290 refrigerant is conveniently located behind the one piece louver assembly. It features a finless StayClear™ condenser, thermostatic expansion valve, air-cooled hermetic compressor, large, high humidity evaporator coil located outside the food zone & top mounted non-electric condensate evaporator. Rear biased return air duct protects against introduction of warm kitchen air, promoting even temperature maintenance & efficient operation. A 9' cord & plug is provided. Standard operating temperature is 0 to -5°F (all models are -10°F capable in up to 100°F ambient).

CONTROL

Traulsen's Smart Control™ features advanced control algorithms & sophisticated diagnostic capabilities to optimize performance. Utilizing smart sensors, it adapts the operation of the refrigeration system to a variety of environments & usage patterns. The Smart Control™ also offers a complete set of visual alarms designed to alert the user to critical events such as power outages or a prolonged door opening. In the event of an alarm, a dedicated Alarm LED will illuminate, informing the user of the critical event and duration.

INTERIOR

Readily removable, interior-mounted, stainless steel guides for racks are provided for protection. Maximum rack size with wheels inboard of frame is 27" wide by 29" deep by 66" high. Racks are supplied by others.

WARRANTY

Both a six year parts and labor warranty and a seven year compressor warranty (self-contained models only) are provided standard.

When ordering please specify: Voltage, Hinging, and Options.

Equipped with one NEMA 5-20P Plug

