

DISPLAY FREEZER (0°F)

Model: 1FXSNGD

Natural Refrigerant R-290 Model

1-Section Extra-Wide Display Reach-In Freezer with Hinged Glass Door - Shallow Depth

1FXSNGD - Stainless steel front, aluminum end panels and interior

1FXSNSAGD - Stainless steel exterior, aluminum interior

1FXSNSSGD - Stainless steel exterior and interior



Options and Accessories

(upcharge and lead times may apply)

Stainless steel case back	Special electrical requirements (consult factory)
Additional epoxy coated steel shelves	Half doors
Chrome or stainless steel shelves	Rehinging of doors (consult factory)
Wine rack	Adjustable legs

Consult factory for other model configurations, options and accessories.

Continental
Refrigerator



Project Name:

Model Specified:

Location:

Item No:

Quantity:

AIA #:

SIS #:

Standard Model Features

REFRIGERATION SYSTEM

Self contained, performance rated refrigeration system

Natural, environmentally safe, high efficiency R-290 refrigerant¹

Automatic, electric condensate evaporator

Expansion valve system

Standard operating temperature is 0 to -5°F and can be adjusted to operate as low as -10°F in a 90°F ambient.

CABINET ARCHITECTURE

3" non-CFC polyurethane foam insulation

Triple-pane, tempered hinged glass door

Chrome plated door handle

Cam action, lift-off hinges

Self-closing door

Magnetic snap in door gasket

Cylinder lock in door

Heavy duty, epoxy coated steel shelves

5" casters

MODEL FEATURES

LED interior lighting

Electronic control, automatic electric defrost

¹ R-290 refrigerant meets all federal and state regulatory requirements.

APPROVAL:

Model Specifications

DIMENSIONAL DATA

Net Capacity (cubic feet)	26 (736 l)
Width, Overall (inches)	36 1/4 (921 mm)
Depth, Overall (inches) (including handle)	29 1/4 (743 mm)
Depth (inches) (less door)	25 7/8 (657 mm)
Depth (inches) (door open 90°)	60 3/4 (1543 mm)
Clear Door Width (inches)	29 5/8 (752 mm)
Clear Door Height (inches)	58 5/8 (1489 mm)
Height, Overall (inches) (including 5" casters)	82 1/4 (2089 mm)
Number of Doors	1
Number of Shelves	4
Shelf Area (square feet)	24.4 (2.3 sq m)

REFRIGERANT DATA

Condensing Unit Size (H.P.)	1/2
R-290 Refrigerant Charge (oz)	4.3
Capacity (BTU per hour)*	1980

ELECTRICAL DATA

Voltage (International)	115/60/1 (220/50/1)
Feed Wires (including ground)	3
Total Amps (International)	7.0 (3.5)
Defrost Amps (International)	6.1 (3.0)
10 ft. Cord/Plug [attached] (International)	Yes (No)

SHIPPING DATA

Height - Crated (inches)	85 1/2 (2172 mm)
Width - Crated (inches)	42 (1067 mm)
Depth - Crated (inches)	42 (1067 mm)
Volume - Crated (cubic feet)	87 (2464 cu l)
Weight Std - Crated (pounds)	400 (181 kg)
Weight SS - Crated (pounds)	480 (217 kg)

* Rating @ -15°F evaporator, 90°F ambient

Figures in parentheses reflect metric equivalents rounded to the nearest whole unit.

Model Plan Views

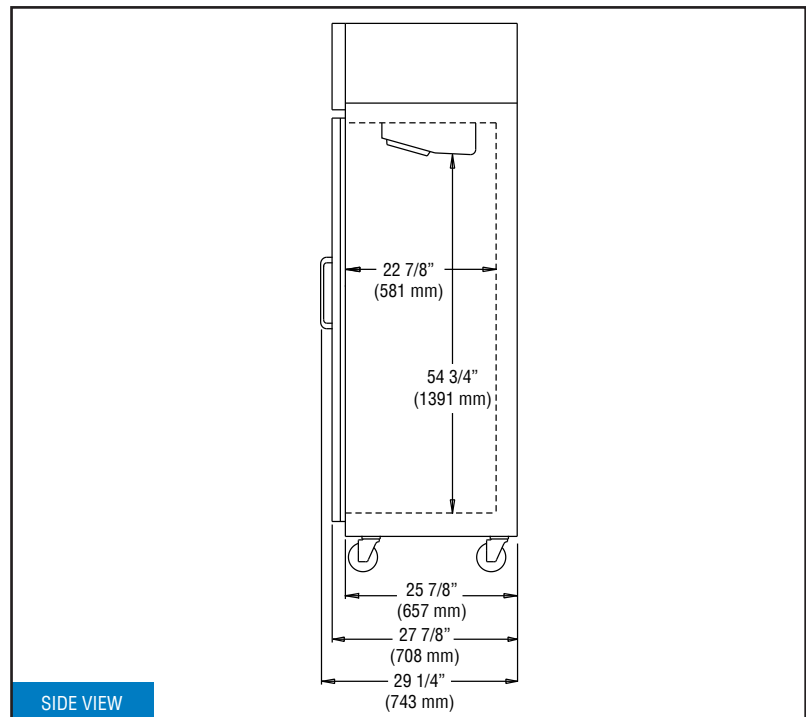
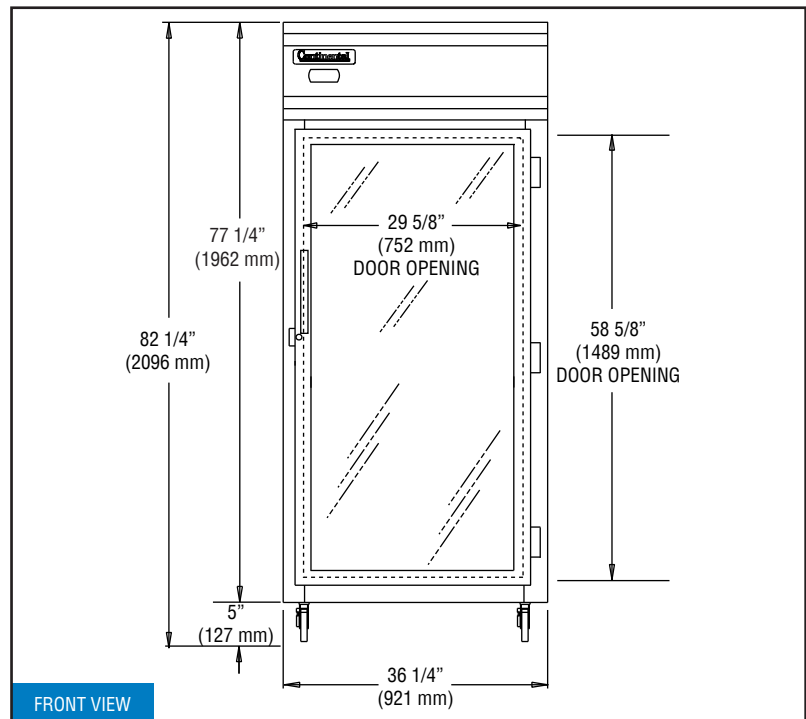

Continental
Refrigerator

Toll-Free: 800-523-7138
Phone: 215-244-1400
Fax: 215-244-9579

539 Dunksferry Road
Bensalem, PA 19020
www.continentalrefrigerator.com

Due to our continued efforts in developing innovative products, specifications subject to change without notice.



PROUDLY
DESIGNED & ASSEMBLED
IN THE U.S.A.

Intertek

© Copyright 2021. Continental Refrigerator.
A Division of National Refrigeration & Air Conditioning Products, Inc.

IMPORTANT NOTE: If the cabinet is located directly against a wall and/or under a low ceiling, a minimum clearance of 12" is required on top and 3" on sides and rear.



Equipped with one NEMA-5-15P Plug
(varies by country)

REVISED: 1/5/26