

36" Electric Range with Standard Oven Base

MODEL:

R36S-M* SERIES
**M denotes Marine option*



Model R36S-ATAM

MARINE SHORT/BID SPECIFICATION

Range shall be a LANG Manufacturing Marine Model R36S-____[Specify one]:

- -ATAM, with 1 ea. 24" X 24" X 1/2" thick Griddle and 2 ea. 8" diameter French Plates;
 - -ATBM, with 3 ea. 12" X 24" X 3/4" thick Hot Tops;
 - -ATCM, with 2 ea. 12" X 24" X 3/4" thick Hot tops and 2 ea. 8" diameter French Plates;
 - -ATDM, with 36" X 24" X 1/2" thick Griddle;
 - -ATEM, with 6 ea. 8" diameter French Plates
 - -ATFM, with 1 ea. 12" Hot top and 4 ea. 8" diameter French plates
- ... a 36" wide heavy duty electric heated unit with standard oven base and 21-kW total power input; hatchable two piece construction with all stainless steel exterior; fully insulated oven with aluminized steel interior, heavy duty spring assisted drop-down door with latch and one oven rack standard; individual oven and cook-top component controls; Sea rails and stainless steel front grab bar.

MARINE PRODUCT WARRANTY

Two year, parts & labor [Labor in U.S. only]



MARINE CONSTRUCTION FEATURES

- Two piece modular construction
- Heavy duty 430 Series stainless steel exterior, with attractive No. 4 finish
- 12" high cooking compartment is aluminized steel
- 3" insulation on six sides of cooking compartment
- Incoloy sheathed oven heating elements
- Heavy duty, spring assisted, hinge-down door with latch
- One center rack guide with one chrome plated oven rack provided
- Sea rails and full width front mounted grab bar
- 2-3/4" wide full width front grease trough
- Grease drain in trough with full width & depth spillage drawers
- Griddle top configurations include one piece welded splash guard back & sides
- 6" adjustable legs w/bolt-down flange standard

PERFORMANCE FEATURES

- Multi-function 36" wide unit fits into most marine galleys
- Hatchable two-piece design allows movement through 26" X 66" watertight hatch
- Choice of 7 cook-top configurations, to include:
 - 24" wide, 1/2" thick Griddle & 2 ea. 8" diameter French plates
 - 3 ea. 12" wide Hot Plates
 - 2 ea. 12" wide Hot Plates & 2 ea. 8" diameter French Plates
 - 36" wide, 1/2" thick Griddle
 - 6 ea. 8" diameter French Plates
 - 1 ea. 12" wide, 1/2" thick Griddle & 4 ea. 8" diameter French plates
- Full front grease trough, grease drain & spillage drawers speed range cleanup.
- Separate, independent controls allow precise multi-function cooking
- Oven holds one 18" X 26" full sheet pan

CONTROLS [Varies by Top Configuration]

- 150-550°F oven thermostat
- Top & bottom element 3-heat switches
- Damper control
- 60 minute timer with alarm
- [-ATAM] Two 450°F thermostats, one per 12" of Griddle plate & two 6-heat switches [French Plates]
- [-ATBM] Three individual 850°F thermostats [Hot Tops]
- [-ATCM] Two 850°F thermostats [Hot Tops] & two 6-heat switches [French Plates]
- [-ATDM & -ATDS] Three 450° thermostats, one per 12" of Griddle plate
- [-ATEM] Six 6-heat switches [French Plates]
- [-ATFM] One 850°F thermostat [Hot Top], Four 6-heat switches [French Plates]

36" Electric Range with Standard Oven Base *Marine Models

Model Has:	R36S-ATAM	R36S-ATBM	R36S-ATCM	R36S-ATDM	R36S-ATEM	R36S-ATFM
Oven Base:	Standard	Standard	Standard	Standard	Standard	Standard
Griddle:	24" wide	-	-	36" wide	-	-
French Plates:	2 each	-	2 each	-	6 each	4 each
Hot Plates:	-	3 each	2 each	-	-	1 each
Pictogram: [Unit top view]						

INSTALLATION REQUIREMENTS

- Single 208V or 240V, 1/3-Phase; or standard 440V/480V 3-Phase electrical connection
- Consult local and marine codes
- Installation under approved vent hood required
- [Power connection from bottom. See below]

OPTIONS

- Substitute 1" thick griddle plate
- Stainless Steel oven liner
- Grooving [requires 1" upgrade]

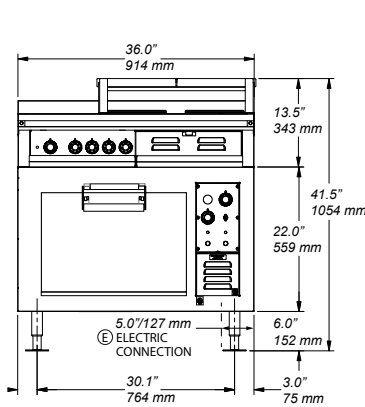

FRONT VIEW

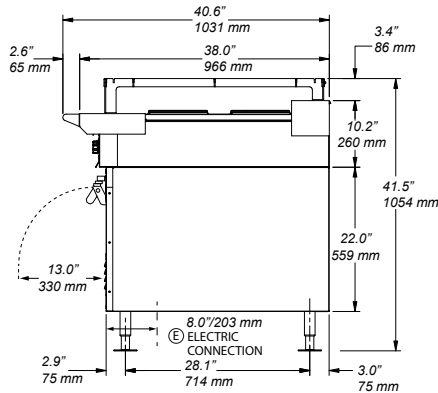

SIDE VIEW

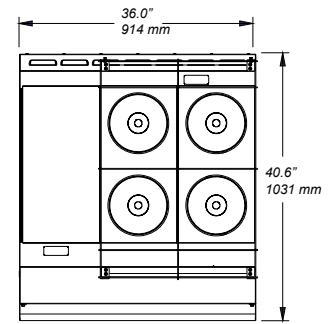

R36S-ATFM Configuration Shown

TOP VIEW

Model	Height x Width x Depth (with standard legs)	Clearance from combustible surface	Weight		Freight Class
			Actual	Shipping	
R36S (with standard oven)	41.7" x 36.0" x 40.6" 1053mm x 914mm x 1030mm	Sides: 4" (100mm) Back: 4" (100mm)	425-520** lbs. 193-236** kg	475-570** lbs. 216-259** kg	85

** Depending on configuration

Model	Volts AC - Hz	Total kW	Amps - Three Phase	Amps - Single Phase
R36S	208 - 60	21.0	66.7	101.0
	240 - 60	21.0	57.8	87.5
	440 - 60	17.6	26.5	N/A
	480 - 60	21.0	28.9	N/A

Due to continuous improvements, specifications subject to change without notice

