



Project \_\_\_\_\_  
 AIA # \_\_\_\_\_ SIS # \_\_\_\_\_  
 Item # \_\_\_\_\_ Quantity \_\_\_\_\_ C.S.I. Section 114000

## R Series

Roll-In Heated Cabinet Model  
 66" High Rack, 32" Deep



### STANDARD PRODUCT FEATURES

- Stainless Steel Exterior & Interior
- Traulsen's Smart Control™ with LED Display
- Ducted Fan Air Distribution System
- Standard Operating Temperature Range 140 to 180°F
- ON/OFF Switch Located on Control Face
- Full-Height Stainless Steel Door with Lock
- Self-Closing Door with Stay Open Feature
- Standard Door Hinging: 132L = Right (other hings available)
- Automatically Activated LED Lights
- Stainless Steel Breaker Caps
- Accommodates Roll-In Racks Up to 66" High (provided by others)
- Magnetic Snap-In EZ-Clean™ Door Gasket
- Stainless Steel Door Liner
- Stainless Steel Interior Rack Guides
- Stainless Steel Threshold Ramp
- Stainless Steel One-Piece Louver Assembly
- 9' Cord & Plug Attached

### ACCESSORIES & OPTIONS

- SmartConnect™ Monitoring App with Wi-Fi Connectivity
- Stainless Steel Finished Back with Rear Louvers
- Coated Wire Shelf Package (includes 3 shelves per section)
- Additional Coated Wire Shelves for Above
- Rehinging Feature (consult factory)
- Stainless Steel Shelf Package (includes 3 shelves per section)
- Additional Stainless Steel Shelves for Above
- Locking Hasps (padlocks supplied by others)
- Optional 115/60/1 or 208-230/60/1 Voltage
- Kool Klad™ Exterior Laminate Decor
- Clear Glass Door in Place of Solid Door
- Heat Shield
- Stainless Steel Banking Strip
- Transition Strip for Recessed Floor Installation
- Prison/Correctional Facility Options

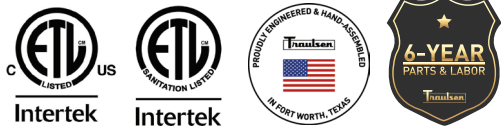

Models listed to the applicable UL, CSA and NSF standards by an approved NRTL. Consult the factory or unit data plate for additional information.

### AVAILABLE CONFIGURATIONS

R Series Models  
 RIH132L-FHS

Doors  
 Full Height Solid

- GUARANTEED FOR LIFE CAM-LIFT HINGES
- GUARANTEED FOR LIFE HORIZONTAL WORKFLOW DOOR HANDLES



ENERGY STAR® Listed Commercial Hot Food Holding Cabinet  
 For full listing visit [energystar.gov](http://energystar.gov)

Approved by \_\_\_\_\_ Date \_\_\_\_\_ Approved by \_\_\_\_\_ Date \_\_\_\_\_

MODEL:

RIH132L-FHS

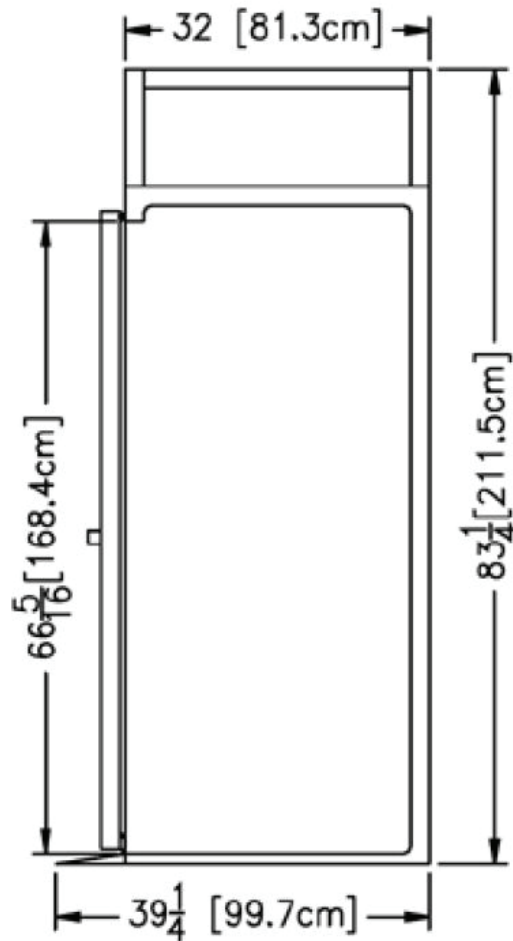
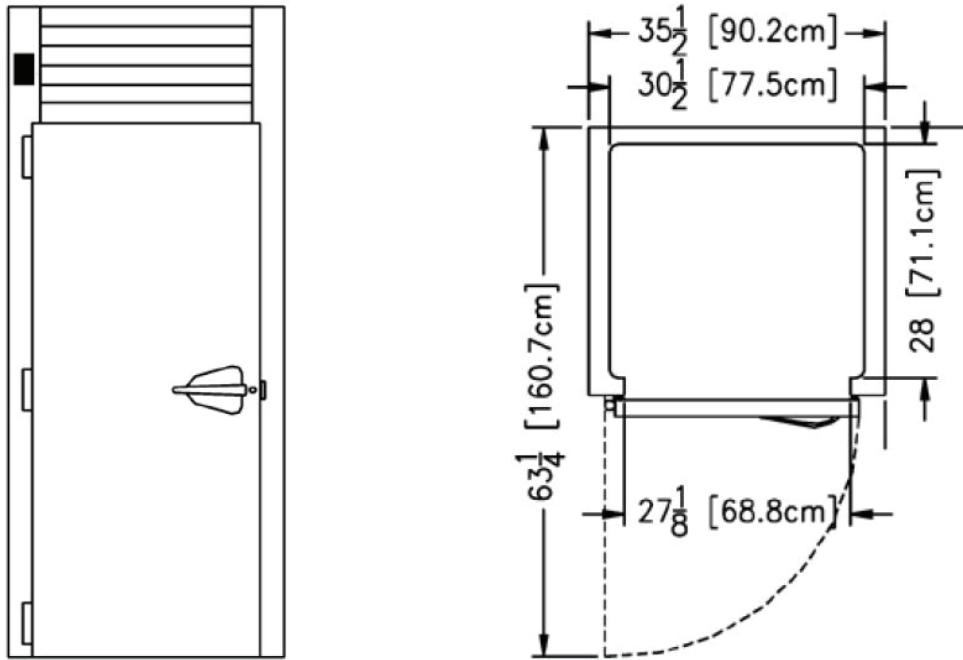

➤ CAD and/or Revit Files Available

<https://traulsen.klccad.com/>

**MODEL:**

RIH132L-FHS

MODELS	RIH132L-FHS
<b>DIMENSIONAL DATA</b>	
Net capacity cu. ft.	35.3 (999.6 cu l)
Length - overall in.	35 1/2" (90.2 cm)
Depth - overall in.	39 1/4" (99.7 cm)
Depth - over body in.	32" (81.3 cm)
Depth - door open 90° in.	63 1/4" (160.7 cm)
Clear door width in. <sup>1</sup>	27 1/8" (68.8 cm)
Clear door height in.	66 5/16" (168.4 cm)
Height - overall in.	83 1/4" (211.5 cm)
Capacity - 66" High	1
<b>ELECTRICAL DATA</b>	
Voltage   Plug	208-230/115/60/1   NEMA L14-20P
Heater Wattage   Full Load Amperes	@208V = 1500   7.7 @230V = 1836   8.5 @240V = 2000   8.8 @115V = 1500   14.2
<b>SHIPPING DATA</b>	
Length - Crated in.	48" (121.9 cm)
Depth - Crated in.	42" (106.7 cm)
Height - Crated in.	94" (238.8 cm)
Volume - Crated cu. ft.	109.67 (3105.5 cu l)
Weight - Crated lbs.	497 (225.4 kg)

NOTES: Figures in parentheses reflect metric equivalents.

1. Please note that the available cabinet width narrows for 6" from the top of the door frame to 25 7/8" in order to allow for the heater fans.
2. Heater is capable of operation from 208V to 230V as supplied standard. Actual amp figure will change at any voltage other than 208V.

When ordering please specify: Voltage, Hinging, and Options.

Equipped with one NEMA L14-20P Plug   
(1 section models @ 208V only)

**EQUIPMENT SPECIFICATIONS**

**CONSTRUCTION, HARDWARE, INSULATION**

The interior is made from stainless steel and the cabinet exterior front, one piece sides, louver assembly, doors and door liners are constructed of heavy gauge stainless steel. The interior floor and exterior bottom are constructed of stainless steel & insulated with 3/4" of resilient cork. A readily attachable stainless steel ramps are provided.

Door is equipped with heavy-duty, extruded wiper gasket for sealing to bottom ramp, removable plug cylinder locks & guaranteed for life gravity action, self-closing metal, cam-lift hinges with a stay open feature. Hinges include a concealed switch to automatically activate the interior LED lighting. Guaranteed for life, workflow door handles are mounted horizontally over recess in door which limits protrusion from door face into aiseways. Door has seamless, polished metal corners.

Gasket profile & material simplify cleaning & increase overall gasket life. Both the cabinet and door are insulated with an average 2" thick high density, non-CFC, foamed in place polyurethane.

**HEATING SYSTEM**

A low watt density, serpentine style, heater is employed for the generation of electric heat. Low velocity air is forced across its large surface area to efficiently move heat radiating away from these through a down-air distribution duct, where it is then evenly distributed throughout the cabinet, assuring the proper holding environment for hot food product, without drying. A vent, located at the top of the cabinet is included for positive humidity control.

**CONTROL**

Traulsen's Smart Control™ features advanced control algorithms & sophisticated diagnostic capabilities to optimize performance. Utilizing smart sensors, it adapts the operation of the heating system to a variety of environments & usage patterns. The Smart Control™ also offers a complete set of visual alarms designed to alert the user to critical events such as power outages or a prolonged door opening. In the event of an alarm, a dedicated Alarm LED will illuminate, informing the user of the critical event and duration.

**INTERIOR**

Readily removable, interior-mounted, stainless steel guides for racks are provided for protection. Maximum rack size with wheels inboard of frame is 27" wide by 29" deep by 66" high. Racks are supplied by others.

**WARRANTY**

A six year parts & labor warranty is provided standard.