



TRUE MANUFACTURING CO., INC.
U.S.A. FOODSERVICE DIVISION

2001 East Terra Lane • O'Fallon, Missouri 63366-4434 • (636)240-2400
Fax (636)272-2408 • Toll Free (800)325-6152 • Intl Fax# (001)636-272-7546
Parts Dept. (800)424-TRUE • Parts Dept. Fax# (636)272-9471 • www.truemfg.com

Project Name: _____

Location: _____

Item #: _____ Qty: _____

Model #: _____

A/A #

S/S #

Model:
TUC-67D-2-HC

Deep Undercounter:
Drawered Refrigerator with Hydrocarbon Refrigerant



TUC-67D-2-HC

- ▶ True's deep undercounter units feature the combined advantage of undercounter placement with deeper refrigerated storage.
- ▶ Designed using the highest quality materials and components to provide the user with colder product temperatures, lower utility costs, exceptional food safety and the best value in today's food service marketplace.
- ▶ Factory engineered, self-contained, capillary tube system using environmentally friendly R290 hydro carbon refrigerant that has zero (0) ozone depletion potential (ODP), & 0.02 global warming potential (GWP).
- ▶ High capacity, factory balanced refrigeration system that maintains cabinet temperatures of 33°F to 38°F (5°C to 3.3°C) for the best in food preservation.
- ▶ All stainless steel front, top and ends. Corrosion resistant GalFan coated steel back.
- ▶ Interior - attractive, clear coated aluminum liner with stainless steel floor.
- ▶ Each drawer accommodates two (2) full size 12"L x 20"D x 8"H (305 mm x 508 mm x 204 mm) food pans (sold separately).
- ▶ Foamed-in-place using a high density, polyurethane insulation that has zero ozone depletion potential (ODP) and zero global warming potential (GWP).

Castor Options

36"
Work Surface
Height



Standard 5" Castors

34"
Work Surface
Height



ADA 3" Castors

31-7/8"
Work Surface
Height



Low Profile (LP) 1½" Castors
Upcharge applies for (LP) size castors

ROUGH-IN DATA

Specifications subject to change without notice.
Chart dimensions rounded up to the nearest 1/8" (millimeters rounded up to next whole number).

Model	Doors	Drawers	Cabinet Dimensions (inches) (mm)			HP	Voltage	Amps	NEMA Config.	Cord Length (total ft.) (total m)	Crated Weight (lbs.) (kg)
			W	D†	H*						
TUC-67D-2-HC	1	2	67¼ 1709	32¼ 820	29¾ 756	1/10 N/A	115/60/1	1.7 N/A	5-15P	10 3.05	385 175

† Depth does not include 1" (26 mm) for rear and ¼" (7 mm) for front bumpers.
* Height does not include 6¼" (159 mm) for castors or 6" (153 mm) for optional legs.



APPROVALS:

AVAILABLE AT:

Model:
TUC-67D-2-HC

Deep Undercounter: Drawered Refrigerator with Hydrocarbon Refrigerant



STANDARD FEATURES

DESIGN

- True's deep undercounter units are designed with enduring quality that protects your long term investment.
- True's commitment to using the highest quality materials and oversized refrigeration systems provides the user with colder product temperatures, lower utility costs, exceptional food safety and the best value in today's food service marketplace.

REFRIGERATION SYSTEM

- Factory engineered, self-contained, capillary tube system using environmentally friendly R290 hydro carbon refrigerant that has zero (0) ozone depletion potential (ODP), & 0.02 global warming potential (GWP).
- Energy efficient, factory balanced refrigeration system with guided airflow to provide uniform product temperatures.
- High capacity, factory balanced refrigeration system that maintains cabinet temperatures of 33°F to 38°F (.5°C to 3.3°C) for the best in food preservation.
- State of the art, electronically commutated evaporator and condenser fan motors. ECM motors operate at higher peak efficiencies and move a more consistent volume of air which produces less heat, reduces energy consumption and provides greater motor reliability.
- Condensing unit is accessed from behind front grill; slides out for easy maintenance.

CABINET CONSTRUCTION

- Exterior - stainless steel front, top and ends. Corrosion resistant GalFan coated steel back.
- Interior - attractive, clear coated aluminum liner. Stainless steel floor with coved corners.

- Insulation - entire cabinet structure and drawer facings are foamed-in-place using a high density, polyurethane insulation that has zero ozone depletion potential (ODP) and zero global warming potential (GWP).
- 5" (127 mm) diameter stem castors - locks provided on front set. 36" (915 mm) work surface height.

DOOR / DRAWERS

- Door or drawer assemblies can be located in any section of the cabinet. Location of door/drawers must be indicated at time of ordering.
- Door constructed of stainless steel exterior with clear aluminum liner to match cabinet interior. Drawers have stainless steel exterior facings and liners with stainless steel frames.
- Each door and drawer fitted with 12" (305 mm) long recessed handle that is foamed-in-place with a sheet metal interlock to ensure permanent attachment.
- Door section - positive seal door swing with cabinet dimensions.
- Magnetic drawer/door gaskets of one piece construction, removable without tools for ease of cleaning.
- Drawer section - Heavy-duty stainless steel drawer slides and rollers. Removable without tools for easy cleaning.
- Each drawer accommodates (2) 12" L x 20" W x 8" D (305 mm x 508 mm x 204 mm) food pans (sold separately)

SHELVING

- Two (2) adjustable, heavy duty PVC coated wire shelves 235/8" L x 28" D (601 mm x 712 mm). Four (4) chrome plated shelf clips included per shelf.

- Shelf support pilasters made of same material as cabinet interior; shelves are adjustable on 1/2" (13 mm) increments.

MODEL FEATURES

- Evaporator is epoxy coated to eliminate the potential of corrosion.
- Drawers will support a wide variety of incremental pan size configurations; divider bars available.
- NSF/ANSI Standard 7 compliant for open food product.

ELECTRICAL

- Unit completely pre-wired at factory and ready for final connection to a 115/60/1 phase, 15 amp dedicated outlet. Cord and plug set included.



115/60/1
NEMA-5-15R

OPTIONAL FEATURES/ACCESSORIES

Upcharge and lead times may apply.

- 6" (153 mm) standard legs.
- 6" (153 mm) seismic/flanged legs.
- 2 1/2" (64 mm) diameter castors.
- White aluminum interior liner. Stainless floor with coved corners.
- Single overshef.
- Double overshef.
- 32 1/8" (816 mm) deep, 1/2" (13 mm) thick, white polyethylene cutting board. Requires "L" brackets.
- 32 1/8" (816 mm) deep, 1/2" (13 mm) thick, composite cutting board. Requires "L" brackets.
- Heavy duty 16 gauge tops.
- Heavy duty package - 16 gauge tops, 20 gauge door, sides and back with stainless interior.
- Exterior round digital temperature display (factory installed).
- Barrel locks (factory installed).

PLAN VIEW

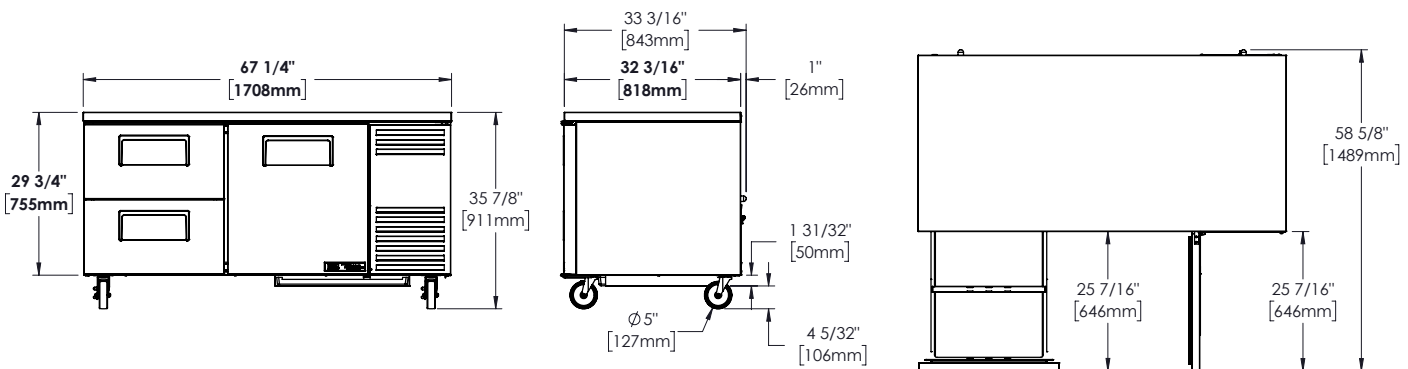

METRIC DIMENSIONS ROUNDED UP TO THE NEAREST WHOLE MILLIMETER

SPECIFICATIONS SUBJECT TO CHANGE WITHOUT NOTICE



Model	Elevation	Right	Plan	3D	Back
TUC-67D-2-HC					

TRUE MANUFACTURING CO., INC.

2001 East Terra Lane • O'Fallon, Missouri 63366-4434 • (636)240-2400 • Fax (636)272-2408 • Toll Free (800)325-6152 • Intl. Fax# (001)636-272-7546 • www.truefmfg.com