



BEVERAGE-AIR®

PROJECT: _____
 ITEM # _____ QTY: _____
 MODEL # _____
 AIA # _____ SIS # _____
 APPROVED: _____

SANDWICH PREP TABLES

Model: SPED48HC-10-2

TWO DRAWERS ONE DOOR STANDARD TOP



7 YEAR WARRANTY Parts, Labor, and Compressor

CABINET CONSTRUCTION

- Stainless steel front, sides, top, drawers, and grille (galvanized steel back & bottom)
- Interior liner is made of corrosion resistant aluminum
- Removable hoods made of matching stainless steel
- Full electronic control
- Airflow assures that product in open containers is kept below 41°F and above freezing
- (10) 1/6 size 4" deep pans constructed of polycarbonate plastic
- Pans furnished are 4" deep constructed of polycarbonate plastic
- Snap-in magnetic gaskets for positive drawer seal
- Painted aluminum handles
- 10" Wide cutting board constructed of white polyethylene plastic
- Cutting board removable for cleaning
- Self-closing door with 120° stay-open feature, on cartridge style hinges
- Easy door removal for service and cleaning
- Field-reversible door (hinge kit not included)
- Snap-in magnetic gaskets for positive door seal
- Painted aluminum handles
- Two (2) epoxy coated wire shelves
- Stainless steel drawer frames supported on telescoping drawer slides
- Drawer slides include locking mechanism that prevents drawers from being inadvertently pulled off cabinet
- 6" Casters, with (2) brakes standard



OPTIONS & ACCESSORIES

- Stainless steel back
- Stainless steel interior
- Clear lid
- Overshelves (single or double)
- Crumb catcher kit
- Left hinged door (at time of order)
- Door lock
- Overshelves (single or double)
- Epoxy coated shelves
- Shelf clips
- Shelf dividers
- Richlite cutting board
- Night cover
- Bottle organizer
- Pan supports
- Pan support crossbar
- Pan configuration
- Locking divider
- 6" Legs or 3" casters
- Low profile casters
- Remote option* (see note on back page)

REFRIGERATION SYSTEM

- Uses environmentally friendly, energy efficient R290 refrigerant, and meets all regulatory requirements for CARB, SNAP, DOE & more
- Adaptive defrost
- Epoxy coated evaporator coil
- Enhanced airflow maintains temperature between 36° to 38°

3779 Champion Blvd., Winston-Salem, NC 27105
 888-845-9800 Fax: 336-245-6453
 Beverage-Air.com Sales@bevair.com



Please verify qualifying units by visiting:
www.energystar.gov/cfs

Specifications are subject to change without prior notice.
 Date Issued 2/26 Printed in U.S.A.

BEVERAGE-AIR®

Sandwich Prep Tables Model: SPED48HC-10-2

PLAN VIEW

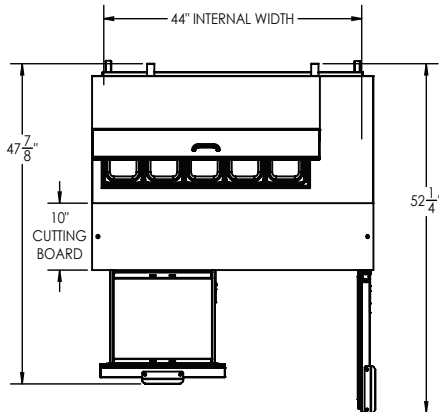

ELEVATION VIEW

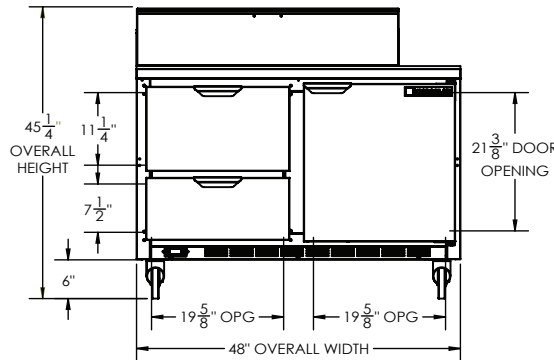

SIDE VIEW

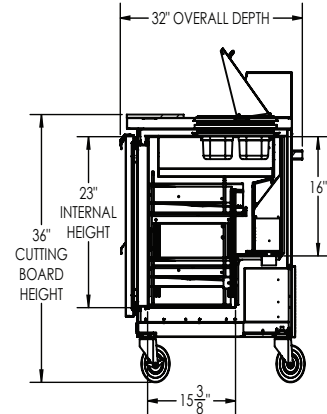

Required Clearance: 3" Bottom & 2" Rear

EXTERNAL DIMENSIONAL DATA

Width Overall (in)	48"
Depth Overall (in)	32"
Height Overall (in)	45 1/4"
Number of Doors	1
Number of Drawers	2
Depth with Door Open 90°	52 1/4"
Door opening (in.)	19 5/8" x 21 3/8"
Depth, Cutting Board	10"

INTERNAL DIMENSIONAL DATA

NET Capacity (cubic ft.)	13.01
Internal Width Overall (in)	44"
Internal Depth Overall (in)	15 3/8"
Internal Height Overall (in)	23"
Number of Shelves	2
Depth with Drawers Open	47 7/8"
Drawers Openings	19 5/8" x 11 1/4" 19 5/8" x 7 1/2"

*NOTE: Remote units are field wired and come with 6" legs. Refrigerant must be specified at time of order.

ELECTRICAL DATA

Full Load Amps	2
Voltage	115/60/1
Nema Plug (8' cord)	5-15P

REFRIGERATION DATA

Horsepower	1/6
Capacity (BTU/Hr)	1094
Heat Rejection (BTU/Hr)	1641
Charge (lbs/grams/ounces)	0.243 / 110 / 3.89

SHIPPING DATA

Gross Weight - Crated	326 lbs.
Height - Crated (in)	44"
Width - Crated (in)	51"
Depth - Crated (in)	35"

ELECTRICAL CONNECTION



115/60/1
NEMA 5-15P

Unit pre-wired at factory and include 8' long cord and plug set.

We reserve the right to change specifications and product design without notice. Such revisions do not entitle the buyer to corresponding changes, improvements, additions or replacements for previously purchased equipment. Dimensional tolerances +/- 1/4". Metric dimensions (MM).

3779 Champion Blvd., Winston-Salem, NC 27105 | 888-845-9800 | Fax: 336-245-6453 | Beverage-Air.com | Sales@bevair.com

Date Issued 2/26 | Printed in U.S.A.