



KC72 with stainless doors, stainless top, and 3 faucet column tower.



**Intertek**

4004503

Conforms to NSF/ANSI STD 7 and UL STD 471

Certified to CSA STD C22.2 No. 120

Meets NSF 7 requirements for closed container products



**Intertek**



**Intertek**

EP 5016978

Energy Performance Verified / Rendement Énergétique Vérifié

Intended for indoor use.

### Standard Features

- Self-contained
- Galvanized steel interior with stainless steel floor
- Locking doors
- Stainless steel keg racks and 1/2" thick high impact polypropylene threshold scuff plate
- Heated mullion to minimize condensation
- Stainless steel evaporator housing with separate removable evaporator drain pan

Project: _____	AIA# _____
Item #: _____ Qty: _____	SIS# _____
Model #: _____	

## Keg Cooler 72" Self-Contained

KC	KC72
----	------



### Configurable Options

- Temperature:**
- Beer - 34°F to 40°F
  - White wine - 50°F to 55°F
  - Red wine - 60°F to 65°F
- Refrigeration Compartment Location:**
- Left or Right
- Front Finish:**
- Black vinyl-clad
  - Stainless steel
- Door Hinge Location (specify for each door):**
- Left or Right
- Door Handle:**
- Signature
  - Pull-tab
  - Tube
- Top Style:**
- No finished top
  - Stainless top
- Left and Right Side Finish:**
- Black vinyl-clad
  - Stainless steel
- Back Finish:**
- Galvanized steel
  - Stainless steel
- Tower Style:**
- Column (CT)
  - Beverage (BT)
- Tower Finish**
- Stainless
  - Mirror
  - Brass
- Faucet(s)**
- 1, 2, or 3 for CT
  - 4, 5, 6, 8, or 10 for BT

<b>Glastender, Inc.</b> • 5400 N Michigan Rd • Saginaw, MI • 48604-9780 989.752.4275 • 800.748.0423 • Fax 989.752.4444 <a href="http://www.glastender.com">www.glastender.com</a>	Approval/Notes:
Specifications subject to change without notice. For current specifications please visit our website.	

# Keg Cooler 72" Self-Contained

## Specifications

		KC72
Dimensions	Length	72"
	Number of Sections	2
	Door Opening	20"
Electrical	Electrical Supply	120V, 1 phase, 60 Hz, dedicated 15A circuit required
	Full Load Amps	3.5
	Plug Type	8 foot NEMA 5-15P grounded cord and plug which exits the back of refrigeration compartment
Refrigeration	Refrigerant	R290 refrigerant - 125 grams, 4.41 oz., 0.28 pounds
	Compressor	Reciprocating, 1/6 HP, 1300 BTUH, 0.11 Tons
	Heat Rejection	1430 BTUH
Operating Range		34°F (1°C) to 65°F (18°C)
Plumbing		Automatic condensate evaporator. No drain connection required †
Weight Bearing Capacity		Countertops and other accessories should not exceed 500 pounds per door

### Materials

- Stainless steel parts include: exterior sub-top, interior floor, evaporator cover, front of cabinet, hinges, hinge and lock brackets, and optional legs
- Black vinyl-clad steel parts include: standard sides, doors, and compressor cover
- Galvanized steel parts include: interior walls and ceiling, back and bottom

### Plumbing

- 1/2" tailpiece provided on drain pan and pre-plumbed drain line which exists out the bottom of the refrigeration compartment

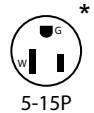

† Building conditions outside the guidelines of ASHRAE 55 and ASHRE 62.1 may need to be plumbed to a drain.

## Capacities

	KC72
1/2 Barrels	3
1/6 Barrels*	11

\*Consult factory for different tower options

# Keg Cooler 72" Self-Contained

## Drawings

### PLAN VIEW

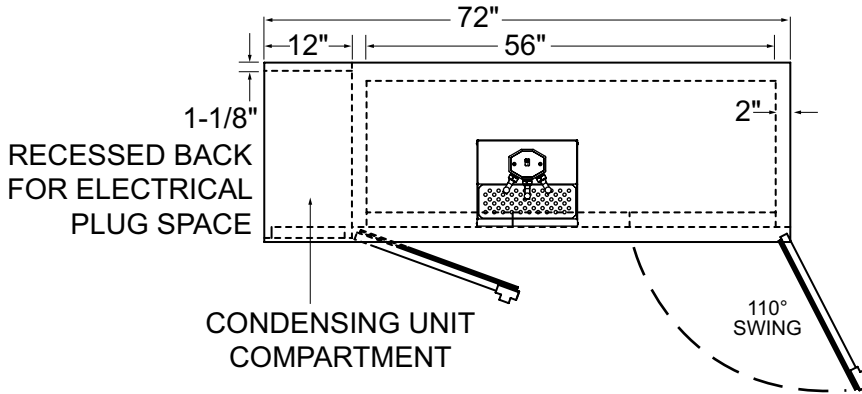

### FRONT ELEVATION

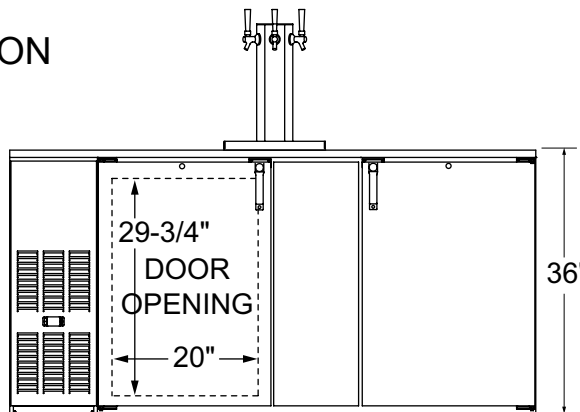

### SIDE ELEVATION

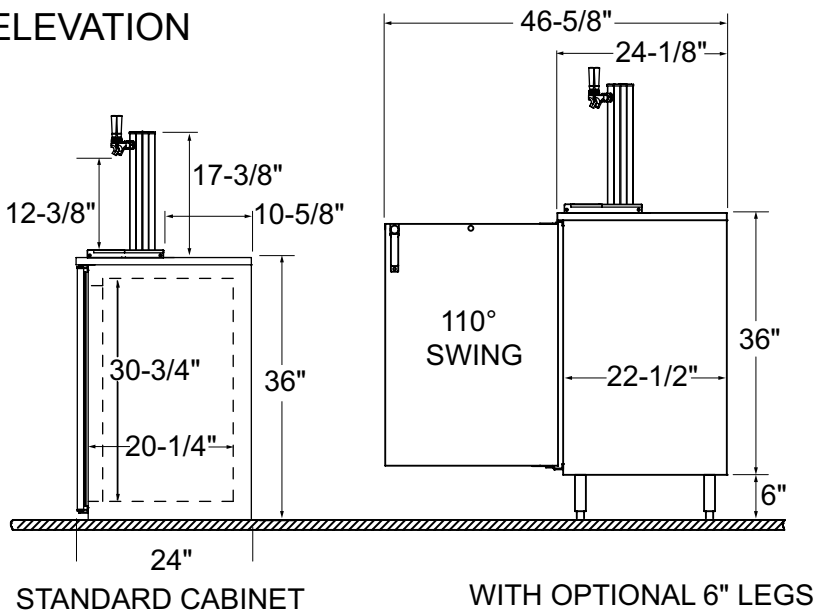

### OPTIONAL LEGS AND CASTERS

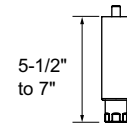

6" LEG

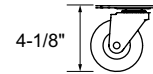

4-1/8" CASTER

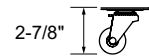

2-7/8" CASTER

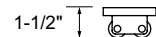

1-1/2" CASTER

NOTE: ALL DRAWINGS SHOWN WITH CT-3 COLUMN DRAFTBEVERAGE TOWER



5400 N Michigan Rd • Saginaw, MI • 48604-9780  
989.752.4275 • 800.748.0423 • Fax 989.752.4444  
www.glastender.com

Printed in USA

## Direct Draw Draft Beverage Towers and Accessories



### Configuring Bar Profile Coolers for Draft Beverage Dispensing

All Glastender bar profile coolers can be configured for draft beverage dispensing. Please note that a minimum 17" wide door opening is required for full size (i.e., 16" diameter) 1/2 barrel kegs. Refer to the capacity statements in the Product Directory or Specification Sheet for the sizes and quantities of kegs each unit will hold.

### Direct Draw Draft Beverage Towers

Glastender Beverage Towers include the stainless steel faucets and shanks necessary to dispense keg beer, wine, soda, coffee, or cocktails. See individual price pages for complete information.

Tee Tower shown  
See individual tower  
spec sheets for  
complete information

Look for the Draft Beer  
Compatible logo



### HIGH PRESSURE REGULATOR KITS

High pressure regulators reduce the gas pressure from the primary source. A tank mount regulator attaches directly to a gas cylinder, while a wall mount regulator splices into gas tubing when the gas supply is used for more than one system. RKH-TN regulator kits are used if pre-blended CO<sub>2</sub> and nitrogen or pure nitrogen cylinders are being used. All high pressure regulator kits include 50 feet of braided nylon gas tubing.

MODEL	DESCRIPTION	WGT
RKH-W	Wall mount, CO <sub>2</sub> or Nitrogen, single gauge	15#
RKH-TC	Tank mount, CO <sub>2</sub> , double gauge	15#
RKH-TN	Tank mount, Nitrogen, double gauge	15#

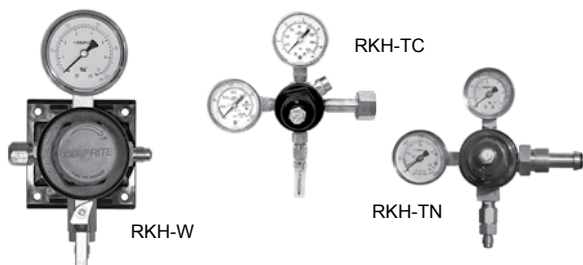

### LOW PRESSURE REGULATOR KITS

Low pressure regulator kits connect to the gas tubing exiting a high pressure regulator. If a 5 pound gas cylinder will be kept inside the cooler, a single gauge tank mounted RKL-TC or -TN will be required depending on the gas being used. All low pressure regulator kits include 6 feet of red gas tubing. For installations requiring more than one keg on tap, also order the appropriate size manifold kit. All manifold kits include 6 feet of red gas tubing per product, and the clamps required for connecting to keg couplers (sold separately).

MODEL	DESCRIPTION	WGT
RKL-W	Wall mount, CO <sub>2</sub> or Nitrogen, single gauge	7#
RKL-TC	Tank mount, CO <sub>2</sub> , single gauge	7#
RKL-TN	Tank mount, Nitrogen, single gauge	7#
MAN2	Two product manifold kit	2#
MAN3	Three product manifold kit	3#
MAN4	Four product manifold kit	4#
MAN5	Five product manifold kit	5#
MAN6	Six product manifold kit	6#

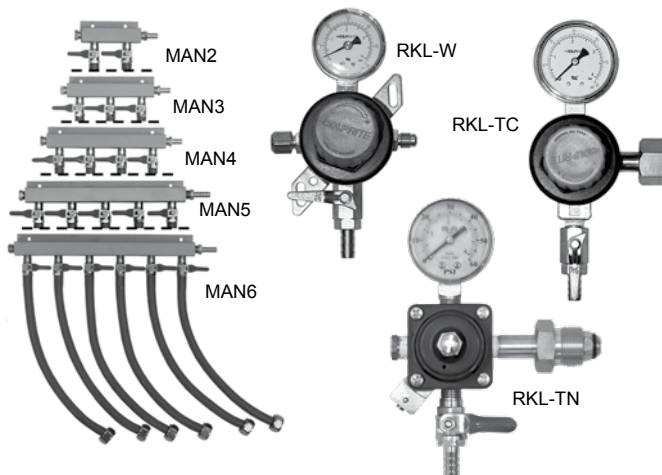

### ADDITIONAL ACCESSORIES

MODEL	DESCRIPTION	WGT
03004240	1/2" ID black drain line, per foot	N/A
05000400	5/16" ID red vinyl air line, per foot	N/A
05000386	1/4" ID nylon braided gas tubing, per foot	N/A
05001066	D system keg coupler w/ss probe	2#
05001026	D system keg coupler, low profile	2#
05003763	S system keg coupler w/ss probe, for select imports	2#
05002019	U System Keg Coupler, stainless probe, for Guinness & Harp	2#
05000368	Lock for beer faucet	2#
05000636	5# CO <sub>2</sub> tank (unfilled)	15#
LCK	Line cleaning kit	3#
06007084	Drain bottle	2#



### Tower Cooling Kits

Direct draw beverage towers are chilled by air from inside the host cooler. This is especially important for draft beer, as warm faucets cause the beer to foam.

### TOWER COOLING KITS

MODEL	DESCRIPTION	WGT
TCK12-1	For 1 & 2-door coolers w/ one tower column	3#
TCK12-2	For 1 & 2-door coolers w/ two tower columns	6#
TCK34-1	For 3 & 4-door coolers w/ one tower column	8#
TCK34-2	For 3 & 4-door coolers w/ two tower columns	11#
TCKR-1	For remote coolers w/ one tower column	3#
TCKR-2	For remote coolers w/ two tower columns	6#

# Glastender

5400 N Michigan Rd • Saginaw, MI • 48604-9780  
989.752.4275 • 800.748.0423 • Fax 989.752.4444  
www.glastender.com

Printed in USA