

Curved Glass Deli Case

KOOL-IT

KDG-36 | KDG-48 | KDG-60 | KDG-80



KDG-48

Kool-it KDG refrigerated deli case offers both functionality and style. Its eco-friendly refrigerant and powerful refrigeration system work together to maintain optimal temperatures while minimizing environmental impact.

Ideal for delis, bakeries, and coffee shops, this unit is perfect for showcasing specialty items and increasing impulse purchases.

Durable Design

- Interior Stainless steel
- Exterior coated black metal paint
- The pan size 14.2" x 6.5" x 4.7"
- Rear acrylic sliding doors.
- Double-pane heated clear glass with heater inside
- Equipped with 4 casters (2 with brakes)
- Comes standard with 2 adjustable shelves

Superior Quality

- Gravity coil refrigeration system delivers reliable preservation of food products
- Slide-out condensing unit for easy maintenance
- ETL approved (conforms to UL-471 and NSF-7)
- Ozone friendly R290 refrigerant

Energy Efficient

- Auto defrost system for front glass and rear door frame
- Digital temperature control with 35°-41°F holding range
- DOE2017 energy standard compliant
- LED lighting



Warranty: 1 Year parts and labor. *Additional 48months on compressor (part only)
KOOL-IT is a registered trademark of MVP Group. Specifications subject to change without notice.



www.mvpgroupcorp.com



3560 NW 56th Street
Fort Lauderdale, FL 33309
Tel.: 786.600.4687 / Toll Free: 844.218.8477

sales@mvpgroupcorp.com

Curved Glass Deli Case



KDG-36 | KDG-48 | KDG-60 | KDG-80

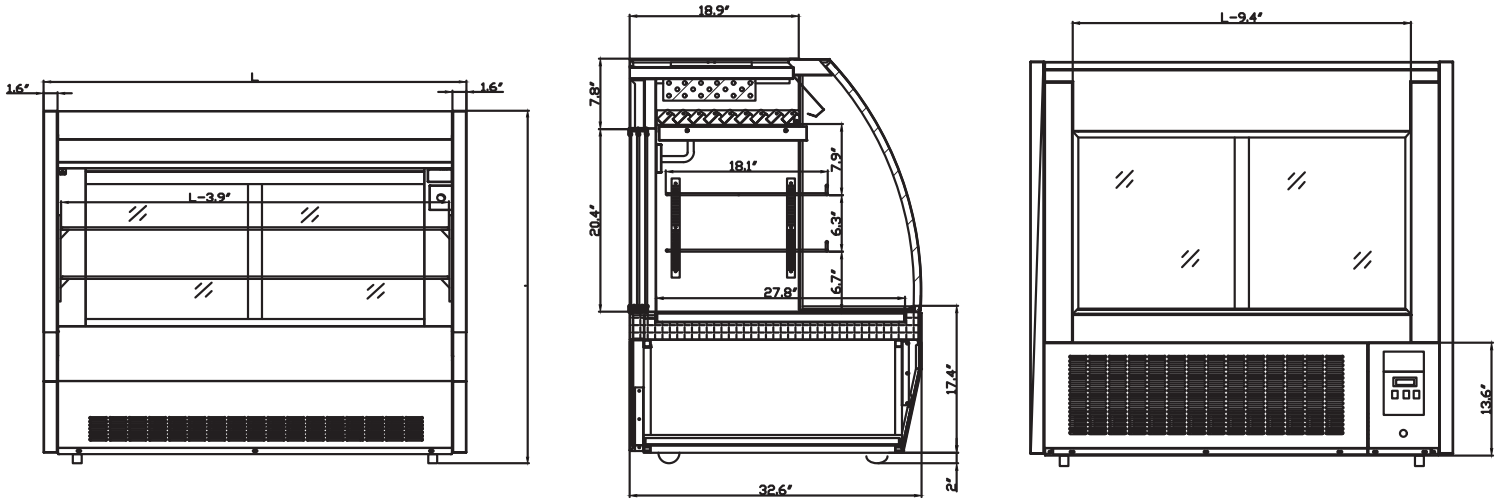

MODEL	DOORS	CAPACITY (cu.ft)	SHELVES	CABINET DIMENSIONS (Inches / mm) WxDxH	COMPRESSOR SIZE (HP)	VOLTAGE	AMPS	CORD LENGTH (ft.)	NET WEIGHT (lbs. / Kg)
KDG-36	2	12	2	35.6" x 32.5" x 48.2" 900 mm x 825mm x 1150mm	1/3	110V/60Hz	4.50	6	410 186
KDG-48	2	18	2	47.7" x 32.5" x 48.2" 1200 mm x 825mm x 1150mm	1/3	110V/60Hz	5.00	6	496 225
KDG-60	2	21.5	2	59" x 32.5" x 48.2" 1500 mm x 825mm x 1150mm	3/5	110V/60Hz	5.80	6	573 260
KDG-80	2	26.4	2	79.2" x 32.5" x 48.2" 2012 mm x 825mm x 1150mm	3/4	110V/60Hz	6.40	6	650 295

The refrigerated KDG series cases are engineered to operate in locations not exceeding 80°F and 55% relative humidity.



Warranty: 1 Year parts and labor. *Additional 48months on compressor (part only)
KOOL-IT is a registered trademark of MVP Group. Specifications subject to change without notice.



www.mvpgroupcorp.com



3560 NW 56th Street
Fort Lauderdale, FL 33309
Tel.: 786.600.4687 / Toll Free: 844.218.8477

sales@mvpgroupcorp.com