



# BEVERAGE-AIR®

PROJECT: \_\_\_\_\_  
 ITEM # \_\_\_\_\_ QTY: \_\_\_\_\_  
 MODEL # \_\_\_\_\_  
 AIA # \_\_\_\_\_ SIS # \_\_\_\_\_  
 APPROVED: \_\_\_\_\_

## MILK COOLERS

### Model: SMF49HC-1-W

FORCED AIR / SINGLE ACCESS

## 7 YEAR WARRANTY

Parts, Labor, and Compressor

### CABINET CONSTRUCTION



- White coated steel exterior
- Interior features a one-piece, stainless steel back, front, floor with galvanized side walls for maximum milk crate support
- Stainless steel lids, hinged doors and door latches
- Full electronic control
- Heavy-duty epoxy coated steel wire floor racks standard
- Floor drain is centrally located for easy cleaning and connecting to drain hose with hose adapter
- Flexible compression door gaskets, ensures a tight seal
- Self-latching doors/lids with safety bumpers
- Exterior thermometer
- Cylinder locks
- 6" Heavy-duty plate casters (2 with locks)
- Balanced, forced-air refrigeration system provides rapid chilling of product



### OPTIONS & ACCESSORIES

- Corner bumpers
- Cafeteria tray slides
- Graphics

### REFRIGERATION SYSTEM

- Uses environmentally friendly, energy efficient R290 refrigerant, and meets all regulatory requirements for CARB, SNAP, DOE & more
- Maintains product temperatures between 36°F to 40°F



PLAN VIEW

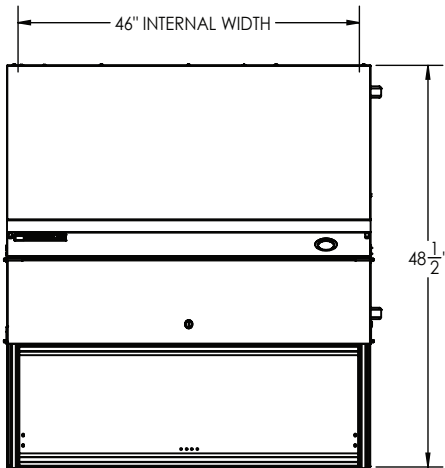

ELEVATION VIEW

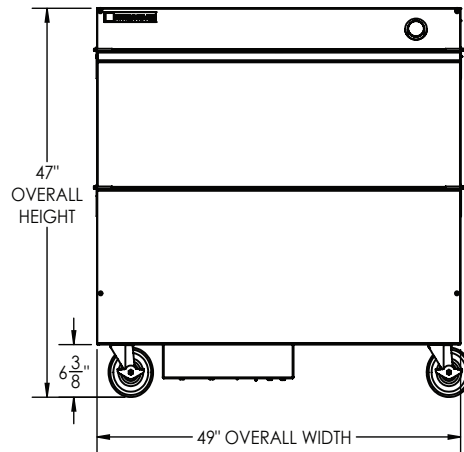

SIDE VIEW

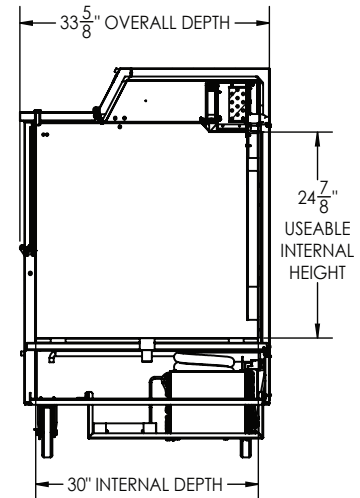

### EXTERNAL DIMENSIONAL DATA

Width Overall (in)	49"
Depth Overall (in)	33 5/8"
Height Overall (in)	46 7/8"
Number of Lids	Single Access
Depth with Door open 90° (in)	48 1/2"

### INTERNAL DIMENSIONAL DATA

NET Capacity (cubic ft.)	19.66
Internal Width Overall (in)	46"
Internal Depth Overall (in)	30"
Internal Height Overall (in)	24 7/8"
Case Capacity 13" X 13" X 11"	12
Case Capacity 19" X 13" X 11"	8

\*NOTE: Remote units are field wired and come with 6" legs.  
Refrigerant must be specified at time of order.

We reserve the right to change specifications and product design without notice. Such revisions do not entitle the buyer to corresponding changes, improvements, additions or replacements for previously purchased equipment. Dimensional tolerances +/- 1/4". Metric dimensions (MM).

Required Clearance: 4 3/8" bottom

### ELECTRICAL DATA

Full Load Amps	2.46
Voltage	115/60/1
Nema Plug (8' cord)	5-15P

### REFRIGERATION DATA

Horsepower	1/4
Capacity (BTU/Hr)	1851
Heat Rejection (BTU/Hr)	2776.5
Charge (lbs/grams/ounces)	0.1562 / 70.9 / 2.5

### SHIPPING DATA

Gross Weight - Crated	437 lbs.
Height - Crated (in)	48"
Width - Crated (in)	52"
Depth - Crated (in)	34"

### ELECTRICAL CONNECTION



115/60/1  
NEMA 5-15P

Unit pre-wired at factory and include 8' long cord and plug set.