



**FOOD EQUIPMENT**

*SERVING THE FOOD INDUSTRY SINCE 1951*

# STAINLESS STEEL COUNTERTOP STEAMER

Item: 44407

Model: FW-CN-1800



Authorized Dealer



**WARRANTY**  
PARTS AND LABOR



# FOOD EQUIPMENT

## STAINLESS STEEL COUNTERTOP STEAMER



### TECHNICAL DRAWING WITH DIMENSIONS

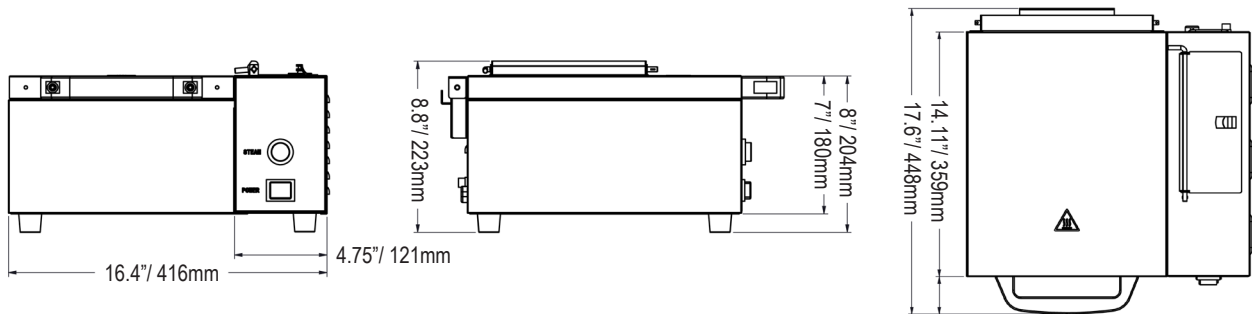

#### TECHNICAL SPECIFICATION

ITEM NUMBER	44407
MODEL	FW-CN-1800
CAPACITY	Half-size pan
POWER	1800 Watts
AMPS	15A
PRE-HEAT TIME	25 minutes
WATER RESERVOIR CAPACITY	3 QT / 2.8 L
WATER RESERVOIR DIMENSIONS	8.26" x 4.33" x 3.7" / 209.8 x 110 x 94 mm
ELECTRICAL	120V / 60Hz / 1Ph
NET DIMENSIONS (DWH)	17.6" x 16.4" x 8.8" / 447.8 x 416 x 223 mm
GROSS DIMENSIONS	19.88" x 18" x 10.43" / 505 x 457 x 265 mm
NET WEIGHT	36.8 lbs. / 17 kg
GROSS WEIGHT	41.9 lbs. / 19 kg

#### FEATURES

- Heavy-duty stainless steel construction
- Pre-heating time of 25 minutes
- 3QT (2.8L) large water tank
- Push button control
- Steam temperature up to 100°C/212°F
- Easy to use and clean

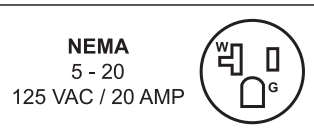

## OMCAN INC.

Telephone: 1-800-465-0234  
 Fax: (905) 607-0234  
 Email: sales@omcan.com  
 Website: www.omcan.com



Follow us to keep up to date with the latest news and offers

