



more durable, efficient, beautiful

4184 E. Conant St.
Long Beach, CA 90808
Tel. 310-900-1000
Fax. 310-900-1077
www.turboairinc.com

Project:	
Model #:	
Item #:	
Available W/H:	Qty:
Approval:	
AIA #:	SIS #:
CSI Section 11400	

Mega Top Unit - Drawers

Food Prep Tables
PRO Series

FEATURES & BENEFITS

- Self-Cleaning Condenser**
 The accumulation of dust in the condenser can cause the failure or breakdown of refrigerators. Refrigerators run normally until they reach a certain level of accumulation. At some point, when they are over the limit, their performance drops quickly resulting in damage to, or disposal of the stored products inside. The Self-Cleaning Condenser device keeps the condenser clean and prevents system failure by automatically brushing daily.
- Digital temperature control & monitor system**
 Keeps food products safe by maintaining constant temperatures. External digital display allows for easy monitoring.
- Hydrocarbon refrigerants (R-290)**
 With innovative and eco-friendly technology, Turbo Air brings you hydrocarbon refrigerators designed to meet DOE's Energy Conservation Standards in 2017 and to use EPA's SNAP Program approved HC refrigerants. Hydrocarbon refrigerants do not deplete the ozone layer and have very low contribution to global warming (ODP-0, GWP-3).
- Cold Bunker system**
 Our innovative forced air system allows cold air to flow all around the food pan area, covering not only underneath the pan, but also the front, top and the rear. This unique air flow creates a cold air-shield around the pan, which maintains the food temperature at under 41°F (NSF requirement) even when the lids are opened. In addition, the compartment isolates pans from the reach-in area to prevent food spillage.
- Stainless steel cabinet construction**
 The PRO series model boasts a stainless steel interior (Aluminum door liner) and a 22 gauge stainless steel exterior (galvanized steel bottom). It guarantees the utmost in cleanliness and long product life. The PRO series adds a touch of style to the most refined setting.
- High-density polyurethane insulation**
 The entire cabinet structure and solid doors are foamed-in-place using high density, CFC free polyurethane insulation.
- Easy removable hood & hood lid for cleaning**
- LED interior lighting & fan control**
- Spring assisted heavy duty gravity hinge**
- Insulated hood & hood lid**
- Refrigerator holds 33°F ~ 39°F for the best in food preservation**
- Built to maintain NSF standard temperatures in 100°F ambient**
- 9-1/2" deep, 1/2" thick high-density Polyethylene cutting board included with convenient side rail**

- PST-72-30-D2R-N: (Left) Drawer + (Right) Right hinged door
- PST-72-30-D2L-N: (Right) Drawer + (Left) Left hinged door

Model : PST-72-30-D2R-N PST-72-30-D2L-N



PST-72-30-D2R-N



PST-72-30-D2L-N

Patented Self-Cleaning Condenser



This product is equipped with a fine mesh filter to the front of the condenser to catch dust, and a rotating brush that moves up and down daily to remove excess buildup outward and away.

- Each top drawer accommodates up to 6" deep, one (1) full size with three (3) 1/6 size pans or two (2) 1/2 size with three (3) 1/6 size pans or three (3) 1/3 size with three (3) 1/6 size pans or nine (9) 1/6 size pans. And each bottom drawer accommodates up to 6" deep, one (1) full size pan or two (2) 1/3 size with two (2) 1/6 size pans or six (6) 1/6 size pans (drawer pans not included)**



Model	Swing Doors	Drawers	CU./FT.	#of Shelves	#of Pans	HP	AMPS	Crated Weight (lbs.)	L x D x H† (inches)
PST-72-30-D2R(L)-N	1	2	23	1	30	3/8	9.9	410	72 ⁵ / ₈ x 34 x 39 ⁵ / ₈

Mega Top Unit - Drawers

Food Prep Tables
PRO Series

Model : PST-72-30-D2R(L)-N

ELECTRICAL DATA	
Voltage	115/60/1
Plug Type	 NEMA 5-15P
Full Load Amperes	9.9
Compressor HP	3/8
Cord Length (ft.)	10
Refrigerant	R-290
DIMENSIONAL DATA	
Ext. Length Overall (in.)	72 ⁵ / ₈ (1846mm)
Ext. Depth Overall (in.)*	34 (864mm)
Ext. Height Overall (in.)†	39 ⁵ / ₈ (1007mm)
# of Doors	1
# of Drawers	2
# of Shelves	1
# of Pans	30
# of Hood	2
Net Capacity (cu. ft.)	23
Shelf Size (L x D) (in.)	33 ¹ / ₈ x 17
Net Weight (lbs.)	384
Gross Weight (lbs.)	410

Design and specifications subject to change without notice.
Actual shipping weight may differ due to extra packing materials for product protection.
* Depth does not include 3" for cutting board and 1-1/4" for rear spacers.
† Height does not include 4-1/2" for caster height.

■ WARRANTY : 5 Year Parts and Labor Warranty 7 Year Compressor Warranty

■ STANDARD FEATURES

- Anti-corrosion coated evaporator
- Self-contained system
- 4" dia. swivel casters with locks on the front set
- 1/6 size, 4" deep condiment pans included (top of cabinet)
- Door locks

■ OPTIONAL ACCESSORIES

- 1" caster, 1/2" diameter & 13 TPI: S28R813660 (non-brake)
- 2.5" caster, 1/2" diameter & 13 TPI: 30265H0100 (non-brake), 30265H0200 (w/ brake)
- 5" caster, 1/2" diameter & 13 TPI: M726500100 (non-brake), M726500200 (w/ brake)
- Leveling leg, 1/2" - 13 TPI x 1.54": LFM1213566
- 6" ABS plastic leg: 30221M0200
- 6" stainless steel leg: 30221M0600
- Removable food cover: RCT-48-18/72-30-L (Left), RCT-60-24/72-30-R (Right)
- Single overshelf, stainless steel, 72-13/16" W: TSOS-6S
- Double overshelf, stainless steel, 72-3/4" W: TSOS-6R-T

Ver.20251230

PLAN VIEW

(unit : inch)

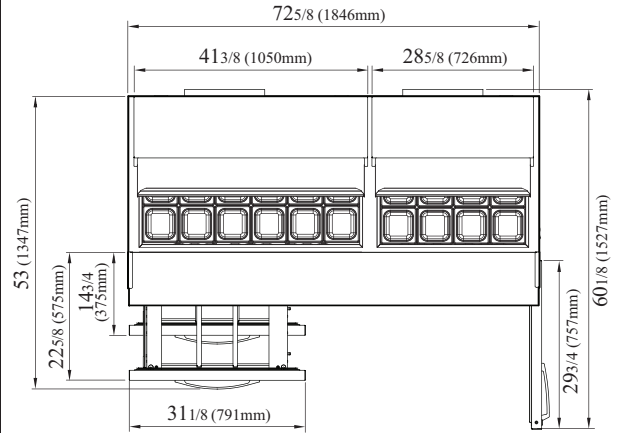

TOP VIEW

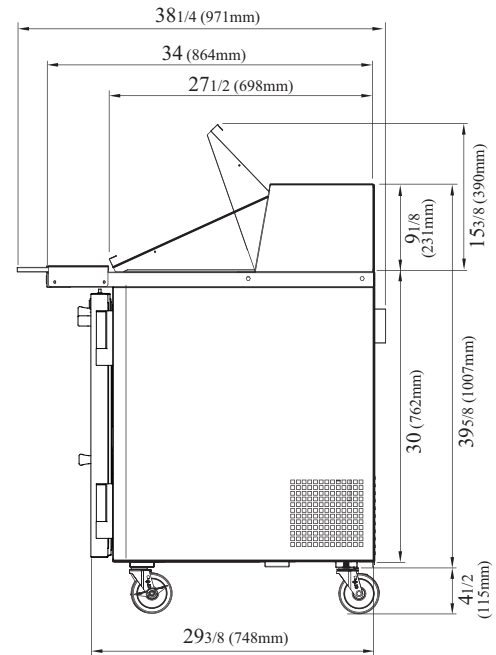

SIDE VIEW



- Turbo Air: 800-627-0032
- Bake Tech Innovation: 800-500-3519
- Warranty: 800-381-7770
- AC: 888-900-1002