

# SERVE-ALL™

## Mobile Food Station

### Serve Both Hot And Chilled Food Items In One Convenient Mobile Unit

#### Benefits

- Move your serving unit to where patrons congregate
- Heated wells accept standard food pans
- Welded stainless steel construction is durable and easy to clean

#### Features

- Insulated wells provide even concentration of heat and serving temperatures
- Seven quart soup well maintains recommended 140° F temperature
- Dry heat wells feature individual temperature controls
- Chilled drawers include eutectic bins for cold storage

#### Casters

- Non-marking cushion tread 5", all-swivel, two with brake



Model 6745



Model 6750



Chilled Storage Drawers



Utility Storage Drawers

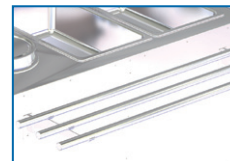

Optional Tray Rail



Optional Food Guard/Shelf

#### Specifications:

Shall be Lakeside Model \_\_\_\_\_ and shall feature a stainless steel top and exterior. Top shall have two or three each dry heated wells and one each heated soup well with individual controls. Heated wells shall be UL listed and shall accommodate standard food pans and UL listed soup well shall include a 7-quart insert with cover. Base cabinet shall feature two each utility storage drawers and two each chilled storage drawers with plastic eutectic 12" x 20" bins. Cabinet shall include end-mounted push handle and bottom corner bumpers. Unit shall be 220 VAC, 20 Amp, and shall include a 4-wire power supply cord with 14-30P plug. Casters shall be all-swivel, (2 each with brake), and shall have 5" (127 mm) non-marking wheels with rounded cushion tread non-marking wheels.

#### Model 6750

Shall include an open storage compartment with two each pair of adjustable removable stainless steel universal ledges.

Spec. # \_\_\_\_\_

AIA # \_\_\_\_\_

# SERVE-ALL™

## Mobile Food Station

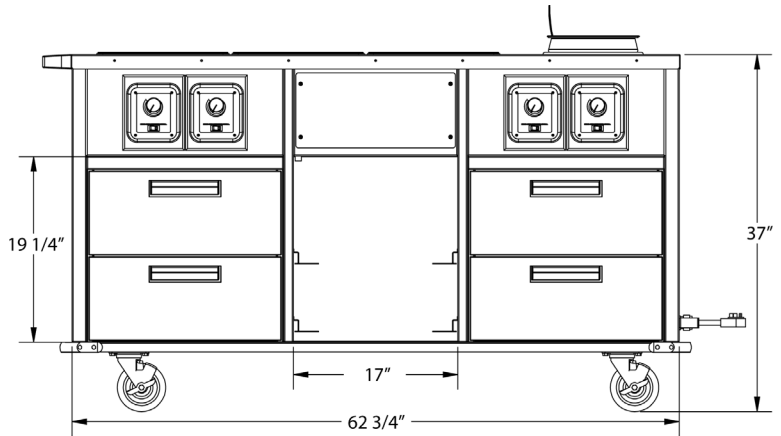
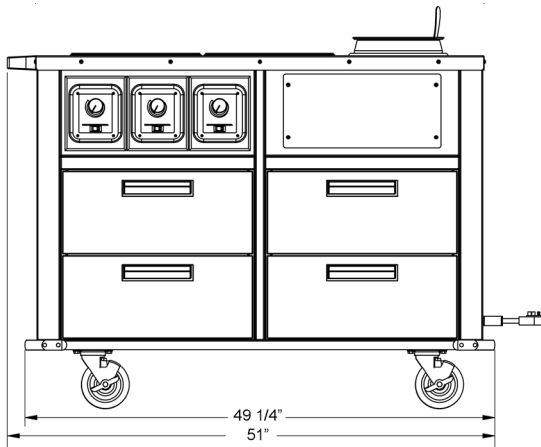
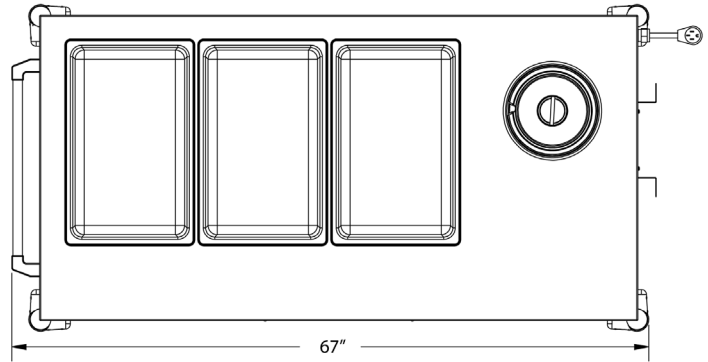
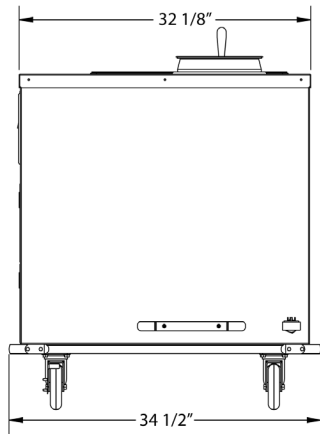

Spec. #

AIA #

### Product Information:

Model	Storage	Heated Wells	Overall Size			Case Weight
			W	L	H	
6745	2 ea. eutectic drawers 2 ea. utility drawers	2 ea. 12" x 20" (305 x 508) 1 ea. Soup	34½" (876)	51" 1295	37" 940)	350 (159)
6750	2 ea. eutectic drawers 2 ea. utility drawers 1 ea. open compartment	3 ea. 12" x 20" (305 x 508) 1 ea. Soup	34½" (876)	67" 1702	37" 940)	485 (220)

Measurements in ( ) denote metric millimeters, unless otherwise specified.

### Options:

- Additional 12" x 20" well in place of soup well
- 12" x 20" wells with drain
- Induction stove (208/220 VAC 20 amp) in place of 12" x 20" well
- Additional chilled drawers in place of utility drawers
- 3-rail fold-down tray slide
- Food guard with top serving shelf

### Electrical Specifications

#6745	220VAC	2000W
#6750	220VAC	2750W



Lakeside Manufacturing, Inc.

4900 West Electric Avenue • West Milwaukee, WI 53219 U.S.A.

800-558-8565 • 414-902-6400 • Fax 414-902-6446 • www.eLakeside.com