

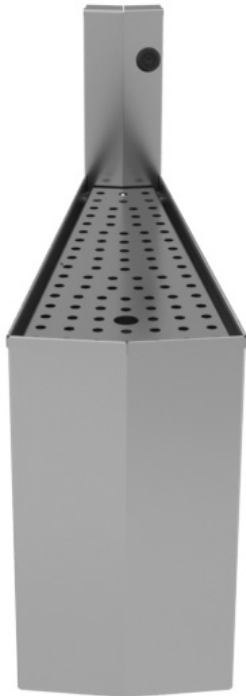

A family company manufacturing in the USA

www.glastender.com



COWA-15



Intertek

4004503

Conforms to ANSI/NSF STD 2

Project: _____	AIA# _____
Item #: _____ Qty: _____	SIS# _____
Model #: _____	

Corner Outside Wedge Drainboards

COW	COWA-15, COWA-30, COWA-45, COWA-60, COWA-75, COWB-15, COWB-30, COWB-45, COWB-60, COWB-75
------------	--

Standard Features

- All stainless steel
- Designed to mount between two adjacent pieces of Glastender underbar equipment (unless optional legs are used, see configurable options)
- Drain pan with separate perforated insert for better air circulation
- 1/4" radius work surface corners for easy cleaning

Configurable Options

- Leg set for one side mounting

Specifications

Drain

- 1/2" welded tailpiece drain

Materials

- 20 gauge stainless steel

To view underbar installation instructions: <https://www.glastender.com/support/documents/manuals/underbar-installation-instructions>

Cleaning & care instructions: <https://www.glastender.com/support/documents/manuals/general-cleaning-and-care-instructions-for-stainless-steel>

Glastender, Inc. • 5400 N Michigan Rd • Saginaw, MI • 48604-9780 989.752.4275 • 800.748.0423 • Fax 989.752.4444 www.glastender.com	Approval/Notes:
---	-----------------

Specifications subject to change without notice. For current specifications please visit our website.

Corner Outside Wedge Drainboards

Dimensional Information

"A" Depth-19" Deep
PLAN VIEWS

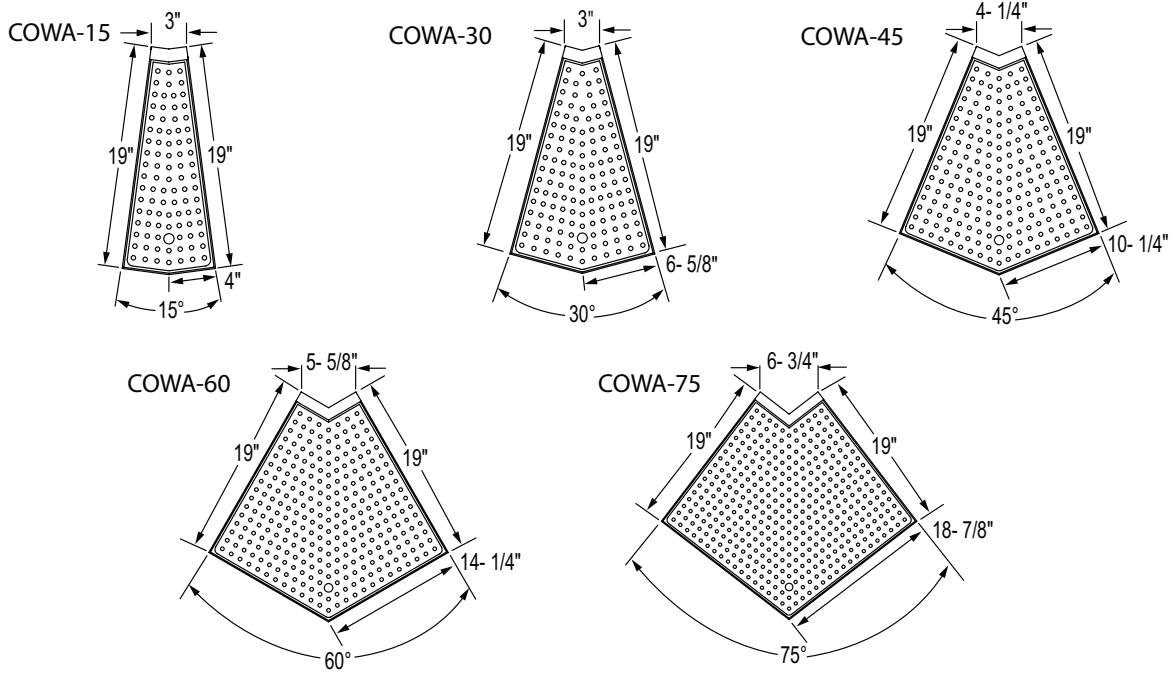

"B" Depth-24" Deep
PLAN VIEWS

