

DEAN®

GF14

VALUE GAS FRYER



GF14

Designed for versatile frying and dependable performance, GF fryers deliver consistent results across a wide range of menu items. With DEAN's trusted reliability and a spacious open frypot for easy cleaning, these fryers combine durability, efficiency, and great taste in every batch.

Consistent Heat, Built to Last: The Master Jet burner system features durable metal targets that create an expansive heat-transfer area, ensuring reliable and even heat distribution throughout the frypot. This advanced design delivers consistent cooking performance while standing up to the demands of high-volume kitchens.

Designed for Cleaner Oil & Easier Maintenance: The large cold zone and forward sloping bottom help collect and remove sediment from the frypot to safeguard oil quality and support routine frypot cleaning.

Open Pot, Clean Results: The open pot design provides an unobstructed heated area, allowing operators to easily monitor sediment buildup for better oil management. Heated from the outside, it offers quick access for cleaning and consistent frying performance, though with a smaller sediment zone than tube-style fryers.

Project _____

Item _____

Quantity _____ CSI Section 11400 _____

Approval _____ Date _____

MODELS

GF14

CONTROLLERS

Millivolt (standard)

SPECIFICATIONS	
OIL CAPACITY	40-lbs. (20 liters) PER FRYPOT
FRYING AREA	12" x 15" x 4" (30.5 x 38.1 x 10.2 CM) PER FRYPOT
POT TYPE	Open Pot
GAS TYPE	Natural Gas Propane Mix
POWER	100,000 BTU/HR (CE - 27 KW NET) PER FRYPOT
STANDARD FEATURES	<ul style="list-style-type: none"> ▪ Deep cold zone ▪ Durable temperature probe ▪ No electric connection required ▪ 1-1/4" (3.2 cm) IPS ball-type drain valve ▪ Combination gas valve with regulator ▪ Stainless steel frypot and door with aluminized cabinet sides
STANDARD ACCESSORIES	<ul style="list-style-type: none"> ▪ (2) Twin baskets PER FRYPOT ▪ Wire basket hanger ▪ Basket support rack ▪ Casters

Liter conversions are for liquid shortening @ 70° F



REVISED SPRING 2026

Frymaster®

318-865-1711
1-800-221-4583
info@frymaster.com

8700 Line Avenue
Shreveport, LA 71106-6800, USA
FRYMASTER.COM

WELBILT®
an All Group Company

DIMENSIONS	MODEL	OIL CAPACITY PER FRYPOT	OVERALL SIZE			DRAIN HEIGHT
			WIDTH	DEPTH	HEIGHT	
	GF14	40-lbs. (20 liters)	15.63" (39.7 cm)	30.88" (78.4 cm)	41.13" (104.4 cm)	13" (33.0 cm)

CRATED	MODEL	WEIGHT	WIDTH	DEPTH	HEIGHT	CU. FT.	CLASS
	GF14	115-lbs. (52 kg)	21" (53.3 cm)	35" (88.9 cm)	47" (119.4 cm)	20	85

Information is APPROXIMATE and may vary at time of shipment due to options/add-ons

GAS REQ.	GAS TYPE	INC. GAS PRESSURE	POWER
	NATURAL GAS	6" W.C.—14" W.C.	
LIQUID PROPANE	9" W.C.—14" W.C.		
MIXED GAS	11" W.C.—14" W.C.		

GAS CONNECTION	
FRYPOTS	SIZE NPT
1	(1) 3/4"

CLEARANCE INFORMATION

Front: 36" (91.4 cm) for servicing and proper operation.

Sides & Rear: 6" (15.2 cm) from any combustible material.

VENTILATION REQUIREMENTS

When installing any fryer, NFPA Standard No. 96 must be strictly followed.

NOTES

- **DO NOT CURB MOUNT**
- Split pots and basket lifts not available.

HOW TO SPECIFY

Electric or gas, gas type (if applicable), pot type, energy output, oil capacity, number of frypots, controller, filtration type, and optional feature(s).

- **Elevation:** Must specify elevation if between 2,000 – 6,000 ft. (Fryer may not perform at optimum levels above 6,000 ft.)

WARRANTY

Frypot & Assembly

1st year: Parts + Labor

2nd - 5th years: Parts Only

All Other Parts

1 year: Parts + Labor

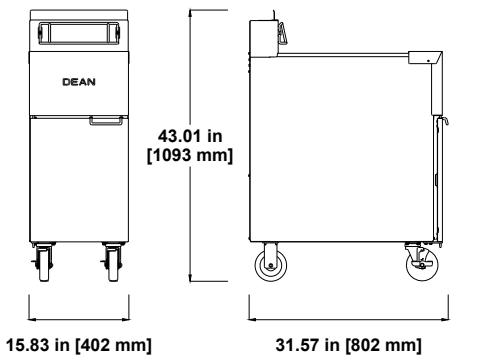

Frymaster reserves the right to make changes to the design or specifications without prior notice.

REVISED SPRING 2026