



DS24
with stainless steel door and top



Intertek

4004503

Conforms to NSF/ANSI STD 2

Project: _____	AIA# _____
Item #: _____ Qty: _____	SIS# _____
Model #: _____	

Dry Storage Cabinets

DS24, DS40, DS48, DS60,
DS72, DS80, DS96

Configurable Options

Door Style & Finish:

- Black vinyl-clad
- Stainless steel
- Jeweled stainless
- Laminated
- Unlaminated

Top Style:

- No finished top
- Stainless top

Left and Right Side Finish:

- Black vinyl-clad
- Stainless steel

Door Hinge Location (*specify for each door*):

- Left or Right

Door Handle:

- Signature
- Pull-tab
- Tube

Standard Features

- Locking door(s)
- Eco-friendly, foamed-in-place insulated sides and door (excluding DS24 sides)
- Stainless steel sub top (excluding DS24, which has an open top)
- Black vinyl-clad steel exterior front and sides
- Two adjustable, coated-wire shelves per door section (DS24 excluded)
- DS24 includes 16 gauge galvanized shelves

Underbar installation instructions: <https://www.glastender.com/support/documents/manuals/underbar-installation-instructions>

Cleaning & care instructions: <https://www.glastender.com/support/documents/manuals/general-cleaning-and-care-instructions-for-stainless-steel>

Glastender, Inc. • 5400 N Michigan Rd • Saginaw, MI • 48604-9780 989.752.4275 • 800.748.0423 • Fax 989.752.4444 www.glastender.com	Approval/Notes:
<small>Specifications subject to change without notice. For current specifications please visit our website.</small>	

Dry Storage Cabinet

Specifications

		DS24	DS40	DS48	DS60	DS72	DS80	DS96
Dimensions	Length	24"	40"	48"	60"	72"	80"	96"
	Number of Sections	1	2	2	3	3	4	4
	Door Opening	21"	16"	20"	16"	20"	16"	20"
Weight Bearing Capacity		Countertops and other accessories should not exceed 500 pounds per door						

Materials

- Stainless steel parts include: exterior sub-top (DS24 excluded), interior, front of cabinet, hinges, hinge and lock brackets, and optional legs
- Black vinyl-clad steel parts include: standard sides, doors and compressor cover
- Galvanized steel parts: interior



5400 N Michigan Rd • Saginaw, MI • 48604-9780
989.752.4275 • 800.748.0423 • Fax 989.752.4444
www.glastender.com

Dry Storage Cabinets

Drawings

PLAN VIEW

21" DOOR OPENING LENGTH (SEE TABLE)

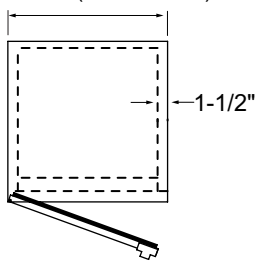

16" DOOR OPENING LENGTH (SEE TABLE)

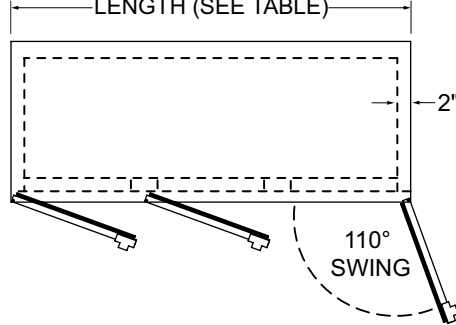

20" DOOR OPENING LENGTH (SEE TABLE)

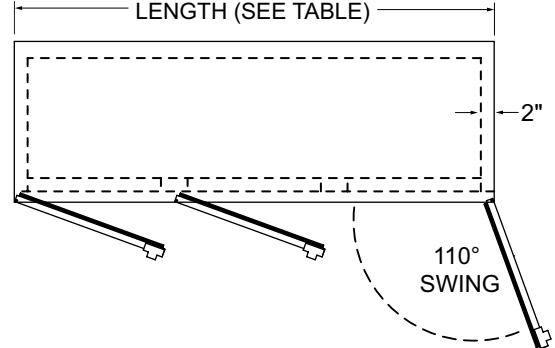

FRONT VIEW

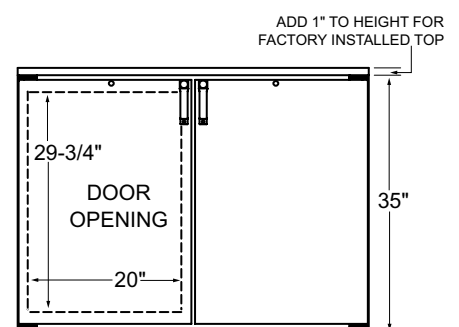
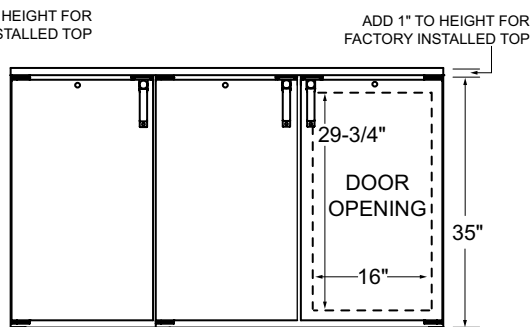
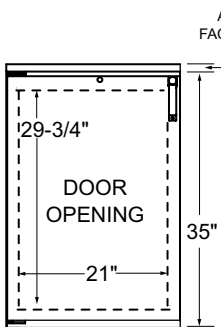

SIDE VIEWS

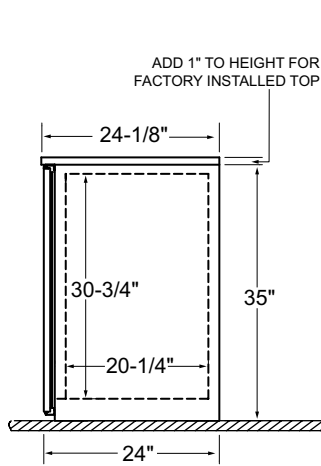

STANDARD CABINET

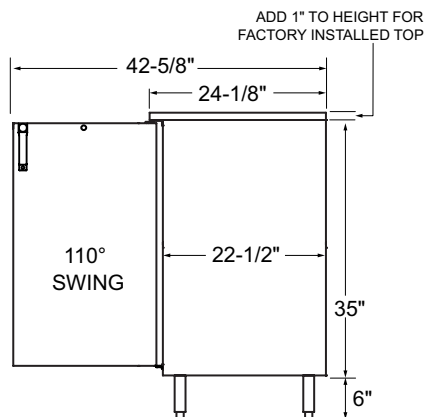

SHOWN WITH OPTIONAL 6" LEGS

