



LuminIce® II Virus and Bacteria Inhibitor

LuminIce® II Growth Inhibitor

Factory Built-in Option

Add "X" to suffix of Indigo NXT model number. (Available on selected models)

K-00464 Upgrade Kit

(for Indigo NXT: iF0300- iT1200, QQ iF0600C to iT1200C)

K-00465 Upgrade Kit

(for Indigo NXT: iT1500 & iT1900, IB's and Duals)

K-00519 Upgrade Kit

(for NEO: U-Series Undercounter ice machines)



The sanitization icon on Indigo NXT shines blue for working, Red for bulb replacement.

Standard Features

- **Defends Against Viruses and Bacteria** – uses a uniquely designed 254 nm UVC germicidal class light and 185 nm UVV light to create COP (Cold Oxygen Plasma)
- **Reduced Yeast and Bacteria Growth** – proven by independent lab testing to inhibit the growth of yeast and bacteria for a cleaner foodzone.
- **Easier Cleaning** – reduced slime build up speeds the regularly scheduled cleaning process.
- **Fully Integrated Design** – device mounts inside the Indigo NXT ice machine, powered by the board and is fully integrated with the easyTouch display
- **Easy to Use** - no chemicals to add or maintain. Only a simple UV bulb change is recommended once a year to maintain effectiveness.

Note: Indigo NXT provides a sanitization icon in the easyTouch display that changes from blue to red when its time to change the bulb.

Note : Use kit K00474 kit to convert LuminIce II kits (K00450 and K00451) for Indigo to work with Indigo NXT.

Warranty

- 3-year parts and labor (excludes bulb)
- UV bulb warranty 90 days.

The LuminIce II Virus and Bacteria Inhibitor, works 24/7, defending against microorganisms whether you are making ice or not. A unique design uses a germicidal class 254 nm UVC light to sterilize air that passes by and 185 nm UVV light that creates photo plasma gas to inhibit the growth of viruses, bacteria and fungi.

Foodservice operations can often be in challenging environments where it is difficult to prevent yeast, mold and other micro-organism contamination. With LuminIce II, testing has shown that ice machine foodzones are noticeably cleaner after only 2-1/2 months of usage.



The LuminIce II device runs quietly 24 hours a day keeping your ice machine cleaner and helping to relieve the stress and pain of frequent cleanings. Reduced cleanings ultimately saves labor time, cost, and machine downtime during the cleaning process.

Electric

Electricity drawn directly from ice machine.

Bulb Replacement

To retain maximum effectiveness, annual replacement of the internal UV bulb is recommended. UV bulb shelf life is 3 years from date of manufacture. Use bulb K00454 or K00428 for Indigo ice machines built after July 1, 2015.

K00425 for machines before July 1, 2015.





How LuminIce II Works

Air from behind the evaporator is passes by a germicidal class 254 nm UVC light and is sterilized. Then a 185 nm UVV light and acts on the oxygen and water vapor in the air stream as it passes by the bulb to create photo plasma. Cold Oxygen Plasma is a gas that is ionized by UVV light containing ions, free electrons, hydroxyl radicals and ozone. Each of which is highly reactive with the microorganisms it encounters in the food zone. This active air is continually recirculated within the Foodzone inhibiting virus and bacteria growth.

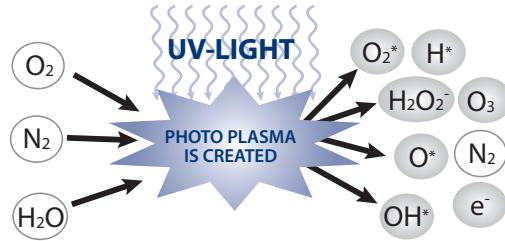

LuminIce II (Internal Mounting)

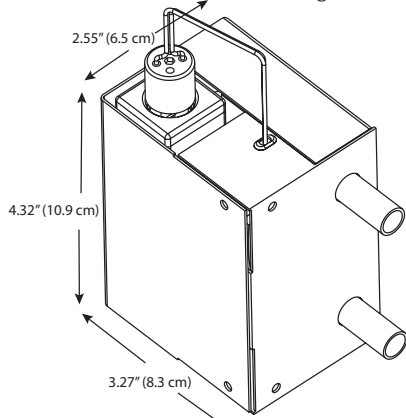

LuminIce II UV Bulb

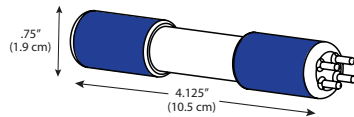

Standard bulb replacement use K00454 with LuminIce II

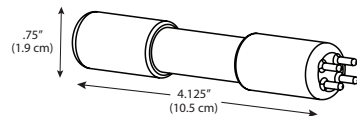

Use High intensity bulb kit K00528 used for large machines or challenging conditions.

LuminIce II Models / Replacement Bulb

Model	Description
X	Built in factory installed LuminIce II Growth Inhibitor is available on selected models by adding an "X" prefix to the end of the Indigo NXT model number. (Check the most current price list for availability. All other Indigo NXT can be fitted with the after market kits).
K00519	LuminIce II kit for NEO undercounters UF0140 to UF0310 (Replaces kit K00452).
K00464	LuminIce II kit for small-medium Indigo NXT models: IT0300, IT0420, IT0450, IT0500, IF0600, IT0750, IF0900, IT1200. Quite Cube models IF0600C, IF0900C and IT1200C.
K00465	LuminIce II kit for indigo NXT models: ("48" iT1500, iT1900) ("IB's" iBF0620C, iBF0820C, iBT1020C) ("Duals" IF1400C, IF1800C).
K00474	Wire harness to allow for the K00451 and K00452 to work with the appropriate Indigo NXT model
K00454	Replacement LuminIce II bulb for Indigo NXT and Indigo only for units built after July 1, 2015-(bulb with blue end caps)
K00528	Replacement Higher intensity LuminIce II bulb for Indigo NXT or Indigo units built after July 1, 2015. Use in larger machines or difficult environments.
K00425	Replacement bulb, for first generation LuminIce only for Indigo units built before July 1, 2015

Cleaner Ice Machine Foodzones

Confirmed by Independent Testing Lab

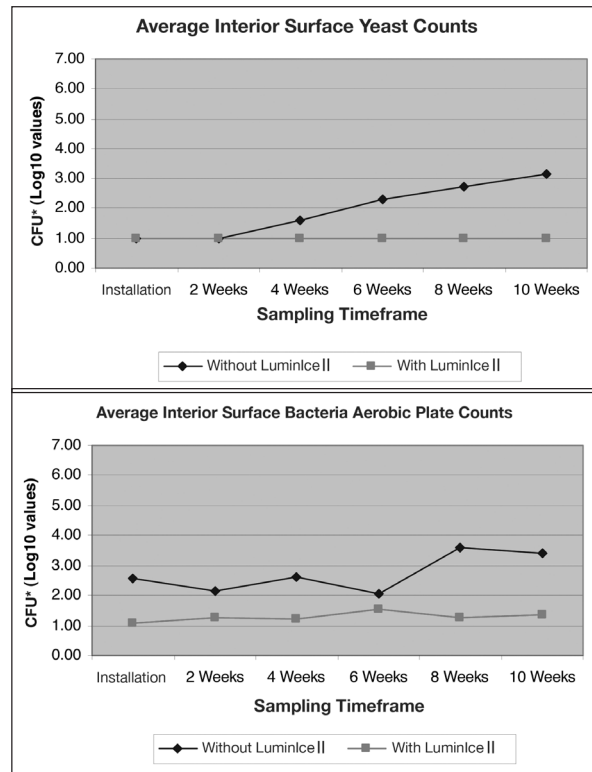

*Average foodzone Colony Forming Units (CFU's) plotted over time from date of installation.

Welbilt reserves the right to make changes to the design or specifications without prior notice.