

Frymaster®

1814G

OIL-CONSERVING GAS FRYERS



21814GF

The Frymaster 1814G is engineered for high-volume kitchens that demand efficiency, consistency, and space optimization. With a 63-lbs. frypot and an expansive 18" x 14" cooking area, it delivers the output of larger fryers while conserving oil, energy, and floor space. Its advanced heating system and precise temperature controls ensure superior food quality and extended oil life, making it a smart choice for operators focused on performance and sustainability.

More Frying Power, Less Oil Waste: The 63-lbs. frypot is optimized to create an 18" x 14" frying area that accommodates 3 baskets of product. Compared to a standard 50-lb fryer configuration, achieving the same output would require an additional 75 lbs. of oil—highlighting the 1814's superior oil utilization and throughput efficiency.

Maximize Output, Minimize Space: Two 1814 frypots deliver the same output as three standard 50-lbs. frypots, while using 10–15% less hood space—boosting productivity without increasing footprint.

Energy Efficiency that Translates to Savings: Frymaster's Thermo-Tube design provides an additional 2" of tube height and 36% more heat transfer surface area. This reduces the heat per square inch on the oil by 22%, for more efficient heat transfer and longer lasting oil life.

Project _____

Item _____

Quantity _____ CSI Section 11400 _____

Approval _____ Date _____

MODELS

11814G
(no built-in filtration)

11814GF

21814GF

31814GF

OPTIONS / ADD-ONS

Basket lifts

Spreader cabinet

External oil discharge
(front or rear)

Bulk oil

CONTROLLERS

Digital Timer

CM3.5

Lane (standard)

3000

SPECIFICATIONS	
OIL CAPACITY	63-lbs. (31 liters) PER FRYPOT
FRYING AREA	18" x 14" x 3.75" (45.7 x 35.6 x 9.5 CM) PER FRYPOT
POT TYPE	Tube
GAS TYPE	Natural Gas Propane Mix
PLUG	NEMA 5-15P
POWER	119,000 BTU/HR (33.7 KW NET) PER FRYPOT
STANDARD FEATURES	<ul style="list-style-type: none"> Thermo-Tube heat-transfer design Wide cold zone RTD 1° compensating temperature probe Built-in, manual filtration 8 GPM pump Drain safety switch (for all filter models) Combination gas valve with regulator Electronic ignition Stainless steel frypot, door, and sides
STANDARD ACCESSORIES	<ul style="list-style-type: none"> (3) Twin baskets PER FRYPOT Basket hanger(s) Basket support rack(s) Filter starter kit (for all filter models) 6"-7" (15–17 cm) adjustable steel legs (11814G model) Casters (all filter models)

Liter conversions are for liquid shortening @ 70° F



REVISED SPRING 2026

Frymaster®

318-865-1711
1-800-221-4583
info@frymaster.com

8700 Line Avenue
Shreveport, LA 71106-6800, USA
FRYMASTER.COM



DIMENSIONS	MODEL	OIL CAPACITY PER FRYPOT	OVERALL SIZE			DRAIN HEIGHT
			WIDTH	DEPTH	HEIGHT	
	11814G	63-lbs. (31 liters)	20.4" (51.8 cm)	31.1" (78.9 cm)	47.6" (121.0 cm)	17.5" (44.5 cm)
	11814GF		40.4" (102.6 cm)	34.2" (86.9 cm)		11.5" (29.2 cm)
	21814GF				60.4" (153.4 cm)	
	31814GF					

CRATED	MODEL	WEIGHT	WIDTH	DEPTH	HEIGHT	CU. FT.	CLASS
11814GF	390-lbs. (177 kg)						
	21814GF	645-lbs. (293 kg)	52.5" (133.4 cm)	77.5			
	31814GF	900-lbs. (408 kg)	65.5" (166.4 cm)				

Information is APPROXIMATE and may vary at time of shipment due to options/add-ons

GAS REQ.	GAS TYPE		INC. GAS PRESSURE	POWER	
	NATURAL GAS		6" W.C.—14" W.C.	119,000 BTU/HR (CE - 33.7 KW NET) PER FRYPOT	
	LIQUID PROPANE		9" W.C.—14" W.C.		

POWER	REGION	CONTROLS PER FRYPOT	FILTER PER FRYPOT	BASKET LIFTS PER FRYPOT
	DOMESTIC	1 A	8 A	3 A
	EXPORT	1 A	4 A	2 A

Plug is optional on all units shipped with a cord. Canada is an exception; and cord, where available, must have a plug attached.

Cord length and gauge as well as plug type and style available vary depending upon fryer model, voltage, kW, destination, and customer specifications. Consult local codes or contact factory.

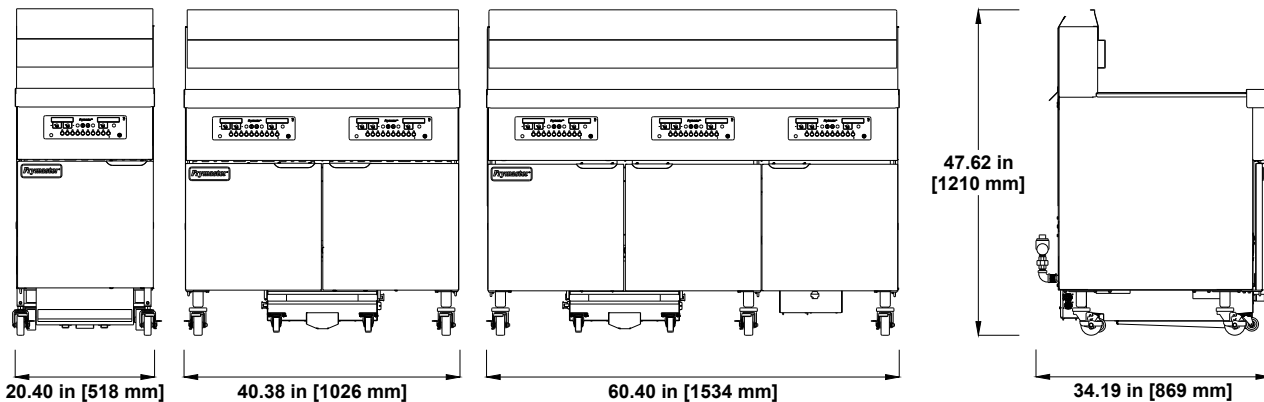
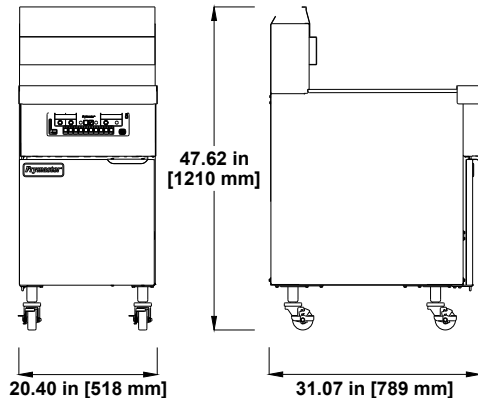

GAS CONNECTION	
FRYPOTS	SIZE NPT
1	(1) 3/4"
2-3	(1) 1"

For Germany 3/4" NPT Per Frypot

CLEARANCE INFORMATION

Front: 36" (91.4 cm) for servicing and proper operation.

Sides & Rear: 6" (15.2 cm) from any combustible material.

VENTILATION REQUIREMENTS

When installing any fryer, NFPA Standard No. 96 must be strictly followed.

NOTES

- **DO NOT CURB MOUNT**
- Split pots and basket lifts not available.

HOW TO SPECIFY

Electric or gas, gas type (if applicable), pot type, energy output, oil capacity, number of frypots, controller, filtration type, and optional feature(s).

- **Elevation:** Must specify elevation if between 2,000 – 6,000 ft. (Fryer may not perform at optimum levels above 6,000 ft.)

WARRANTY

Frypot

1st year: Parts + Labor

2nd - 10th years: Parts Only

All Other Parts

1 year: Parts + Labor