



Item: \_\_\_\_\_

Quantity: \_\_\_\_\_

Project: \_\_\_\_\_

**Snack Thermostatic Griddle**

## Royal Series

Models:  RSTG-12     RSTG-18     RSTG-24     RSTG-36     RSTG-48



RSTG-36

Gas Type:  Natural     LP

Elevation (if above 2000 ft.): \_\_\_\_\_

### Standard Features

- 18" cooking depth
- 11" high, Low Profile
- Large 1½ gallon capacity S/S grease can
- Compact heavy gauge chassis for long life
- 18" cooking surface depth
- Stainless steel sides and front valve cover
- Double wall panels for cooler sides
- Aeration panels between the burners for added efficiency
- Stainless Steel "U" shaped burner every 12" rated at 20,000 BTU/hr each
- Energy saving thermostat is adjustable from 150°-450° F
- 3/4" thick griddle plate with polished cooking surface
- Thermo control to operate every burner
- 4" wide S/S grease trough with large drain opening for easy cleaning
- Stainless steel tubing for burners and pilots
- 4" high adjustable heavy duty legs included

### Options and Accessories

- 1" thick griddle plate
- Grooved griddle (specify width: \_\_\_\_\_")
- Chrome griddle plate
- Stainless Steel Equipment Stand
  - Knock Down     All Welded
- Size
  - 12"     18"     24"     30"     36"     48"     60"     72"
  - 5" swivel casters (set of four - 2 locking)
  - 5" swivel casters (set of four - 2 locking) (60" and 72" stands)



**LIMITED WARRANTY, TWO YEAR PARTS AND ONE YEAR LABOR**

# Snack Thermostatic Griddle

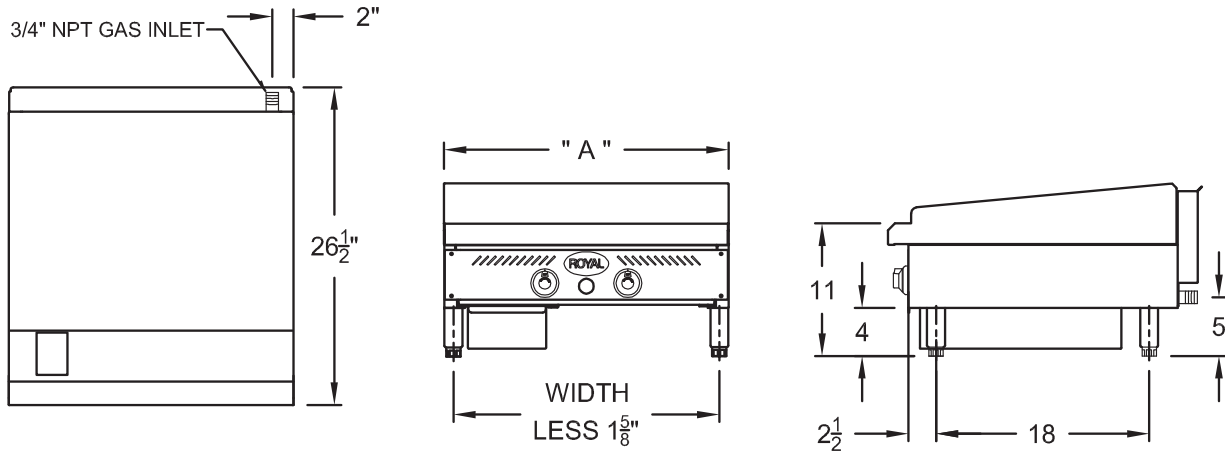

Model Number	Width (A)	Number of Thermostats	Number of Burners	Total BTU	Ship Weight
RSTG-12	12"	1	1	20,000	125 lbs.
RSTG-18	18"	1	1	20,000	148 lbs.
RSTG-24	24"	2	2	40,000	180 lbs.
RSTG-36	36"	3	3	60,000	250 lbs.
RSTG-48	48"	4	4	80,000	315 lbs.

**Notes:**

**Gas Connection:**

3/4" NPT on the right hand rear of the appliance.

The pressure regulator (supplied) is to be connected by the installer.

Specify type of gas and altitude, if over 2,000 feet, when ordering.

**Gas Pressure:**

5" W.C.	Natural Gas
10" W.C.	Propane

**Clearances:**

	Combustible	Non-Combustible
Rear	6"	0"
Sides	4"	0"

Due to continuing product development to ensure best possible performance, these specifications are subject to change without prior notification.

**Royal Range of California**  
 3245 Corridor Dr. • Eastvale, CA 91752 • (800) 769-2414 • (951) 360-1600  
 Fax: (951) 360-7500 • www.royalranges.com • sales@royalranges.com