

Note that the red model (Sense7) is obsolete.
It is only the stainless steel model (Sense7Z) that is active.



Original instructions

Sense7-series

Non-contact coded safety switch



Read and understand this document

Please read and understand this document before using the products. Please consult your ABB JOKAB SAFETY representative if you have any questions or comments.

WARRANTY

ABB Jokab Safety's exclusive warranty is that the products are free from defects in materials and workmanship for a period of one year (or other period if specified) from date of sale by ABB JOKAB SAFETY.

ABB JOKAB SAFETY MAKES NO WARRANTY OR REPRESENTATION, EXPRESSED OR IMPLIED, REGARDING NON-INFRINGEMENT, MERCHANTABILITY, OR FITNESS FOR PARTICULAR PURPOSE OF THE PRODUCTS, ANY BUYER OR USER ACKNOWLEDGES THAT THE BUYER OR USER ALONE HAS DETERMINED THAT THE PRODUCTS WILL SUITABLY MEET THE REQUIREMENTS OR THEIR INTENDED USE. ABB JOKAB SAFETY DISCLAIMS ALL OTHER WARRANTIES, EXPRESSED OR IMPLIED.

LIMITATIONS OF LIABILITY

ABB JOKAB SAFETY SHALL NOT BE RESPONSIBLE FOR SPECIAL, INDIRECT, OR CONSEQUENTIAL DAMAGES, LOSS OF PROFITS OR COMMERCIAL LOSS IN ANY WAY CONNECTED WITH THE PRODUCTS, WHETHER SUCH CLAIM IS BASED ON CONTRACT, WARRANTY, NEGLIGENCE, OR STRICT LIABILITY.

In no event shall responsibility of ABB JOKAB SAFETY for any act exceed the individual price of the product on which liability asserted.

IN NO EVENT SHALL ABB JOKAB SAFETY BE RESPONSIBLE FOR WARRANTY, REPAIR, OR OTHER CLAIMS REGARDING THE PRODUCTS UNLESS ABB JOKAB SAFETY'S ANALYSIS CONFIRMS THAT THE PRODUCTS WERE PROPERLY HANDLED, STORED, INSTALLED, AND MAINTAINED AND NOT SUBJECT TO ABUSE, MISUSE, OR INAPPROPRIATE MODIFICATION OR REPAIR.

SUITABILITY FOR USE

ABB JOKAB SAFETY shall not be responsible for conformity with any standards, codes, or regulations that apply to the combination of products in the customer's application or use of the product. At the customer's request, ABB JOKAB SAFETY will provide applicable third party certification documents identifying ratings and limitations of use that apply to the products. This information by itself is not sufficient for a complete determination of the suitability of the products in combination with the end product, machine, system, or other application or use.

The following are some examples of applications for which particular attention must be given. This is not intended to be an exhaustive list of all possible uses of the products, nor is it intended to imply that the uses listed may be suitable for the products:

Outdoor use, uses involving potential chemical contamination or electrical interference, or conditions or uses not described in this document.

Nuclear energy control systems, combustion systems, railroad systems, aviation systems, medical equipment, amusement machines, vehicles, and installations subject to separate industry or government regulations.

Systems, machines, and equipment that could present a risk to life or property.

Please know and observe all prohibitions of use applicable to the products.

NEVER USE THE PRODUCTS FOR AN APPLICATION INVOLVING SERIOUS RISK TO LIFE OR PROPERTY WITHOUT ENSURING THAT THE SYSTEM AS A WHOLE HAS BEEN DESIGNED TO ADDRESS THE RISKS, AND THAT THE ABB JOKAB SAFETY PRODUCT IS PROPERLY RATED AND INSTALLED FOR THE INTENDED USE WITHIN THE OVERALL EQUIPMENT OR SYSTEM.

PERFORMANCE DATA

While every effort has been taken to ensure the accuracy of the information contained in this manual ABB JOKAB SAFETY cannot accept responsibility for errors or omissions and reserves the right to make changes and improvements without notice. Performance data given in this document is provided as a guide for the user in determining suitability and does not constitute a warranty. It may represent the result of ABB JOKAB SAFETY'S test conditions, and the users must correlate it to actual application requirements. Actual performance is subject to the ABB JOKAB SAFETY Warranty and Limitations of Liability.

Table of Contents

1	Introduction	4
	Scope	4
	Audience	4
	Prerequisites	4
	Special notes	4
2	Overview	5
	General description.....	5
	Safety regulations	5
	Function description.....	5
3	Connections	6
	Connection.....	6
	Cable configurations	6
	Pin configurations	6
4	Installation and maintenance	7
	Installation and maintenance	7
	Maintenance	7
	Minimum safety distance	8
5	Application examples	9
6	Model overview	11
	Accessories.....	11
	Dimensions	11
7	Technical data	12
8	EC Declaration of conformity	14

1 Introduction

Scope

The purpose of these instructions is to describe the non-contact coded safety switch Sense7-series, and to provide the necessary information required for assembly, installation, operations, checks and adjustments after installation, and maintenance. The instructions also include information necessary to connect Sense7 to a safety circuit.

Audience

This document is intended for authorized installation personnel.

Prerequisites

It is assumed that the reader of this document has knowledge of the following:

- Basic knowledge of ABB Jokab Safety products.
- Knowledge of safety devices and safety locks.
- Knowledge of machine safety.

Special notes

Pay attention to the following special notes in the document:

 **Warning!** Danger of severe personal injury!
An instruction or procedure which, if not carried out correctly, may result in injury to the technician or other personnel.

Caution! Danger of damage to the equipment!
An instruction or procedure which, if not carried out correctly, may damage the equipment.

NB: Notes are used to provide important or explanatory information.

2 Overview

General description

The coded non-contact switches Sense7 are designed to provide position interlock detection for moving guards. They are designed to fit the leading edge of sliding, hinged or lift off machine guards. The actuator is fitted to the moving part of the guard, and is aligned to the switch, placed on the frame of the guard. Its design makes it advantageous to operate in environments that require the highest level of safety.

Safety regulations

 **Warning!** Carefully read through this entire manual before using the device.

The devices shall be installed by a trained electrician following the Safety regulations, standards and the Machine directive.

Failure to comply with instructions, operation that is not in accordance with the use prescribed in these instructions, improper installation or handling of the device can affect the safety of people and the plant.

For installation and prescribed use of the product, the special notes in the instructions must be carefully observed and the technical standards relevant to the application must be considered.

In case of failure to comply with the instructions or standards, especially when tampering with and/or modifying the product, any liability is excluded.

Function description

The magnetic switch is small in size, which makes it easy to position and hide on gates and hatches. Sense7 is resistant to both dirt and water, and has no dust collecting cavities, which make it useful in environments where hygiene is paramount. The non-contact coded safety switch has a long working life since no mechanical contact is necessary for operation. The Sense7 has 2NC and 1NO contacts and a sensing distance to the actuator of 14mm. It has a high tolerance to misalignment. Actuator is always delivered with the non-contact switch.

Depending on the environment where the switch will be used, different material can be chosen on the Sense7. The basic version is in a full plastic body (polyester). In harsh applications as for food processing and chemical industry there is a Sense7Z with a total rugged stainless steel 316 body. Both versions have an enclosure protection up to IP69K and can be high pressure hosed with detergent at high temperature.

 **Warning!** Application consideration must be given to the fixing of the actuator which has to be in a way that prevents disassembly by easy means.

3 Connections

See Chapter Installation and Maintenance for more information regarding installation.

Connection

For all ABB switches the NC circuits are closed when the guard is closed and the actuator present.

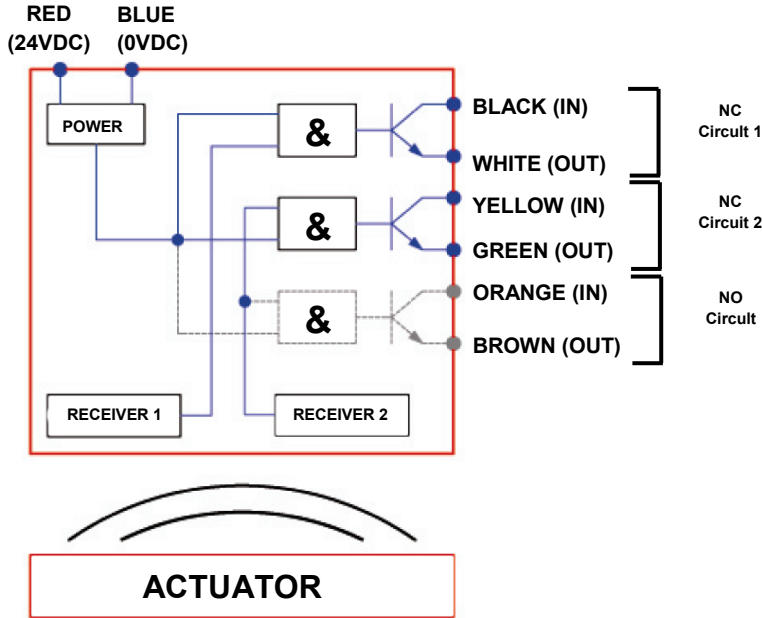

Cable configurations

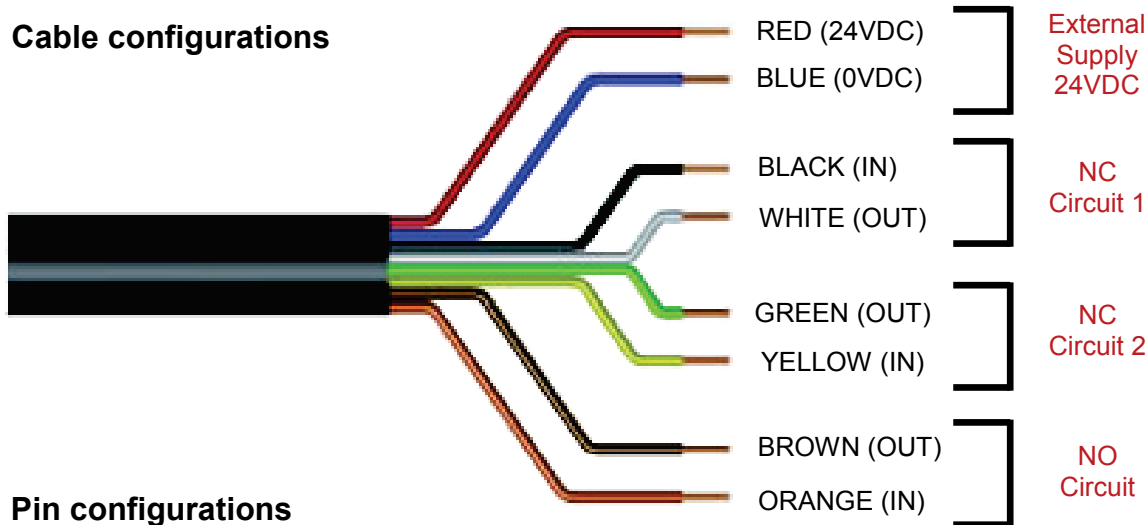

Pin configurations

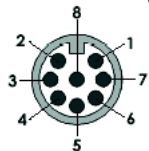

Connection colours:
(Important: The NC1 and NC2 Outputs are polarity sensitive).

Quick Connect (QC) M12 8 way Male Plug (Pin view from switch)	Flying Lead Colours	Circuit (Actuator present)	Output Types Solid State
8	Orange	Auxiliary (NO)	200mA Max. 24Vdc
5	Brown	Auxiliary (NO)	
4	Yellow	NC 2 +ve	200mA Max. 24Vdc
6	Green	NC 2 -ve	
7	Black	NC 1 +ve	200mA Max. 24Vdc
1	White	NC 1 -ve	
2	Red	Supply +24Vdc	+/- 10%
3	Blue	Supply 0 Vdc	

4 Installation and maintenance

Installation and maintenance

1. The installation of all ABB Jokab Safety interlock switches must be done in accordance with a risk assessment for the individual application. Installation must only be carried out by competent personnel and in accordance with these instructions.
2. The use of a safety relay is required for monitoring coded switches. These relays monitor 2 redundant circuits as per ISO13849-1 for up to PL e / Category 4 protection. Coded non-contact switches are designed to operate with most dual channel safety relays to satisfy IEC 60947-5-3 PDF-S.
3. M4 mounting bolts must be used to fix the switches. Tightening torque for mounting bolts to ensure reliable fixing is 1.0 Nm.

Installation on ferrous materials may reduce the sensing distance.

The recommended setting gap is 5 mm. The Safety switch must not be used as a mechanical stop or be adjusted by striking with a hammer.

The actuator must not be allowed to strike the switch. Do not mount adjacent switches or actuators closer than 30mm. Typical misalignment tolerance after setting is 5 mm.

4. After installation always check each switch function by opening and closing each guard individually in turn and ensuring that the Green LED on the switch and the LED's on the safety relay are illuminated when the switch is closed and are extinguished when the switch is open.
5. Check that the machine stops and cannot be re/started when each switch is open.

 **Warning!** All the safety functions must be tested before starting up the system.

Maintenance

Monthly: Check alignment of actuator and look for signs of mechanical damage to the switch casing. Check wiring for signs of damage.

Every 6 months: Check each switch function by opening and closing each guard individually in turn and ensuring that the Green LED on the switch and the appropriate LED's on the safety relay are illuminated when the switch is closed and are extinguished when the switch is open. Check that the machine stops and cannot be re-started when each switch is open.

 **Warning!** The safety functions and the mechanics shall be tested regularly, at least once every year to confirm that all the safety functions are working properly.

 **Warning!** In case of breakdown or damage to the product, contact the nearest ABB Jokab Safety Service Office or reseller. Do not try to repair the product yourself since it may accidentally cause permanent damage to the product, impairing the safety of the device which in turn could lead to serious injury to personnel.

Caution! ABB Jokab Safety will not accept responsibility for failure of the switch functions if the installation and maintenance requirements shown in this sheet are not implemented. These requirements form part of the product warranty.

Minimum safety distance

When using interlocking guards without guard locking to safeguard a hazard zone, the minimum allowed safety distance between the guarded opening and the hazardous machine must be calculated. In order to ensure that the hazardous machine motion will be stopped before it can be reached, the minimum safety distance is calculated according to EN ISO 13855 ("Positioning of safeguards with respect to the approach speeds of parts of the human body").

The minimum safety distance is calculated according to the formula:

$$S = (K \times T) + C$$

Where

S = minimum safety distance (mm)

K = approach speed of a human body; 1600 mm/s

T = the total time from opening of the guard until the hazardous machine movement has stopped, i.e. including control system reaction times and other delays (s)

C = a safety distance taken from Table 4 or Table 5 of EN ISO 13857:2008, if it is possible to push fingers or a hand through the opening towards the hazard before a stop signal is generated

In some cases, T might be reduced by the opening time of the guard until the opening size permits access of the relevant parts of the body. Refer to EN ISO 13855 for further details and EN ISO 13857 for specified values.

5 Application examples

Application example

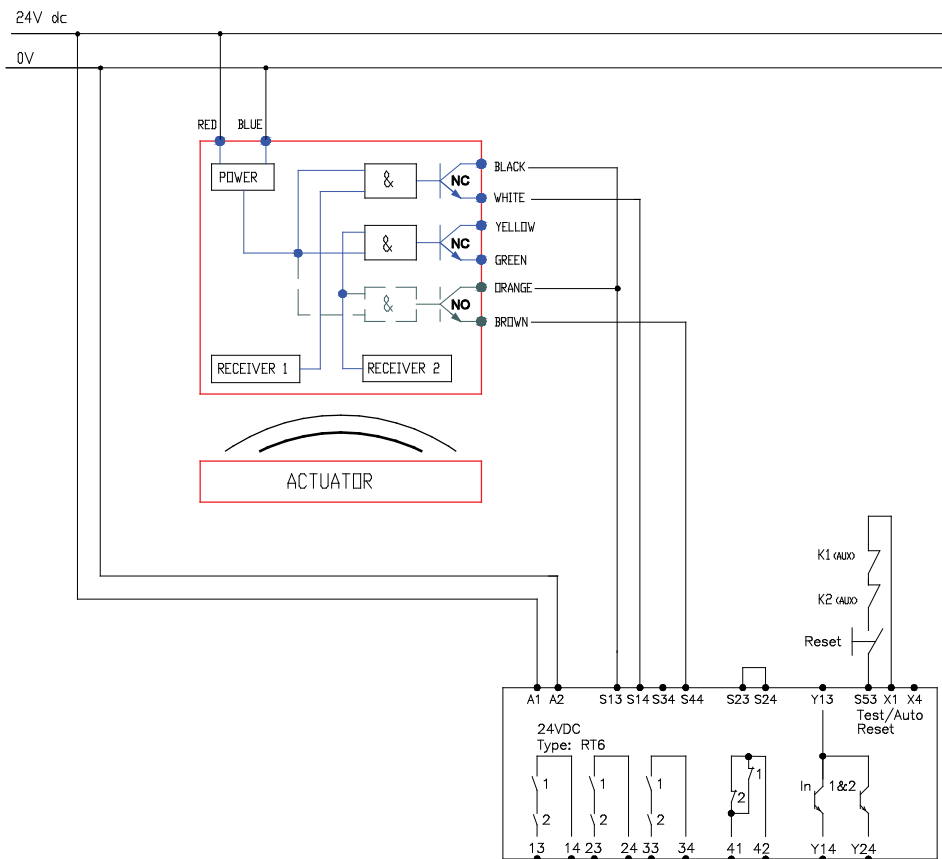
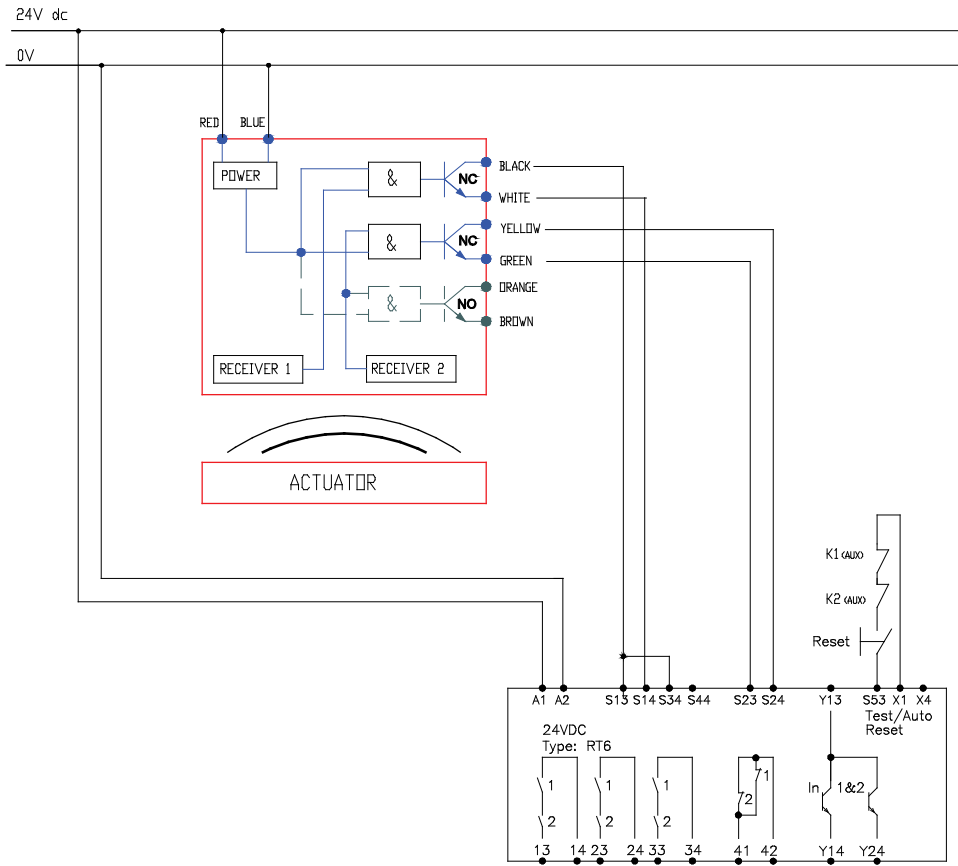

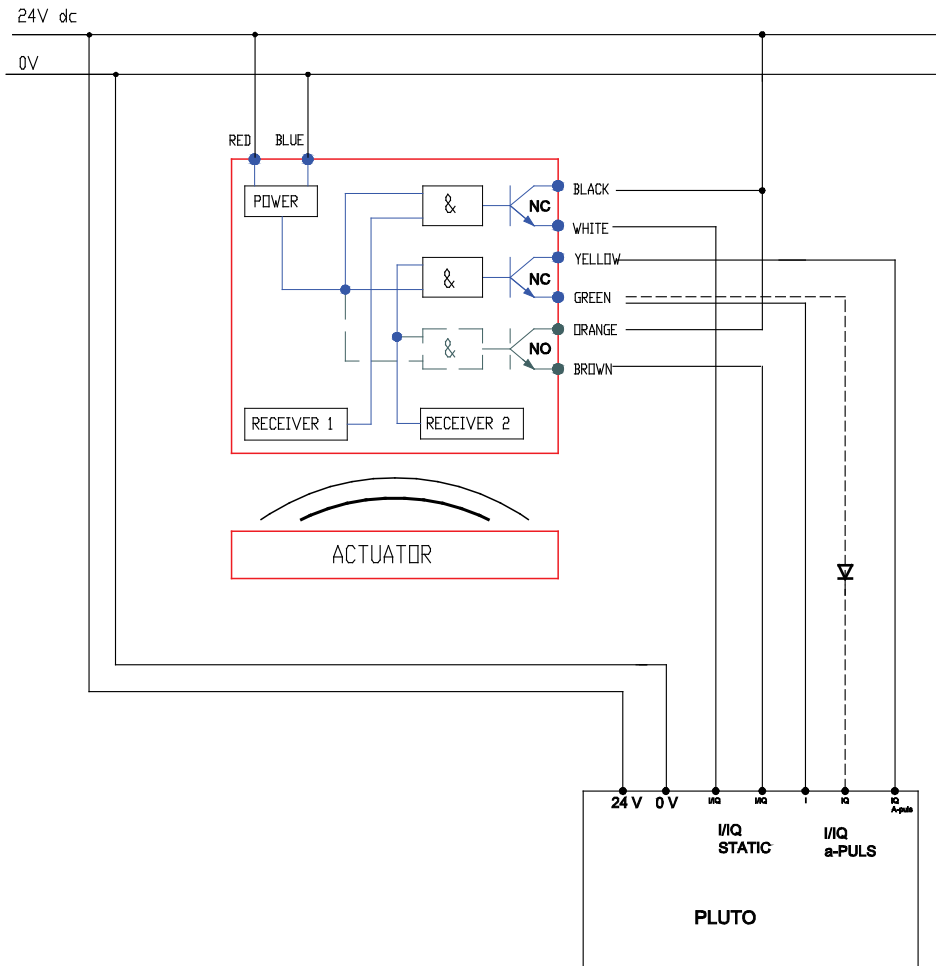

6 Model overview

Type	Article number	Description
Sense7	2TLA050056R4100	2 m cable, 2NC/1NO, LED
Sense7	2TLA050056R5100	5 m cable, 2NC/1NO, LED
Sense7	2TLA050056R6100	10 m cable, 2NC/1NO, LED
Sense7	2TLA050056R2100	250 mm cable with M12, 2NC/1NO, LED
Sense7Z	2TLA050056R4120	2 m cable, 2NC/1NO, LED, Stainless Steel
Sense7Z	2TLA050056R5120	5 m cable, 2NC/1NO, LED, Stainless Steel
Sense7Z	2TLA050056R6120	10 m cable, 2NC/1NO, LED, Stainless Steel
Sense7Z	2TLA050056R2120	250 mm cable with M12, 2NC/1NO, LED, Stainless Steel

Accessories

Type	Article number	Description
Sense7, actuator	2TLA050040R0211	Spare actuator plastic
Sense7, SS actuator	2TLA050040R0212	Spare actuator stainless steel

Dimensions

Sense7

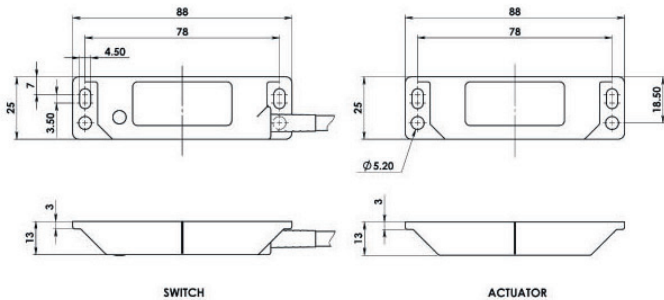

Sense7Z

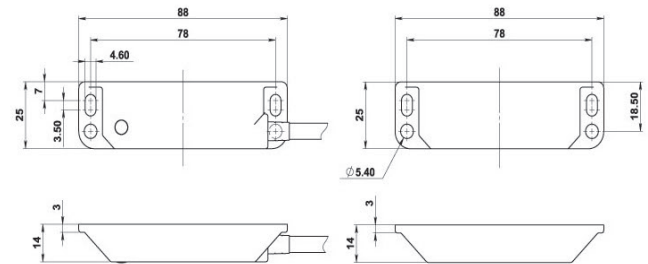

NB: All measurements in millimetres.

7 Technical data

Manufacturer	
Address	ABB AB / JOKAB SAFETY Varlabergsvägen 11 SE-434 39 Kungsbacka Sweden
Electrical characteristics	
Minimum switched current	10VDC 1mA
Dielectric withstand	250 VAC
Safety channel 1-NC	24VDC 0.2 A max. rating
Safety channel 2-NC	24VDC 0.2 A max. rating
Safety channel 3-NO	24VDC 0.2 A max. rating
Insulation resistance	100 MOhms
General	
Switching reliability	3.3×10^6 operations at 100mA load
Recommended setting gap	5 mm
Switching Distance (target to target)	S _{ao} 10 mm close (on) S _{ar} 20 mm open (off)
Tolerance to misalignment	5 mm in any direction from 5 mm setting gap
Switching frequency	1.0 Hz maximum
Approach speed	200 mm/m to 1000 mm/s
Vibration resistance	IEC 68-2-6, 10-55 Hz 1 mm
Shock resistance	IEC 68-2-27, 11 ms, 30 g
Protection class	IP69K
Cable Type	PVC 8 core 6 mm O.D
Ambient temperature	Sense7: -25°C to +80°C Sense7Z: -25°C to +105°C
Size	See drawing
Material	Sense7: UL approved polyester Sense7Z: Stainless steel 316
Colour	Red or stainless steel
Mounting position	Any
Mounting bolts	2 x M4 Tightening torque 1.0 Nm

Note that the red model (Sense7) is obsolete.
It is only the stainless steel model (Sense7Z) that is active.



Safety-related characteristic data and Conformity

Conformity	European Machinery Directive 2006/42/EC EN ISO 12100:2010, EN 1088:1995+A2:2008, EN ISO 13849-1:2008 EN 60947-5-2:2007, EN 60947-5-3:1999+A1:2005
EN ISO 13849-1	Up to PL e, cat. 4 depending on system architecture
EN 62061	Up to SIL3 depending on system architecture
Safety data	
PFH _D	2.52 x 10 ⁻⁸
B _{10d}	3,300,000 operations at 100 mA load
Proof test interval (life)	47 years
MTTF _d	470 years (8 cycles per hour/24 hours per day/365 days)
Certifications	TÜV, cULus
Information with regard to UL 508	Type 1 Enclosure Control No: 48W5 Max.Temp: 70°C (Plastic version), 90°C (Stainless Steel)

8 EC Declaration of conformity



EC Declaration of conformity

(according to 2006/42/EC, Annex 2A)

<p>We ABB AB JOKAB Safety Varlabergsvägen 11 SE-434 39 Kungsbacka Sweden</p>	<p>declare that the safety components of ABB AB manufacture with type designations and safety functions as listed below, is in conformity with the Directives 2006/42/EC 2006/95/EC 2004/108/EC</p>
<p>Authorised to compile the technical file</p>	<p>ABB AB JOKAB Safety Varlabergsvägen 11 SE-434 39 Kungsbacka Sweden</p>
<p>Product Non contact safety switches <u>Magnetic types</u> Sense2 Sense4 Sense4Z Sense6 Sense6Z Sense8 Sense6Z Sense10 Sense10Z Sense12, Sense12Z</p>	<p>Certificate 968/EZ 553.00/12 Pending</p>
<p><u>Coded types</u> Sense1 Sense3 Sense3Z Sense5Z Sense7 Sense7Z Sense9 Sense9Z Sense11 Sense 11Z Sense5</p>	<p>968/EZ 554.00/12 Pending</p>
<p>Certification Body</p>	<p>TÜV Rheinland Industrie Service GmbH Am Grauen Stein 51105 Köln Germany</p>
<p>Used harmonized standards</p>	<p>EN ISO 12100:2010, EN 1088:1995+A2:2008, EN ISO 13849-1:2008</p>
<p>Other used standards</p>	<p>EN 60947-5-2:2007, EN 60947-5-3:1999+A1:2005</p>
<p> Jesper Kristensson PRU Manager Kungsbacka 2012-08-06</p>	

www.abb.com
www.jokabsafety.com

Original

ABB AB / JOKAB SAFETY Varlabergsvägen 11, SE-434 39 Kungsbacka, Sweden

www.abb.com/jokabsafety