

# Installation & Operating Instructions

## 161LR (without test point) & 162LR (with test point)

### Loadbreak Elbow Connectors

**CONTENTS:** *Elbow Connector Housing, Compression Lug, Probe, Probe Wrench, Lubricant (Do Not Substitute), Installation/Operating Instructions.*

The 161LR (without test point) and 162LR (with test point) are designed to terminate various UD cables. The elbow provides an operating interface for connecting to an ElastimoldR 15kV class (8.3kV phase-to-ground and 14.4kV phase-to-phase) 200 ampere loadbreak bushing or accessory device with fault close rating of 10,000 amperes RMS symmetrical. When other types of UD cable are to be terminated, an appropriate ElastimoldR cable shield or grounding devices must be used.

#### DANGER

All apparatus must be de-energized during installation or removal of part(s) except for test point caps and indicators that can be installed and operated energized.

Do not touch or move energized products in the work area.

These instructions do not attempt to provide for every possible contingency.

Failure to follow these instructions will result in damage to the product and serious or fatal injury.

This product should be installed only by competent personnel trained in good safety practices involving high voltage electrical equipment. These instructions are not intended as a substitute for adequate training or experience in such safety practices.

All apparatus must be installed and operated in accordance with individual user, local and national work rules and electrical standards.

FOR MORE INFORMATION ON PARTS, INSTALLATION RATINGS AND COMPATIBILITY, CALL THE NEAREST ABB OFFICE.

If this product is supplied with a protective shipping cover(s), remove this shipping cover(s) and replace with the appropriate HV insulated cap(s) or connector(s) before submerging or energizing the circuit.

Inspect parts for damage, rating and compatibility with mating parts.

Excess distortion of the assembled product may result in its failure.

After installation loadbreak products can be operated energized per operating instructions. All deadbreak connectors must be de-energized before operating.

Connectors must be operated with a full insulated "hotstick" type tool. Consult the company's safe work practices for the required tool length.

#### Limited Warranty:

1. ABB Installation Products Inc. warrants that its products will be free from defects in materials or workmanship for a period of two (2) years, except for tools which are warranted separately (see warranty accompanying those products). Fisher Pierce<sup>®</sup> products and Elastimold<sup>®</sup> Reclosers are warranted for three years; and Joslyn<sup>®</sup> VBT and VBU capacitor switches are warranted for four years or 40,000 operations whichever occurs first. Upon prompt notification of a warranted defect, ABB Installation Products Inc. will, at its option, repair or replace the defective product.
2. In no event shall ABB Installation Products Inc. be liable for any consequential, indirect or special damages, nor will ABB Installation Products Inc. be liable for transportation, labor, or other charges arising out of the removal or reinstallation of its products. Liability for breach of warranty is limited to the cost of repair or replacement of the warranted product only.
3. Misuse, misapplication or modification of ABB Installation Products Inc. products immediately voids all warranties.

THE WARRANTIES AND REMEDIES CONTAINED HEREIN ARE EXCLUSIVE AND ARE IN LIEU OF ALL OTHER WARRANTIES AND REMEDIES, INCLUDING BUT NOT LIMITED TO ANY IMPLIED WARRANTIES OF MERCHANTABILITY AND FITNESS FOR A PARTICULAR PURPOSE, WHICH ARE SPECIFICALLY DISCLAIMED.

#### IMPORTANT

1. Check contents of package to ensure they are complete and undamaged.
2. Check all components to ensure proper fit with cable and/or mating products.
3. Check threads by threading probe into compression lug. If resistance is encountered prior to full assembly, check for damage and replace damaged component.
4. Read entire installation instructions before starting.
5. Have all required tools at hand and maintain cleanliness throughout the procedure.

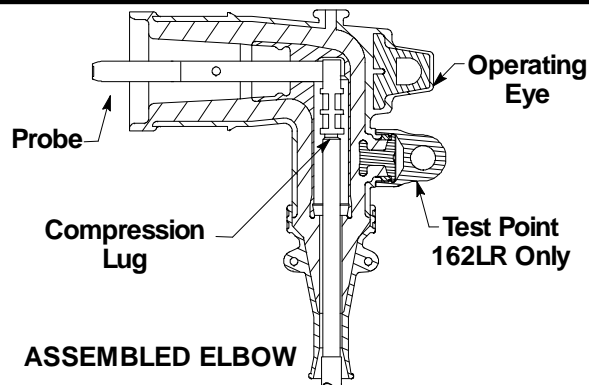

## STEP 1 CABLE TRAINING AND PREPARATION

### A. NON JACKETED CONCENTRIC NEUTRAL CABLE

1. Train cable to ensure slack for ease of operation.
2. To facilitate connection of the neutral to the tank ground and hotstick operation, an extra length of concentric neutral wires or grounding braid wire is required pursuant to one of the following methods:
  1. pull extra cable 24" to 36" (610-914 mm) beyond the centerline of the bushing and bind the neutrals 7-3/4" to 8" (195 to 203mm) further back from the bushing center;
  2. connect the neutral wires to the tank ground using a jumper or braid.
3. Unwrap the neutral wire to the binding.
4. Cut excess cable squarely at the centerline of the bushing.
5. Go to Step 2 to complete the installation.

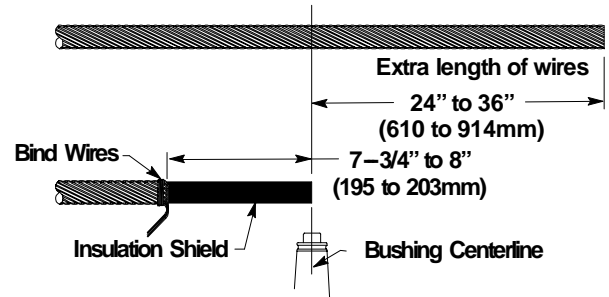

### B. JACKETED CONCENTRIC NEUTRAL CABLE

1. Train cable to ensure slack for ease of operation.
2. To facilitate connection of the neutral to the tank ground and hotstick operation, an extra length of concentric neutral wires or grounding braid wire is required pursuant to one of the following methods:
  1. pull extra cable 24" to 36" (610-914 mm) beyond the centerline of the bushing and place a tape mark at the centerline of the bushing. Then remove outer jacket 9-5/8" (240mm) further back from the tape mark;
  2. connect the neutral wires to the tank ground using a jumper or braid.
3. Unwrap the neutral wire back past the bushing centerline.
4. Cut excess cable squarely at the centerline of the bushing.
5. If using a 200ECS sealing kit, slide the cold shrink tube onto the cable loose end first.
6. Go to Step 2 to complete the installation.

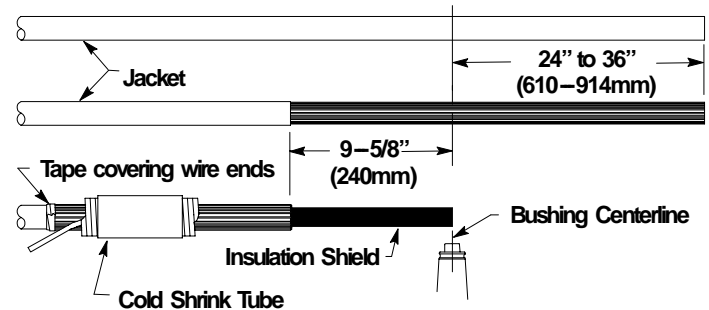

### C. JACKETED CABLE WITH DRAIN WIRES

1. Cut the cable squarely at the centerline of the bushing.
2. Remove 9-5/8" (240mm) of the outer jacket.
3. Unwrap the ground wires, DO NOT CUT OFF, bind and fold them back out of the way. Wrap a piece of vinyl tape around the cable covering the wire ends.
4. If using a 200ECS-G1 sealing kit, slide the cold shrink tube onto the cable loose end first.
5. Go to Step 2 to complete the installation.

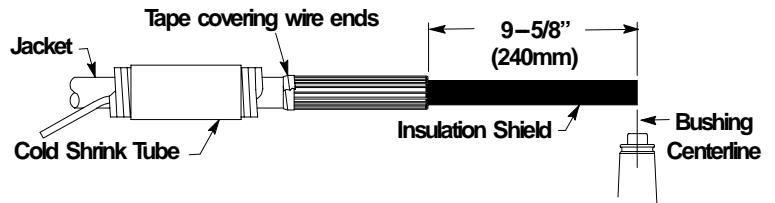

### D. JACKETED COPPER TAPE SHIELD CABLE

1. Cut the cable squarely at the centerline of the bushing.
2. Remove 9-5/8" (240mm) of the outer jacket.
3. Remove 7-1/8" (180mm) of the copper tape shield.

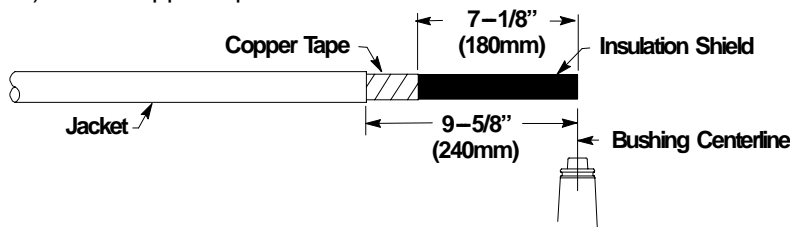

4. Wrap conductive copper tape, included with the 200ECS-G2 or G3 kit, over the end of the copper shield to hold it in place.
5. If using a 200ECS-G2 or G3 kit, slide the cold shrink tube onto the cable, loose end first.

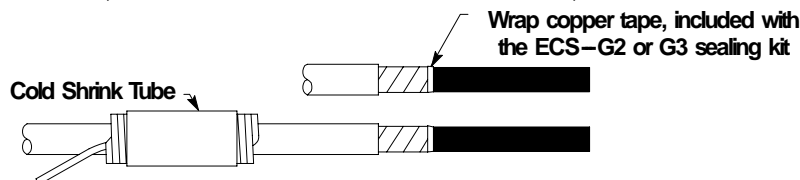

6. Go to Step 2 to complete the installation.

## STEP 2 CABLE PREPARATION

(Cable Cut Back Diagram located in the left margin is NOT to scale and is provided for reference only.)

- A. Remove the shield and insulation 2-1/8" (55mm) from the cable end. Cut squarely taking care not to nick conductor.



- B. Wire brush bare aluminum conductors and immediately install compression lug. Rotate to spread inhibitor. Position compression lug so the CONTACT THREADED HOLE ALIGNS WITH THE BUSHING BORE. (Refer to crimp chart packaged with compression lug for recommended crimp tool information.) Start crimp at the crimp line mark. Rotate 180\_ each successive crimp. Carefully wipe excess inhibitor from the outside of the lug and cable.

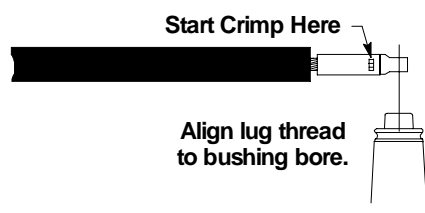

- C. Remove insulation shield as shown. Bevel insulation end 1/8" (5mm) max.

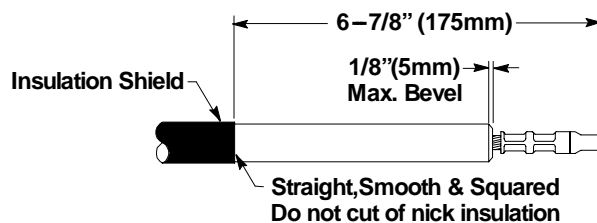

- D. Thoroughly clean insulation to remove all traces of dirt or excess inhibitor.

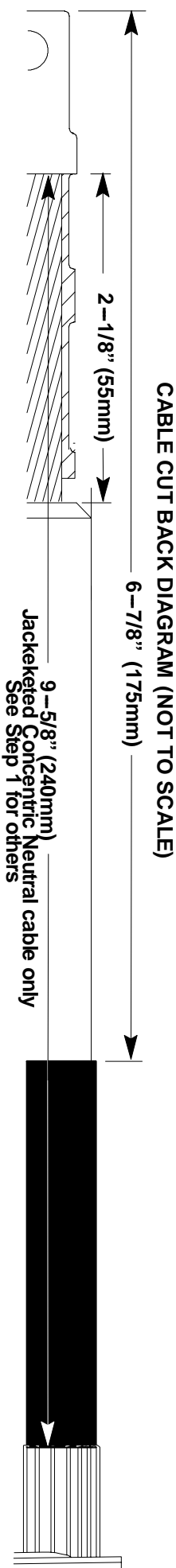

### STEP 3 ELBOW ASSEMBLY

- A. Lubricate the cable insulation and inside the elbow housing with the lubricant supplied. **DO NOT SUBSTITUTE.** Other lubricants may be harmful to this product or its mating product(s). Keep insulation clean of dirt and grime.
- B. Slide the elbow connector onto the cable with a back and forth twisting motion. Wipe off all excess lubricant.
- C. Align elbow with compression lug's threaded hole.
- D. Thread probe into lug by hand, taking care not to cross-thread. The probe **must** turn freely for approximately four turns before becoming snug. Tighten with wrench until wrench bends.

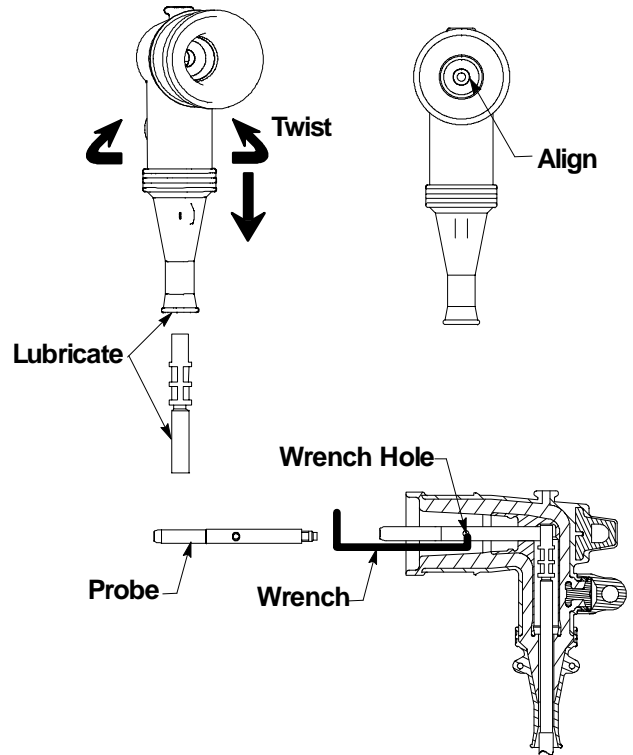

### STEP 4 GROUNDING

Insert one end of a separate copper wire (No. 14 AWG / 2.5mm) or equivalent through the grounding eye on the elbow. Twist tightly taking care not to damage the eye. If the elbow is preordered with ground wire, continue to concentric neutral connection section.

#### CONCENTRIC NEUTRAL CONNECTION

Twist all neutral wires and connect to ground using appropriate connector. Provide adequate slack in wires for elbow operation.

#### IF USING A COLD SHRINK GROUNDING KIT

Refer to the instructions supplied with the grounding kit to complete the installation.

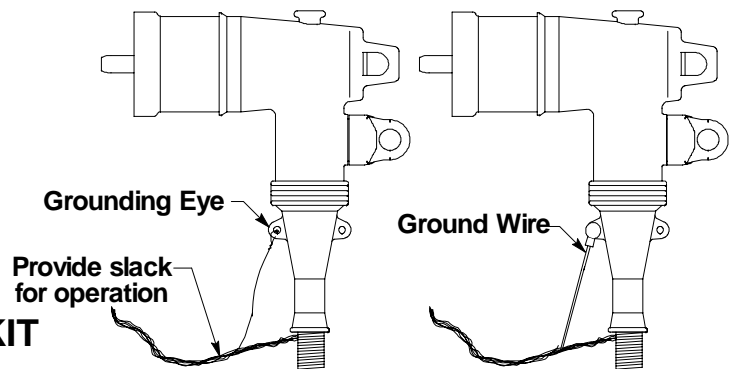

### STEP 5 CONNECT ELBOW AND BUSHING PLUG

- A. **CONFIRM THAT TRANSFORMER AND ELBOW ARE DE-ENERGIZED.**
- B. Lubricate the receptacle portion of the elbow connector and the mating bushing with the lubricant supplied.
- C. Operate per following instructions. **DO NOT OPERATE BY HAND.**

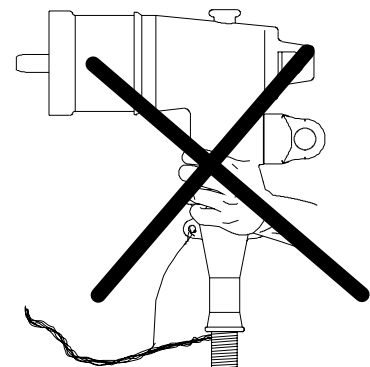
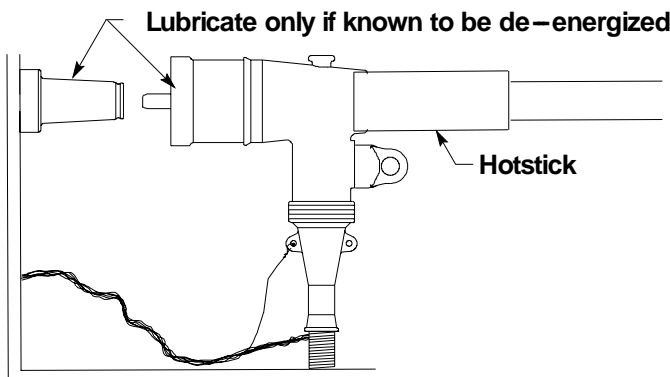

# OPERATING INSTRUCTIONS

## Before Loadmake or Loadbreak Operation:

Ensure connector is clean and free of any contaminants. Ensure work area is clear of obstructions to allow installer to establish firm footing and ensure a secure grasp on the hotstick tool. Maintain positive control over the movement of the loadbreak connector before, during and directly after the operating sequence. Because of the control, speed and force required to engage or disengage the elbow, certain operating positions are more advantageous than others. If there is some question as to proper operating position, it is recommended that the connectors be operated de-energized. Do not connect two different phases of a multiple-phase system. Before closing a single-phase loop, make certain both ends of the loop are the same phase.

## LOADMAKE OPERATION

**Loadbreak connectors must be operated with a full insulated "hotstick" type live-line tool. Consult the Utility's safe work practices for the required live-line tool length.**

1. To prepare bushing for elbow connector, remove insulated cap by attaching hotstick tool to the insulated cap pulling eye, and following the instructions for this accessory, remove from bushing.
2. Securely fasten the hotstick to the loadbreak connector pulling eye.
3. Confirm positive control of the elbow connector. Withdraw the elbow from the accessory device on the apparatus parking stand with a fast, straight, firm motion being careful not to place the elbow connector near a ground plane. Check appropriate accessory device operating instructions to be sure that the device is rated for energized operation.
4. Insert the probe tip approximately 2" (50mm) into the bushing (at this point the contacts are approximately 4" apart). **DO NOT HOLD IN THIS POSITION BUT IMMEDIATELY PUSH THE ELBOW HOME WITH A FAST, FIRM, STRAIGHT MOTION.**  
Use sufficient force to engage the internal lock on the elbow connector and bushing interface.

## Fault Close

1. **DO NOT CONDUCT LOADMAKE OPERATIONS ON KNOWN FAULTS.**
2. If a fault is experienced, both the elbow connector and the bushing must be replaced.

## LOADBREAK OPERATION

1. Place desired accessory device on apparatus parking stand. Refer to appropriate operating instructions for accessory device to be used. Confirm device is rated for energized operation.
2. Firmly tighten the hotstick to the loadbreak connector pulling eye.
3. Without exerting any pulling force, slightly rotate (clockwise) the connector in order to break surface friction prior to disconnection.
4. Withdraw the connector from the bushing with a fast, firm, straight motion, being careful not to place the connector near a ground plane.
5. Place connector on appropriate accessory device, following the operating instructions for that accessory.

## VOLTAGE TEST

ELASTIMOLDR connectors equipped with an integral capacitance test point can be used to determine whether or not the circuit is energized.

When using the test point, complete the following steps:

1. Remove test point cap with the hotstick. When removing cap, PEEL OFF AT AN ANGLE rather than pulling directly in line with the test point assembly.
  2. **WARNING:** THE VOLTAGE TEST POINT IS A CAPACITANCE DEVICE, IT IS NOT DIRECTLY CONNECTED TO THE CONDUCTOR. Do not use conventional voltage measuring equipment. Follow the manufacturer's directions for the meter that is used. Test with a suitable sensing device, made for use with separable connectors manufactured with capacitive test points, to determine if cable is energized. Contamination, moisture, dirt, etc. around the test point or use of the wrong measuring equipment can provide a false "no voltage" indication on an energized elbow. To prevent serious or fatal injury treat the elbow as energized until the "no voltage" test point indication is confirmed by other means.
  3. After voltage detection has been made, clean the inside surface of the cap and lubricate with silicone lubricant supplied; and replace it on the test point.
-