



Industrial Lighting

Hubbell Industrial Lighting | EL Series



CONTENTS

ABOUT ELECTRONIC HID

Electronic HID information..... 2
 Electronic Ballasts..... 5

HIGHBAY

EL Series BI 6
 EL Series EG 7
 EL Series SU/SD/AL 8

LOWBAY

EL Series LM 9
 EL Series LB1 10

GLASS

EL Series HGX-16/HGX-22 11

ACRYLIC

EL Series PA2 12
 EL Series WA22/WW22 13
 EL Series WA25 14
 EL Series SW 15

ELECTRONIC HID

Electronic HID is a new kind of HID ballast – with microprocessor-based technology that delivers a genuine, quantum leap in metal halide performance. Performance measured by extraordinary, unprecedented lumen maintenance capabilities means huge opportunities for operating cost reductions, both through energy savings and lower maintenance requirements. In addition, Electronic HID also helps turn color shift, lamp blackening and lack of control into long-gone problems of the past.

In applications where fluorescent options such as T5/HO are beginning to provide an HID alternative, users looking for a positive cost/benefit equation now have more choices – and more ways to enjoy the rewards of better lighting.

REVOLUTIONARY TECHNOLOGY DELIVERS REVOLUTIONARY VALUE

With the introduction of Electronic HID electronic ballasts for HID systems, Hubbell Industrial has established totally new benchmarks for performance and cost savings.

The key to understanding the true value of this innovation is something called "lumen maintenance," or the lamp/ballast system's ability to minimize light output depreciation over the life of the lamp. Conventional HID systems – magnetic ballasts driving probe start metal halide lamps – typically experience a 50-60% fall-off in light output over the published life of the lamp. This fall-off can lead to excessive maintenance costs due to the need for frequent re-lamping, and inefficient energy usage throughout the life of the system.



Electronic HID changes the rules by delivering a 30-50% improvement in lumen maintenance over these conventional systems. By maintaining higher light levels across the entire published life of the lamp, the system delivers significant value to the end user in three key ways:

- **30-50% IMPROVED LUMEN MAINTENANCE LEADS UP TO 50% LESS LAMP REPLACEMENT COSTS**
- **56% MORE LUMENS ENABLES THE USE OF UP TO 36% FEWER FIXTURES**
- **36% FEWER FIXTURES LEADS TO 41% ENERGY SAVINGS – ANNUALLY!**

10-YEAR OVERALL COST OF OWNERSHIP REDUCED UP TO 36%

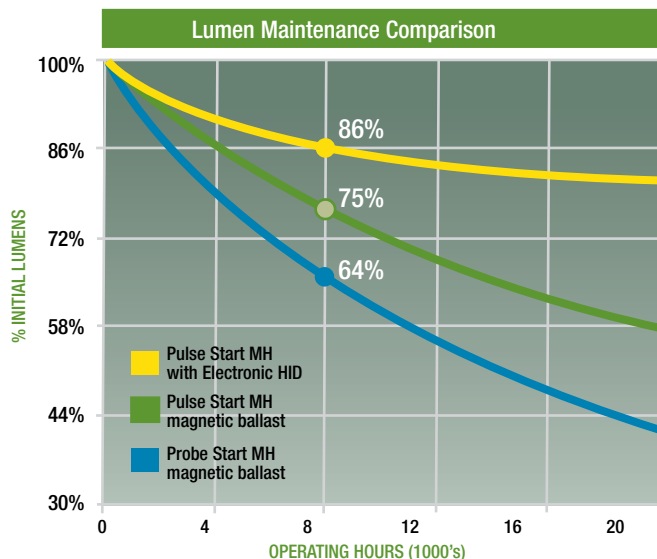

ELECTRONIC HID

IMPROVED LUMEN MAINTENANCE = LESS LAMP MAINTENANCE

Most lighting systems are designed on the basis of mean or “average” light output of the lamp. For metal halide (MH) lamps, this mean light output, as measured in lumens, defined at 40% of the lamp’s rated life. Since most medium wattage MH lamps are rated at 20,000 hours of lamp life, mean lumens are advertised at 8,000 hours of lamp life.

As lumens fall off after the 8,000 hr. design point, the lighting level for many applications may become unacceptable, resulting in the need for re-lamping significantly prior to reaching the 20,000 hr. rated life of the lamp.

Because of Electronic HID’s relatively flat lumen depreciation characteristic, (i.e., better lumen maintenance), early re-lamping is unnecessary, resulting in a more cost-effective lighting system. In the example below, consider identical installations with 400 fixtures: one with magnetic ballasts where lamps are replaced at 12,000 hours, and a second where lamp life is extended to 18,000 hours.

In this example, Electronic HID would save on average \$10 per fixture, per year, just in reduced maintenance costs! The assumption was made that an equal number of fixtures were used. Next, consider the total consequences of producing more light, longer, with fewer fixtures... and discover its true advantage.

	Conventional Magnetic Pulse Start	Electronic HID
Number of Fixtures	400	400
Annual burn hours	5,000	5,000
Lamps replaced at (hrs.)	12,000	18,000
Lamp cost per each re-lamping	\$10,000 (@ \$25/lamp)	\$10,000 (@ \$25/lamp)
Fixture cleaning & lamp replacement labor	\$10,000 (@ \$25/fixture)	\$10,000 (@ \$25/fixture)
Number of replacements in 10 years	4	2
Total 10-year cost of lamp changes	\$80,000	\$ 40,000
10-YEAR LAMP MAINTENANCE SAVINGS = \$40,000!		

EQUIVALENT LIGHT LEVELS:

400W Probe Start – 150 Fixtures 400W Electronic HID– 96-100 Fixtures

Benefits of Fewer Fixtures

- *Faster Installation*
- *Lower Material Costs*
- *Lower Labor Costs*
- *Lower Maintenance Costs*
- *Lower Energy Costs*
- *Lower Total Cost of Ownership*

A 400W Electronic HID system produces up to 56% more mean lumens over conventional probe start systems using the same wattage lamps. Taking advantage of this performance benefit, the overall fixture count can be reduced by up to 36% without sacrificing light levels. Plus, fewer fixtures also have a dramatic impact on both energy and maintenance costs, leading to significantly lower overall operating costs.

ELECTRONIC HID

Electronic HID Features	Benefits and Advantages
Microprocessor technology	Lower operating and maintenance costs
High frequency operation	Fewer fixtures
True constant wattage	Energy savings
320/350/400 Tri-Wattage	Fewer SKU's Less chance for error
Multivolt 200-277V 50/60 Hz	Ease of change over to different wattage lamps
Integral 120V quartz tap and relay, 250W	Standby-lighting ready No special orders No special relay or control required
0-10V dimming with automatic 15-minute warm up	Continuous dimming down to 50% lamp power Additional energy savings through daylight harvesting and occupancy sensing
Lamp end-of-life protection	Safety

MORE ABOUT...STANDBY LIGHTING VERSATILITY

Electronic HID's 120-volt output is designed to operate one quartz (incandescent) standby lamp up to 250W. The quartz lamp on or off modes are determined by the HID lamp's specific operating conditions. Once the HID lamp strikes, the quartz lamp automatically switches off when the HID lamp reaches 50% power.

CONTROLLABILITY

Electronic HID is dimmable – down to 50% of nominal lamp power, with no noticeable loss in color characteristics. With 0-10V dimming, and compatible with a host of products from most control manufacturers, Electronic HID brings new flexibility and energy-saving strategies, such as daylight harvesting and occupancy sensing, to applications in the industrial, educational, government, hospitality, commercial and retail sectors.

APPLICATION SPECIFICATIONS

Pulse Start Metal Halide

Lamp Data		Min Start Temp. (F/C)	Input Volts	Listings	Line Cur. (A)	Input Power ANSI (W)	Ballast Factor	Max. THD %	Min. PF %
No.	Watts								

320-Watt Lamp, ANSI Code M132/M154

1	320	-20/-30	200 to 277	UL SF	1.8 1.3	345 345	1.0	15	90
---	-----	---------	------------	-------	------------	------------	-----	----	----

350-Watt Lamp, ANSI Code M131

1	350	-20/-30	200 to 277	UL SF	1.9 1.4	375 375	1.0	15	90
---	-----	---------	------------	-------	------------	------------	-----	----	----

400-Watt Lamp, ANSI Code M135/M155

1	400	-20/-30	200 to 277	UL SF	2.2 1.6	430 430	1.0	15	90
---	-----	---------	------------	-------	------------	------------	-----	----	----

NOTE: These specifications apply to operation of pulse start metal halide lamps with quartz one-tube construction only. For operating compatibility with ceramic one-tube lamps consult Hubbell Industrial.



DIMMING FEATURE

With 0-10V interface, the Electronic HID electronic ballasts offer the capability to dim the lamp by lowering the wattage lamp, reducing energy consumption of the light fixture by up to 50%. This interface can be used with either a commercially available 0-10V dimming control, a 0-10V DC power supply, or with a switch. An open switch provides full lamp power and a closed switch, short-circuiting the 0-10V wires, yields 50% lamp power. Control devices such as relays and occupancy sensors may also be used.

A potentiometer may also be used. However, the value of the potentiometer is dependent on the number of ballasts connected. Consult Hubbell Industrial for guidance. In accordance with the requirements of the HID lamp manufacturers and NEMA, the dimming feature includes a time delay to allow the HID lamp to warm up for 15 minutes at full power before the lamps will be allowed to dim, regardless of the level of the 0-10V signal.

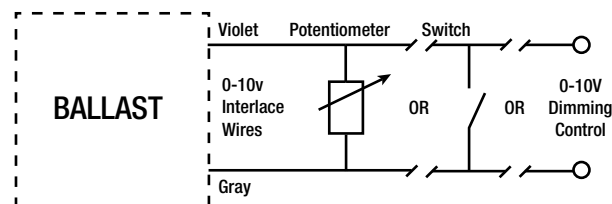

WIRE INFORMATION

Wire Color	Function
Black	Input Power
White	Input Power
Green	Ground
Red	Lamp Eyelet
Blue	Lamp Screwshell
Yellow (2)	120V Lamp Output
Violet	0-10V Dimming (+)
Grey	0-10V Dimming (-)

All lead lengths are 11.0" +/- 1.0" and are 0.5" pre-stripped.

ELECTRONIC BALLASTS

EL SERIES STEEL HOUSING

Introducing EL Series Electronic Ballast

The new Hubbell Industrial Lighting EL Series Electronic Ballast delivers a new level of HID performance:

- Lower operating and maintenance costs.
- Better lumen maintenance – light output depreciation cut 30%-50%.
- Fewer fixtures needed to light the same space over standard MH.
- Energy savings of more than 40% per year.
- Variable dimming to 50% of lamp power.

More Lumens

- Electronic HID raises the performance of pulse start lamps to a new level.
- Electronic HID systems deliver 35% more light at mean lumen output than traditional probe-start systems and nearly 50% more light by end of life.

More Energy Efficient

- Electronic HID systems are far more efficient, reducing operating costs up to 40% per year when compared to probe-start systems.

More Savings to the Bottom Line

- Regardless of the way you compare the products, Electronic HID represents the best solution for delivering great lighting at a great price.

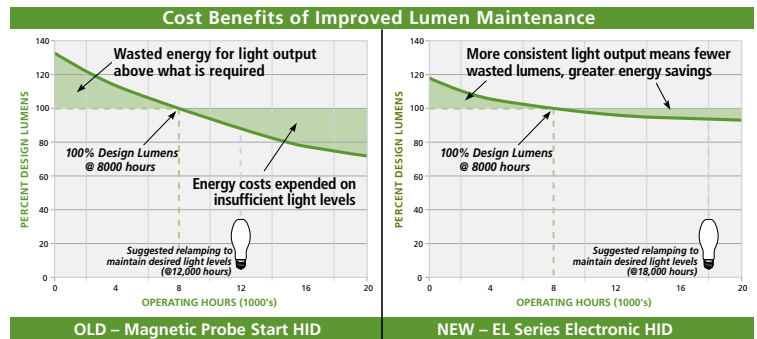
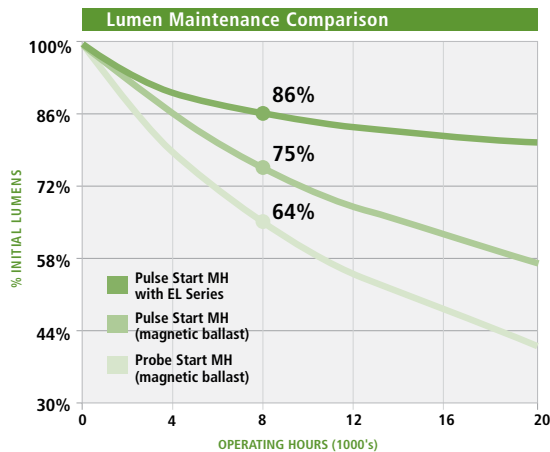

10-Year Overall Cost of Ownership = 36% Reduction

Consider an example of lighting a new 300 ft. x 300 ft. retail space with a 24 ft. ceiling to a minimum illumination level of 100 footcandles at a work-plane height 30 inches. Never has a new technology had the potential to contribute so significantly to the bottom line. Even with the EL's higher initial cost, the savings over a 10-year operating cycle can be as high as 36%, as the following model illustrates:

	400W Probe Start Magnetic CWA	400W Pulse Start Magnetic SCWA	400W Pulse Start Electronic HID
Mean Lumens per Lamp	23,400	31,000	37,000
Input Watts per Fixture	458	452	425
Number of Fixtures Required	462	352	295
Fixture Cost, each	\$150	\$175	\$275
Lamp Cost, each	\$15	\$25	\$25
Fixture Cost, total	\$69,300	\$61,600	\$81,125
Lamp Cost, total	\$6,930	\$8,800	\$7,375
Installation Labor	\$23,100	\$17,600	\$14,750
Installation Materials	\$138,600	\$105,600	\$88,500
Total Installed Cost	\$237,930	\$193,600	\$191,750
Savings	—	18.6%	19.4%
Annual Energy Costs (@ \$0.10/KWH)	\$105,798	\$79,552	\$62,688
Savings	—	25%	41%
10 Year Lamp Replacements and Cleanings	\$46,200	\$44,000	\$36,875
Savings	—	5%	20%
10 Year Cost of Ownership	\$1,342,110	\$1,033,120	\$855,500
Savings	—	23%	36%
Savings vs. 400W Probe Start	—	\$308,990	\$486,610

EL SERIES

BI



Mogul Base



Features

The EL Series BI is ideal for light manufacturing areas, warehouse and retail aisles. Steel ballast housings should be used in areas with minimal airborne contaminants.

The EL Series BI features an Anodal® finished 14" diameter spun aluminum reflector for improved optical performance. Field adjustable brackets provide narrow, medium and wide lighting distributions for application flexibility.

Steel housing with white polyester powder coat finish. All electrical components are positioned to assure unit will hang straight. Housing is ventilated for optimal thermal performance.

Electronic ballast is 100% factory tested. Ballast will operate pulse start lamps only, from 200-277V.

Glazed porcelain, vertical oriented, mogul-base socket with copper alloy, nickel-plated screw shell and center contact. UL listed 1500W, 600V, 4KV pulse rated. Protected version with pink exclusionary socket available. Will continuously dim from 100% to 50% of light. Use provided 0-10v dimming leads.

Listed to U.S. and Canadian safety standards.
45° C ambient temperature limit. Damp locations.

Ordering Information

Example: EL - 40 P 4 - BI - WH

Series

EL Electronic Highbay Series

Wattage

32 320 watt Pulse Start MH
35 350 watt Pulse Start MH
40 400 watt MH, Pulse Start MH

Source

P Pulse Start Metal Halide

Voltage

2 208V
3 240V
4 277V

Optics

NM No Optics, housing made for BI reflector
BI 14" spun aluminum highbay reflector with uplight

Bottom Enclosure

BL-LR-14 Bottom Enclosure

Color

WH White (standard)
GR Gray
BZ Bronze
GL Galvanize

Series Watts Source Volts Optics Color

For a complete list of options and accessories see pages 60 to 70.

Dimensions

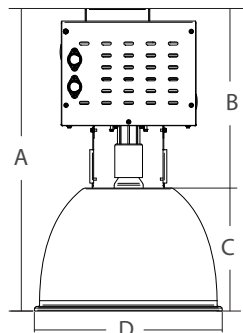

A	B	C	D
23 1/2"	13 15/16"	9 9/16"	14 11/16"
598 mm	355 mm	243 mm	372 mm

EL SERIES

EG

HIGHBAY

Features

The EL Series EG is ideal for light manufacturing areas, warehouse and retail aisles. Steel ballast housings should be used in areas with minimal airborne contaminants.

The EL-EG 19" diameter reflector system excludes dirt and dust, maintaining desired performance. It is white polyester powder coated and has a clear glass bottom lens. Note: shown with optional CFB (charcoal filter breather) on reflector.

Steel housing with white polyester powder coat finish. All electrical components are positioned to assure unit will hang straight. Housing is ventilated for optimal thermal performance.

Electronic ballast is 100% factory tested. Ballast will operate pulse start lamps only, from 200-277V.

Glazed porcelain, vertical oriented, mogul-base socket with copper alloy, nickel-plated screw shell and center contact. UL listed 1500W, 600V, 4KV pulse rated. Protected version with pink exclusionary socket available. Will continuously dim from 100% to 50% of light. Use provided 0-10v dimming leads.

Listed to U.S. and Canadian safety standards.
45° C ambient temperature limit. Damp locations.



Mogul Base



Ordering Information

Example: EL - 35 P 4 - EG - WH
 Series Watts Source Volts Optics Color

Series	EL Electronic Highbay Series	Optics		Color	
Wattage	32 320 watt Pulse Start MH	NM	No Optics, housing made for EG reflector	WH	White (standard)
	35 350 watt Pulse Start MH	EG	19" spun aluminum highbay enclosed & gasketed reflector	GR	Bronze
	40 400 watt MH, Pulse Start MH			GL	Galvanize
Source	P Pulse Start Metal Halide				
Voltage	2 208V				
	3 240V				
	4 277V				

For a complete list of options and accessories see pages 60 to 70.

Dimensions

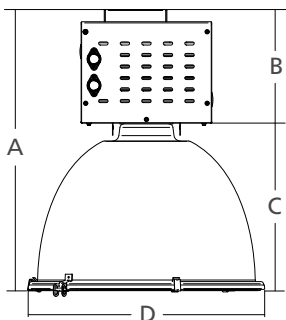

A	B	C	D
29 15/16"	11 1/2"	13 1/2"	19"
761 mm	292 mm	342 mm	483 mm

EL SERIES

SU/SD/AL



Mogul Base



Features

The EL Series SU/SD/AL is ideal for light manufacturing areas, warehouse and retail aisles. Steel ballast housings should be used in areas with minimal airborne contaminants.

The SU optic is ideally suited for new construction or retrofit lighting. The uplight component softens the overall brightness difference between the luminaire and surrounding area. The SD optic is an Anodal® finished 19" spun aluminum reflector engineered for applications requiring downlight only. The AL optic economically lights the vertical surfaces of warehouses and storage area stacks.

Steel housing with white polyester powder coat finish. All electrical components are positioned to assure unit will hang straight. Housing is ventilated for optimal thermal performance.

Electronic ballast is 100% factory tested. Ballast will operate pulse start lamps only, from 200-277V.

Glazed porcelain, vertical oriented, mogul-base socket with copper alloy, nickel-plated screw shell and center contact. UL listed 1500W, 600V, 4KV pulse rated. Protected version with pink exclusionary socket available. Will continuously dim from 100% to 50% of light. Use provided 0-10v dimming leads.

Listed to U.S. and Canadian safety standards.

45° C ambient temperature limit. Damp locations.

Ordering Information

Example: EL - 40 P 4 - SU - WH

Series

EL Electronic Highbay Series

Wattage

- 32 320 watt Pulse Start MH
- 35 350 watt Pulse Start MH
- 40 400 watt MH, Pulse Start MH

Source

P Pulse Start Metal Halide

Voltage

- 2 208V
- 3 240V
- 4 277V

Optics

- NM No Optics, housing made for SU/SD/AL reflector
- SU 19" spun aluminum highbay reflector with uplight
- SD 19" spun aluminum highbay reflector with downlight only
- AL 19" spun aluminum highbay aisle lighter reflector

Bottom Enclosure

BL-LR-19 Bottom Enclosure

Color

- WH White (standard)
- GR Gray
- BZ Bronze
- GL Galvanize

For a complete list of options and accessories see pages 60 to 70.

Dimensions

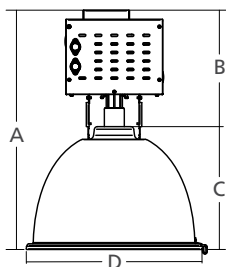

	A	B	C	D
SU	28 1/4"	16 11/32"	11 15/16"	19"
	718 mm	415 mm	303 mm	483 mm

	A	B	C	D
SD	25 15/16"	12 5/8"	13 5/16"	19"
	658 mm	320 mm	338 mm	483 mm

	A	B	C	D
AL	27 1/2"	14 7/32"	13 5/16"	19"
	699 mm	361 mm	338 mm	483 mm

EL SERIES

LM

Features

The EL Series LM is ideal for light manufacturing areas, warehouse and retail aisles. Steel ballast housings should be used in areas with minimal airborne contaminants.

The EL-LM Series is designed for many years of demanding, heavy-duty industrial service. Ideally suited for low to medium mounting heights in areas requiring good horizontal uniformity and high vertical illumination. LM's low brightness refractor produces wide distribution without harsh shadows while projecting light into machinery for optimum yet comfortable visibility.

29" spun aluminum with white Lektrocote® finish. Hinged and latched with corrosion-resistant steel hardware for ease in relamping. Computer-designed acrylic refractor (polycarbonate available) is UV stabilized for long life and durability. Prismatic refractor provides square distribution to enhance uniformity and increase fixture spacing.

Steel housing with white polyester powder coat finish. All electrical components are positioned to assure unit will hang straight. Housing is ventilated for optimal thermal performance.

Electronic ballast is 100% factory tested. Ballast will operate pulse start lamps only, from 200-277V.

Glazed porcelain, vertically oriented, mogul-base socket with copper alloy, nickel-plated screw shell and center contact. UL listed 1500W, 600V, 4KV pulse rated. Protected version with pink exclusionary socket available. Will continuously dim from 100% to 50% of light. Use provided 0-10v dimming leads.

Listed to U.S. and Canadian safety standards.
45° C ambient temperature limit. Damp locations.



Mogul Base



LOWBAY

Ordering Information Example: EL - 40 W 4 - LM - WH

	Series	Watts	Source	Volts	Optics	Color
Series	EL	Electronic Highbay Series				
Wattage	32	320 watt Pulse Start MH				
	35	350 watt Pulse Start MH				
	40	400 watt MH, Pulse Start MH				
Source	P	Pulse Start Metal Halide				
Voltage	2	208V				
	3	240V				
	4	277V				
Optics	NE	No Optics, housing made for LM optic				
	LM	29" Spun Aluminum Lowbay with bottom lens enclosure				
Color	WH	White (standard)				
	GR	Gray				
	BR	Bronze				
	GL	Galvanize				

For a complete list of options and accessories see pages 60 to 70.

Dimensions

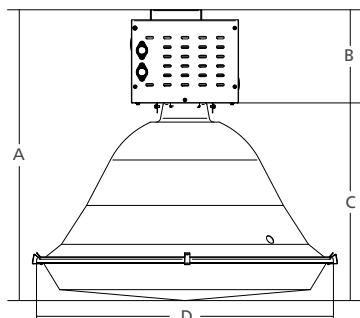

A	B	C	D
28 1/2"	9 1/8"	19 3/8"	29 1/8"
723 mm	232 mm	492 mm	739 mm

EL SERIES

LB1

Features

The EL Series LB1 is ideal for light manufacturing areas, warehouse and retail aisles. Steel ballast housings should be used in areas with minimal airborne contaminants.

Reflector is spun, high purity, heavy-gauge aluminum with white Lektrocote® paint finish inside and out. Hinged and latched with corrosion-resistant steel hardware. Computer-designed acrylic refractor (polycarbonate available) is UV stabilized for long life and durability. Refractor provides square distribution to enhance uniformity and increase fixture spacing.

Steel housing with white polyester powder coat finish. All electrical components are positioned to assure unit will hang straight. Housing is ventilated for optimal thermal performance.

Electronic ballast is 100% factory tested. Ballast will operate pulse start lamps only, from 200-277V.

Glazed porcelain, vertically oriented, mogul-base socket with copper alloy, nickel-plated screw shell and center contact. UL listed 1500W, 600V, 4KV pulse rated. Protected version with pink exclusionary socket available. Will continuously dim from 100% to 50% of light. Use provided 0-10v dimming leads.

Listed to U.S. and Canadian safety standards.
45° C ambient temperature limit. Damp locations.

LOWBAY



Mogul Base



Ordering Information Example: EL - 40 P 4 - LB1 - WH

Series	Watts	Source	Volts	Mounting	Optics	Color
EL	Electronic Highbay Series					
Wattage						
32	320 watt Pulse Start MH					
35	350 watt Pulse Start MH					
40	400 watt MH, Pulse Start MH					
Source						
P	Pulse Start Metal Halide					
Voltage						
2	208V					
3	240V					
4	277V					
Optics						
NN	No Optics, housing made for LB1 optics					WH White (standard)
LB1	23" Spun Aluminum Lowbay with bottom lens refractor					GR Gray
						BZ Bronze
						GL Galvanize

For a complete list of options and accessories see pages 60 to 70.

Dimensions

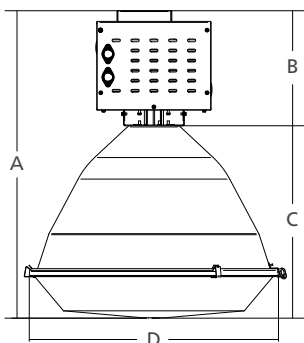

A	B	C	D
30 5/8"	12 15/16"	17 3/4"	22 15/16"
778 mm	328 mm	450 mm	581 mm

EL SERIES

HGX-16/HGX-22

Features

The EL Series HGX16/HGX-22 is ideal for light manufacturing areas, warehouse and retail aisles. Steel ballast housings should be used in areas with minimal airborne contaminants.

The HGE-16/HGE-22 and HGO-16/HGE-22 Series glass reflectors are manufactured from shock and impact resistant borosilicate glass, providing good uplight and three dimensional lighting. These high quality glass optics come with a specially designed ballast housing engineered for maximum performance.

The reflector is mounted to the ballast housing by a combination of die cast aluminum socket housing and rigid, zinc-coated wire form. The die cast aluminum socket housing is available as an open unit (HGO-16) or as an enclosed unit (HGE-16). The open unit allows airflow through the inside of the glass optic to help maintain a clean reflector. The open unit is damp location listed. The enclosed unit seals off the top of the glass optic to prevent dirt and dust from entering the reflector and is damp location listed. To seal the bottom, order lens shown below. Both glass optics offer the best resistance to the widest variety of corrosive industrial chemicals and are easily cleaned and maintained.

Steel housing with white polyester powder coat finish. All electrical components are positioned to assure unit will hang straight. Housing is ventilated for optimal thermal performance.

Electronic ballast is 100% factory tested. Ballast will operate pulse start lamps only, from 200-277V.

Glazed porcelain, vertically oriented, mogul-base socket with copper alloy, nickel-plated screw shell and center contact. UL listed 1500W, 600V, 4KV pulse rated. Protected version with pink exclusionary socket available. Will continuously dim from 100% to 50% of light. Use provided 0-10V dimming leads

Listed to U.S. and Canadian safety standards.
45° C ambient temperature limit. Damp locations.



Mogul Base



GLASS

Ordering Information

Example: EL - 40 P 4 - HGE-16 - WH

Series	Watts	Source	Volts	Optics	Color
EL	Electronic Highbay Series				
32	320 watt Pulse Start MH				
35	350 watt Pulse Start MH				
40	400 watt MH, Pulse Start MH				
P	Pulse Start Metal Halide				
2	208V				
3	240V				
4	277V				
NH	No Optics, housing made for HGX-16				
NI	No Optics, housing made for HGX-22				
HGE-16	16" Glass Reflector/Enclosed (lower luminaire retainer included standard)				
HGO-16	16" Glass Reflector/Open (lower luminaire retainer included standard)				
HGE-22	22" Glass Reflector/Enclosed (lower luminaire retainer included standard)				
HGO-22	22" Glass Reflector/Open (lower luminaire retainer included standard)				
				Bottom Enclosure Glass	
				HGENC16 Bottom Enclosure	
				HGENC22 Bottom Enclosure	
				Color	
				WH White (standard)	
				GR Gray	
				BZ Bronze	
				GL Galvanize	

For a complete list of options and accessories see pages 60 to 70.

Dimensions

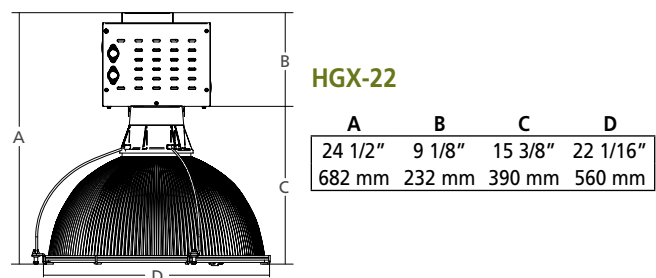
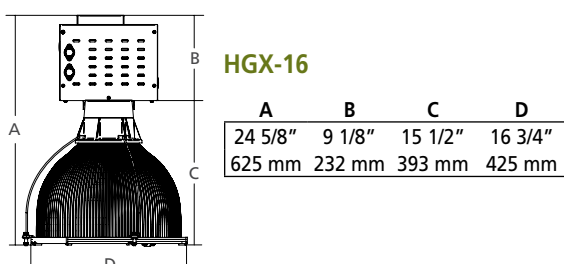

EL SERIES

PA2



Mogul Base



Features

The EL Series PA2 is ideal for light manufacturing areas, warehouse and retail aisles. Steel ballast housings should be used in areas with minimal airborne contaminants.

Designed for lower wattage and lower mounting heights. EL-PA2 Series 16" diameter acrylic reflector combines attractive appearance with superb performance.

Field-adjustable brackets allow for medium to wide lighting distributions. For best performance and visual comfort, coated lamps are recommended.

Electronic ballast is 100% factory tested. Ballast will operate pulse start lamps only, from 200-277V.

Glazed porcelain, vertically oriented, mogul-base socket with copper alloy, nickel-plated screw shell and center contact. UL listed 1500W, 600V, 4KV pulse rated. Protected version with pink exclusionary socket available. Will continuously dim from 100% to 50% of light. Use provided 0-10v dimming leads.

Listed to U.S. and Canadian safety standards.
45° C ambient temperature limit. Damp locations.

Ordering Information

Example: EL - 40 P 4 - PA2 - WH

Series Watts Source Volts Optics Color

Series

EL Electronic Highbay Series

Wattage

32 320 watt Pulse Start MH

35 350 watt Pulse Start MH

40 400 watt MH, Pulse Start MH

Source

P Pulse Start Metal Halide

Voltage

2 208V

3 240V

4 277V

Optics

NP No Optics, housing made for

PA2 optics

PA2 16" Prismatic Acrylic Reflector

Bottom Enclosure

BL-PK-ENC Bottom Enclosure

PA2-CDL Conical Bottom Enclosure

PA2-DLR Drop Lens Bottom Enclosure

Color

WH White (standard)

GR Gray

BZ Bronze

GL Galvanize

ACRYLIC

For a complete list of options and accessories see pages 60 to 70.

Dimensions

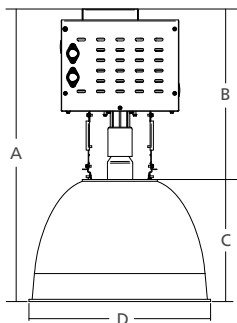

A	B	C	D
23 1/8"	15 1/4"	10 15/16"	16 1/4"
664 mm	387 mm	277 mm	412 mm

EL SERIES

WA22/WW22

Features

The EL Series WA22/WW22 is ideal for light manufacturing areas, warehouse and retail aisles. Steel ballast housings should be used in areas with minimal airborne contaminants.

The WA22 Series is designed for low to medium mounting heights in task areas demanding excellent vertical and horizontal illumination. The lightweight prismatic acrylic reflector generates wide, uniform light distribution with minimum glare and reduces harsh shadows on vertical work surfaces. Acrylic composition of the reflector versus glass enhances work place safety.

Injection molded UV-stabilized acrylic. Field adjustable socket brackets allow for medium to wide distribution patterns. Use coated (diffuse) lamps for optimum photometric performance. Unit shown with optional WA22-CDL conical bottom enclosure.

Steel housing with white polyester powder coat finish. All electrical components are positioned to assure unit will hang straight. Housing is ventilated for optimal thermal performance.

Electronic ballast is 100% factory tested. Ballast will operate pulse start lamps only, from 200-277V.

Glazed porcelain, vertically oriented, mogul-base socket with copper alloy, nickel-plated screw shell and center contact. UL listed 1500W, 600V, 4KV pulse rated. Protected version with pink exclusionary socket available. Will continuously dim from 100% to 50% of light. Use provided 0-10v diming leads.

Listed to U.S. and Canadian safety standards.
45° C ambient temperature limit. Damp locations.



Mogul Base



Ordering Information

Example: EL - 40 P 4 - WA22 - WH
Series Watts Source Volts Mounting Optics

Series	EL Electronic Highbay Series
Wattage	32 320 watt Pulse Start MH
	35 350 watt Pulse Start MH
	40 400 watt MH, Pulse Start MH
Source	P Pulse Start Metal Halide
Voltage	2 208V
	3 240V
	4 277V

Optics	ND No Optics, housing made for WA22/WW22 optics
	WA22 22" Wide Acrylic Reflector
	WW22 22" Opaque Prismatic Acrylic
Bottom Enclosure	WA2-ENC Bottom Enclosure
	WA22-CDL Conical Bottom Enclosure
	WA22-DLR Drop Lens Bottom Enclosure

Color	WH White (standard)
	GR Gray
	BR Bronze
	GL Galvanize

ACRYLIC

For a complete list of options and accessories see pages 60 to 70.

Dimensions

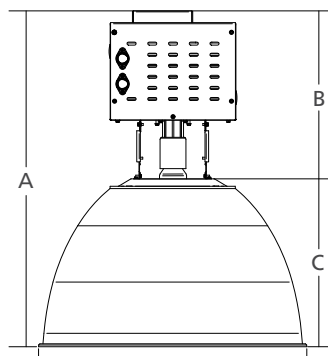

A	B	C	D
30 3/8"	16 3/8"	14 1/16"	22 7/16"
772 mm	416 mm	356 mm	569 mm

EL SERIES

WA25



Mogul Base



Features

The EL Series WA25 is ideal for light manufacturing areas, warehouse and retail aisles. Steel ballast housings should be used in areas with minimal airborne contaminants.

The WA25 Series is designed for 20 to 30 foot mounting heights in areas that call for efficient three-dimensional illumination as well as good looks.

Field adjustable socket brackets allow for medium to wide distribution patterns. For optimum performance and visual comfort, coated lamps are recommended.

Steel housing with white polyester powder coat finish. All electrical components are positioned to assure unit will hang straight. Housing is ventilated for optimal thermal performance.

Electronic ballast is 100% factory tested. Ballast will operate pulse start lamps only, from 200-277V.

Glazed porcelain, vertically oriented, mogul-base socket with copper alloy, nickel-plated screw shell and center contact. UL listed 1500W, 600V, 4KV pulse rated. Protected version with pink exclusionary socket available. Will continuously dim from 100% to 50% of light. Use provided 0-10v dimming leads.

Listed to U.S. and Canadian safety standards.
45° C ambient temperature limit. Damp locations.

Ordering Information

Example: EL - 40 P 4 - WA25 - WH

Series Watts Source Volts Optics Color

Series

EL Electronic Highbay Series

Wattage

32 320 watt Pulse Start MH

35 350 watt Pulse Start MH

40 400 watt MH, Pulse Start MH

Source

P Pulse Start Metal Halide

Voltage

2 208V

3 240V

4 277V

Optics

NL No Optics, housing made for WA25 optics

WA25 25" Wide Acrylic Reflector

Bottom Enclosure

WA25-ENC Bottom Enclosure

WA25-DLR Drop Lens Bottom Enclosure

Color

WH White (standard)

GR Gray

BR Bronze

GL Galvanize

ACRYLIC

For a complete list of options and accessories see pages 60 to 70.

Dimensions

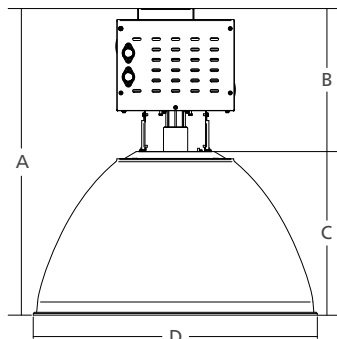

A	B	C	D
25 3/8"	12 3/4"	14 5/8"	25 3/8"
644 mm	324 mm	371 mm	644 mm

EL SERIES

SW

Features

The EL Series SW is ideal for light manufacturing areas, warehouse and retail aisles. Steel ballast housings should be used in areas with minimal airborne contaminants.

Superwatt 2.0 is designed to deliver comfortable, high efficiency illumination for both vertical as well as horizontal surfaces. With its 2.2:1 spacing-to-mounting height ratio, it is well suited for low and medium mounting height applications requiring three-dimensional, high illumination.

27% uplight softens the brightness difference between luminaire and surrounding areas. The maximum downward candlepower is projected at 45° from vertical for wide distribution and the greatly reduced candlepower above 65° minimizes direct glare.

Steel housing with white polyester powder coat finish. All electrical components are positioned to assure unit will hang straight. Housing is ventilated for optimal thermal performance.

Electronic ballast is 100% factory tested. Ballast will operate pulse start lamps only, from 200-277V.

Glazed porcelain, vertically oriented, mogul-base socket with copper alloy, nickel-plated screw shell and center contact. UL listed 1500W, 600V, 4KV pulse rated. Protected version with pink exclusionary socket available. Will continuously dim from 100% to 50% of light. Use provided 0-10v dimming leads

Listed to U.S. and Canadian safety standards.
40° C ambient temperature limit. Damp locations.



Mogul Base



Ordering Information Example: EL - 40 P 4 SW - WH

Series Watts Source Volts Optics Color

Series	EL Electronic Highbay Series	Optics	NC No Optics, housing made for SW optics
Wattage	32 320 watt Pulse Start MH	SW	Superwatt® Optics
	35 350 watt Pulse Start MH	Color	WH White (standard)
	40 400 watt MH, Pulse Start MH	GR	Gray
Source	P Pulse Start Metal Halide	BZ	Bronze
Voltage	2 208V	GR	Galvanize
	3 240V		
	4 277V		

ACRYLIC

For a complete list of options and accessories see pages 60 to 70.

Dimensions

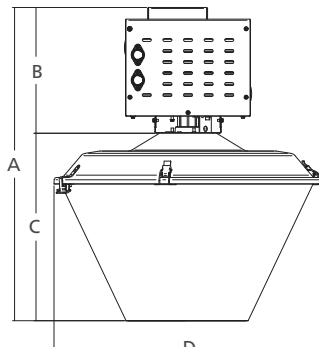

A	B	C	D
26.31"	10.57"	15.75"	22.520"
668 mm	268 mm	400 mm	572 mm



Hubbell Lighting
Outdoor & Industrial

Hubbell Lighting Outdoor & Industrial Solutions

PRECISION FLOODLIGHTING

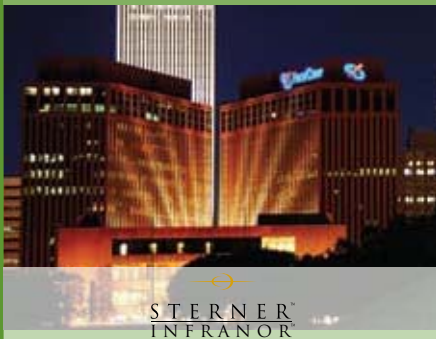

FLOODLIGHTING



WALL/SURFACE LIGHTING



SPORTS LIGHTING



LOW LEVEL PEDESTRIAN



AREA LIGHTING



For more information visit our web site: www.hubbellindustrial.com

Hubbell Lighting Inc. Distinguished Lighting Brands

Alera Lighting
Architectural Area Lighting
Columbia Lighting
Devine Lighting
Dual-Lite
Hubbell Outdoor Lighting
Hubbell Industrial Lighting
Kim Lighting



Prescolite
Progress Lighting
Security Lighting Systems
Spaulding Lighting
Sterner Lighting Systems
Sportsliter Solutions
Whiteway
Kurt Versen

United States
Hubbell Lighting, Inc.
701 Millennium Boulevard
Greenville, SC 29607
864-678-1000

Canada
Hubbell Canada
870 Brock Road
Pickering, Ontario L1W 1Z8
www.hubbell-canada.com

Mexico
Hubbell De Mexico, S.A. DE CV
Av. Coyoacan No. 1051
Col. Del Valle • 03100 Mexico, D.F.
www.hubbell.com.mx

Due to our continued efforts to improve our products, product specifications are subject to change without notice.

**Replacement labor, equipment charges and all resulting liability issues are the responsibility of the owner. This warranty is valid only if all lamp manufacturer's operating and installation instructions are followed and the specific Hubbell Lighting light fixture installation instructions and application recommendations are followed. Lamp failures due to physical damage, electrical surges, or other acts of nature are not covered by this warranty.