

NELES

Valv-Powr™ VPVL mod D Value-Line™ double-opposed piston actuators

Installation, maintenance and
operating instructions



TABLE OF CONTENTS

1. GENERAL.....	3
1.1 Warning	3
1.2 Handling VPVL Actuators	3
2. TECHNICAL DATA	3
3. INSTALLATION	4
3.1 General.....	4
3.2 Operation	4
4. MAINTENANCE	4
4.1 General.....	4
4.2 Disassembly.....	4
4.3 Assembly	7
5. SAFETY LOCKOUT DEVICE	10
6. Declutchable Manual Override (DO)	12
6.1 Installation	12
6.2 Stop screw adjustment.....	12
6.3 Operation	12
7. ACTUATOR STORAGE	13
8. SERVICE / SPARE PARTS.....	13
9. EXPLODED VIEW.....	13

READ THESE INSTRUCTIONS FIRST!

These instructions provide information about safe handling and operation of the valve.

If you require additional assistance, please contact the manufacturer or manufacturer's representative.

Subject to change without notice.

All trademarks are property of their respective owners.

SAVE THESE INSTRUCTIONS!

Addresses and phone numbers are printed on the back cover.

1. GENERAL

This instruction manual contains important information regarding the installation, operation, and troubleshooting of the Jamesbury® *Valv-Powr* VPVL Mod D *Value-Line* Double-Opposed Piston Actuators. Please read these instructions carefully and save them for further reference.

As the use of the VPVL X is application specific, many factors should be considered when selecting an actuator for a given application. Therefore, some of the situations in which the actuators are used are outside the scope of this manual. If you have any questions concerning the use, application or compatibility of the actuator with the intended service, contact Neles for more information.

Please read these instructions carefully and save them for further reference.

1.1 WARNING:

LOSS OF AIR PRESSURE MAY CAUSE SPRING-RETURN ACTUATORS TO MOVE TO THEIR 'FAILURE' POSITION. APPLYING AIR PRESSURE OR CONTROL SIGNAL TO VALVE/ACTUATOR ASSEMBLY MAY CAUSE THE ASSEMBLY TO OPERATE.

BEWARE OF MOVEMENT OF THE VALVE AND ANY LINKAGE BETWEEN IT AND THE ACTUATOR. KEEP HAND, BODY PARTS, TOOLS AND OTHER OBJECTS OUT OF THE WAY OF MOVING PARTS. FAILURE TO DO THIS MAY RESULT IN DAMAGE OR PERSONAL INJURY!

ALWAYS KEEP HANDS AND CLOTHING AWAY FROM THE VALVE PORTS. A CLOSING VALVE ACTS AS A CUTTING DEVICE.

DO NOT TRY TO MANUALLY OPERATE A PRESSURIZED ACTUATOR.

DISASSEMBLING A PRESSURIZED ACTUATOR WILL LEAD TO UNCONTROLLED RELEASE OF PRESSURE. SHUT OFF SUPPLY PRESSURE AND RELEASE THE PRESSURE FROM THE ACTUATOR BEFORE DISASSEMBLY. FAILURE TO FOLLOW THESE INSTRUCTIONS MAY RESULT IN DAMAGE OR PERSONAL INJURY!

DISASSEMBLY OF A SPRING-RETURN ACTUATOR MAY BE DANGEROUS.

NEVER ATTEMPT TO DISASSEMBLE THE SPRING CARTRIDGE ASSEMBLY OF A SPRING-RETURN ACTUATOR. DISASSEMBLY OF THE SPRING CARTRIDGE ASSEMBLY MAY RESULT IN SERIOUS PERSONAL INJURY! IF MAINTENANCE IS REQUIRED THE ENTIRE SPRING-RETURN ACTUATOR SHOULD BE DIRECTED TO A NELES SERVICE CENTER.

SHUT OFF AND BLEED ALL SUPPLY LINES BEFORE INSTALLATION OR SERVICING THE ACTUATOR. BEFORE INSTALLING THE VALVE AND ACTUATOR, BE SURE THAT THE INDICATOR POINTER ON TOP OF THE ACTUATOR (AND THE IDENTIFICATION PLATE IN FEMALE ACTUATORS) ARE CORRECTLY INDICATING THE VALVE POSITION. FAILURE TO ASSEMBLE THESE PRODUCTS TO INDICATE CORRECT VALVE POSITION COULD RESULT IN DAMAGE OR PERSONAL INJURY!

THE ACTUATOR MUST BE SIZED ACCURATELY FOR PROPER OPERATION. REFER TO INFORMATION ON THE ACTUATOR END OF STROKE TORQUES AND THE APPROPRIATE VALVE BULLETIN FOR OPERATING TORQUES.

WHEN SERVICING A VALVE ACTUATOR ASSEMBLY, THE BEST PRACTICE IS TO REMOVE THE ENTIRE ASSEMBLY FROM SERVICE. IF THE ACTUATOR IS REMOVED FROM THE VALVE, IT SHOULD BE REMOUNTED ON THAT SAME VALVE AFTER SERVICING IS COMPLETED. THE ACTUATOR MUST BE READJUSTED FOR PROPER "OPEN" AND "CLOSE" POSITION EACH TIME IT IS REMOUNTED.

DO NOT USE VDI/VDE MOUNTING HOLES TO LIFT AN ACTUATOR.

OPERATING AN ACTUATOR ABOVE ITS TEMPERATURE LIMITS MAY DAMAGE INTERNAL AND EXTERNAL COMPONENTS AND MAY RESULT IN PERSONAL INJURY!

OPERATING OVER THE PUBLISHED PRESSURE LIMITS OF THE ACTUATOR MAY RESULT IN DAMAGE OR FAILURE OF THE ACTUATOR HOUSING, AND MAY RESULT IN PERSONAL INJURY!

1.2 Handling VPVL Actuators

When handling the actuator or valve/actuator assembly, take its weight into account! Approximate actuator weights are shown in the technical bulletin. Never lift the actuator or valve/actuator assembly by the actuator positioner, limit switch, their piping, or an NPT air connection. Handling of the actuator should be accomplished using lifting straps. Failure to follow these instructions may result in damage or personal injury from falling parts. Obey any local or national requirements.

2. TECHNICAL DATA

- 1. Operating Media:** Air, Nitrogen
Air Quality: Acc. to ISO 8573-1
Solid particles: Maximum particle size 30 µm
Humidity: Dew point equal to -20 °C or 10 °C / 18 °F below ambient temperature
- 2. Air Supply:** 116 psi (8 bar) Maximum.
- 3. Temperature Range:**
Standard -40°F to +176°F (-40 °C to +80 °C)
High Temp 5°F to +302°F (-15 °C to +150 °C)
Low Temp -60°F to +176°F (-51 °C to +80 °C)
- 4. Lubrication:** Factory lubricated for the life of the actuator under normal operating conditions.
- 5. Construction:** Suitable for indoor and outdoor use.
- 6. External Travel Stops:** -5° up +5° on the Closed position and +5° down to -5° in the Open position.

Double-Acting (Top View)

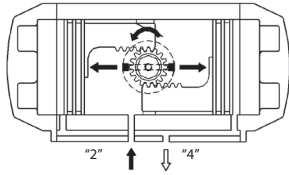

Air supplied to **Port 2** forces pistons apart and toward end positions with exhaust air exiting at **Port 4** (a counterclockwise rotation is obtained).

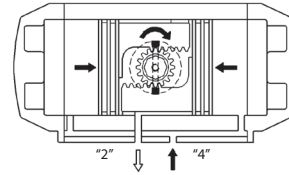

Air supplied to **Port 4** forces pistons toward center with exhaust air exiting at **Port 2** (a clockwise rotation is obtained).

Figure 1

Spring-Return (Top View) Spring-to-Close

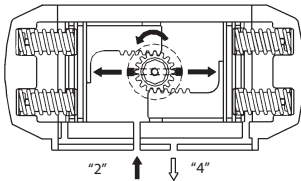

Air supplied to **Port 2** forces pistons apart and toward end position, compressing springs. Exhaust air exits at **Port 4** (a counterclockwise rotation is obtained).

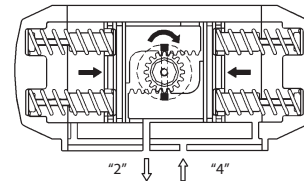

Loss of air pressure allows springs to force pistons toward center position with exhaust air exiting at **Port 2** (a clockwise rotation is obtained).

Figure 2

3. INSTALLATION

3.1 General

1. Check to see that the desired failure mode is correct (**Figures 1 & 2**). In the spring-to-close mode, the actuator will cycle clockwise to close upon loss of pressure. If the spring-return actuator is not set up in the configuration desired, follow the disassembly procedure section 4.2. Reverse the orientation of the pistons, then reassemble following the assembly procedure, section 4.3.
2. Mount the actuator to the valve, following the direction in the linkage AMI or valve IMO.
3. Connect a regulated air supply to the NPT fitting in the actuator housing. **CAUTION: The maximum operating pressure is 116 psi (8 bar).**
4. Adjust the stop screws following **ASSEMBLY** Section 4.3.5.

3.2 Operation

1. The actuator series, size, operating pressure, operating temperature, output torque, spring directions, and drive type is determined by the actuator designation.
2. The label lists the actuator series, size, operating pressure, maximum pressure, and serial number.
3. Actuator designation example, VPVL300SR6BD is a spring-return series, VPVL300 double-opposed piston actuator that has 80-psi (5.5-bar) springs, a Teflon[®]-coated anodized housing (protection B), an end-of-stroke output torque of 44.9 FT•LBS (60.8 N•m).

4. MAINTENANCE

4.1 General

Although Neles *Jamesbury* actuators are designed to work under severe conditions, proper preventative maintenance can significantly help to prevent unplanned downtime and in real terms reduce the total cost of ownership. Neles recommends inspecting actuators at least every five (5) years. The inspection and maintenance frequency depends on the actual application and process condition.

NOTE: All VPVL actuator fasteners are metric. Under normal operating conditions the actuator requires only periodic observation to ensure proper adjustment. Repair kits are available to replace seals and bearings (soft parts). These parts are identified in (**Figure 23**) and listed in (**Table 3**). (**Table 1**) below lists kit part numbers.

4.2 Disassembly

When disassembly of the actuator is required for maintenance, remove the actuator from the valve. Ensure proper lifting procedures are followed when moving or carrying actuators. **CAUTION: Do not use the M5 VDI / VDE mounting holes or the M6 hole in the pinion for lifting the actuator.**

TABLE 1		
Complete Repair Kit		
Actuator	Standard	High Temp.
VPVL-051	RKP-262	RKP-233
VPVL-100	RKP-263	RKP-234
VPVL-200	RKP-264	RKP-235
VPVL-250	RKP-265	RKP-236
VPVL-300	RKP-266	RKP-237
VPVL-350	RKP-267	RKP-238
VPVL-400	RKP-268	RKP-239
VPVL-450	RKP-269	RKP-240
VPVL-500	RKP-270	RKP-241
VPVL-550	RKP-271	RKP-242
VPVL-600	RKP-272	RKP-243
VPVL-650	RKP-273	RKP-244
VPVL-700	RKP-274	RKP-245
VPVL-800	RKP-275	RKP-246

CAUTION: Disconnect any pneumatic or electrical supplies, and vent any air pressure in the actuator before attempting any disassembly.

1. Removal of Position Indicator (19,20), (Figure 3):

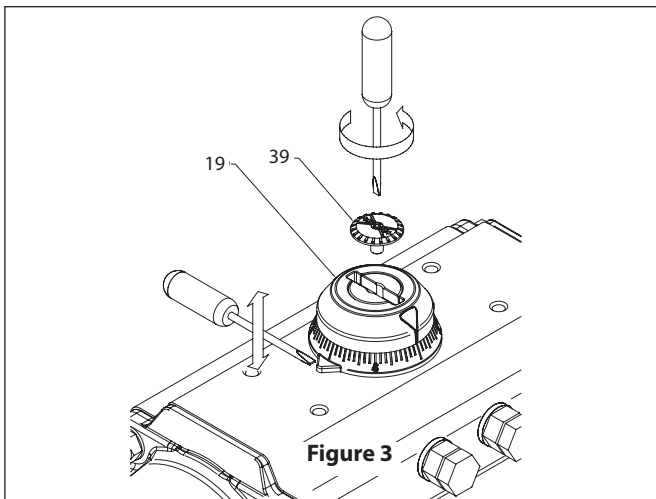

A. Remove cap screw if fitted (39).

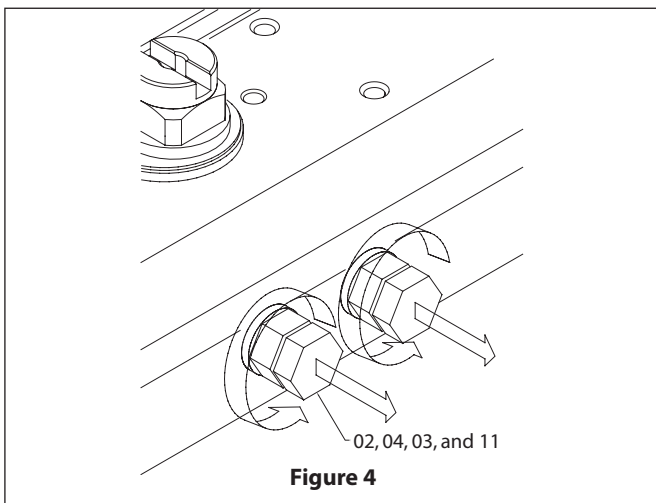

B. Lift position indicator (19) off shaft; it may be necessary to pry gently with a screwdriver.

2. Removal of Stop Cap Screws (02), (Figure 4):

A. Remove both stop cap screws (02) together with nut (04) and washer (03).

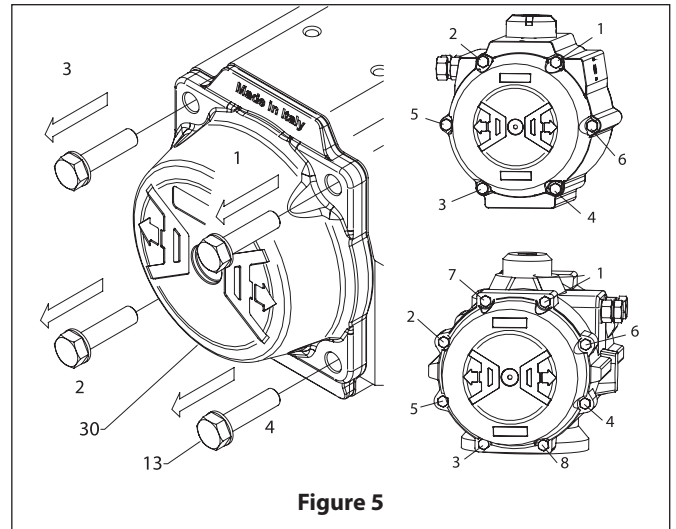

B. Remove stop screw o-rings (11) and discard if replacing all soft parts.

3. End Cap (30) Disassembly, (Figure 5):

A. Remove the end cap bolts (13) in the sequence shown in (Figure 5).

CAUTION (VPVL051): The springs within the spring return version of the size "051" actuator are not captured in a cartridge. The end cap bolts are 30mm long to allow the spring force to be completely released prior to removal of the end caps (30). Slowly back out all 4 end cap screws (13) evenly to allow the spring force to be safely released prior to removal of the end cap (30).

CAUTION (VPVL100 - 800): When disassembling a spring return actuator, the end cap (30) should be loose after unscrewing the end cap bolts (13) 4-5 turns. If there is still force on the end cap (30) after 4-5 turns of the end cap bolts (13), this may indicate a damaged spring cartridge and any further disassembly of the end cap may result in serious personal injury! Re-tighten the end cap bolts and direct the complete actuator to a Neles Service Center for further maintenance.

B. For spring return actuators, remove spring cartridges (17).

CAUTION: Disassembly of the spring cartridge should not be attempted. Special equipment is required. Disassembly of the spring cartridge may result in serious personal injury. If maintenance is required, the entire spring-return actuator should be directed to a Neles Service Center.

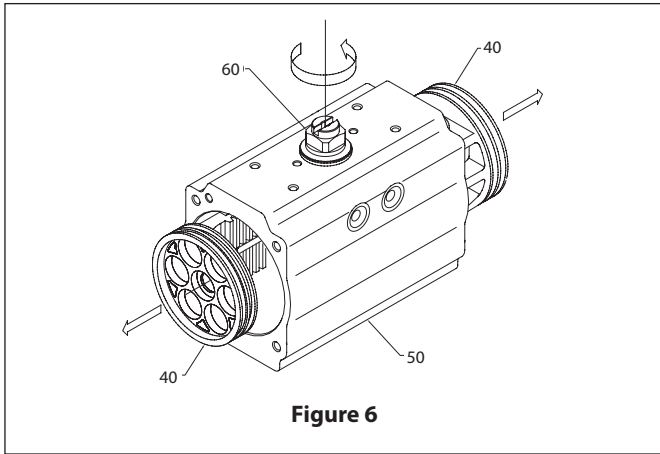

Figure 6

C. Remove end-cap o-rings (14) and discard if replacing all soft parts.

4. Piston (40) Disassembly, (Figure 6):

A. Holding the body (50) in a vice (or similar device), rotate the drive shaft (60) until the pistons (40) are released. **CAUTION: Do not use air pressure to remove pistons from actuator housing.** Clean and inspect the piston teeth for signs of wear. Replace piston if wear seems excessive.

B. Remove piston o-ring seal (16) using a screwdriver. Remove the piston head (15) and piston back (5) bearings. Discard bearings if replacing all soft parts.

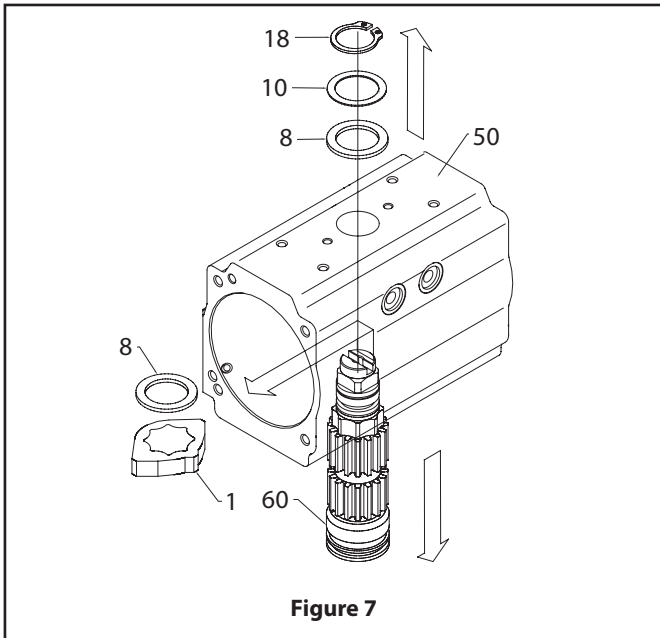

Figure 7

5. Drive Shaft (60) and Bearing (6, 7) Disassembly, (Figure 7):

A. Remove spring clip (18) carefully. Remove external thrust bearing (8) and thrust washer (10).

B. Apply downward force to top of drive shaft (60) until it is partially out of the bottom of the body (50) and the octi-cam (1) and internal thrust bearing (8) can be removed. Remove the octi-cam (1) and internal thrust bearing (8). Push the drive shaft (60) completely out of

the bottom of the body (50). If the shaft (60) does not move freely, gently tap with a plastic mallet.

C. Remove the top and bottom shaft bearings (6, 7) and top and bottom shaft o-rings (21, 22). Discard if replacing all soft parts.

6. Cleaning and Inspection:

A. When all components are disassembled, those not being replaced should be properly cleaned and inspected for wear prior to re-assembly.

TABLE 2	
Recommended VPVL Lubricants	
General Use	Dow Corning type Molykote® G-2003
O-Ring Areas	Dow-Corning Silicone 111 (For Standard and High Temperature)
	Parker Super-O-Lube (For LX Option)

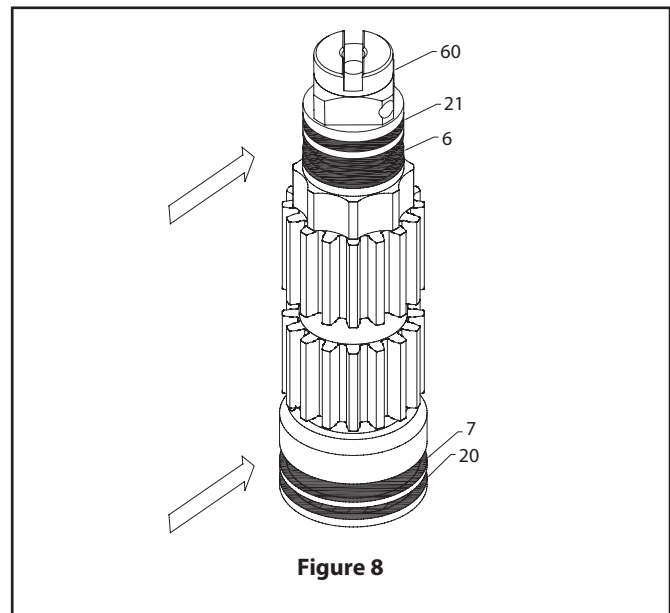

Figure 8

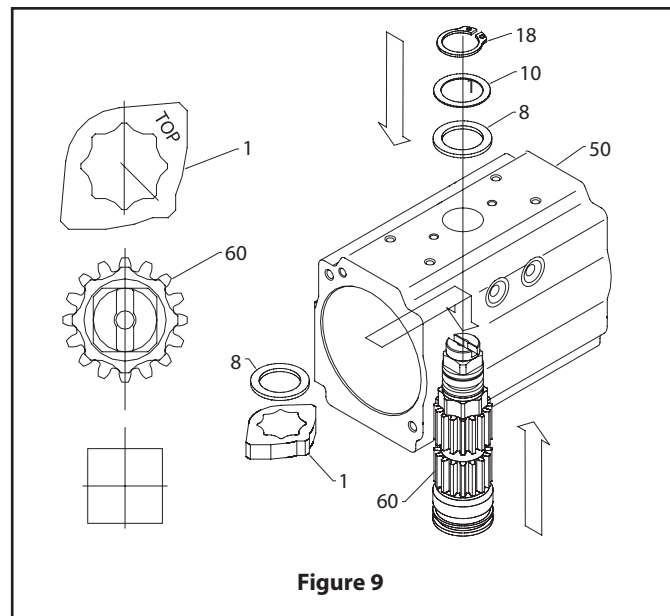

Figure 9

Molykote is the registered trademark of Dow Corning Corporations.

4.3 Assembly

Prior to assembly, ensure that all components are clean and undamaged.

NOTE: (Table 2) lists the recommended *Valv-Powr* lubricants.

1. Drive Shaft (60) Assembly, (Figures 8 & 9):

- A. Install the top and bottom shaft bearings (6, 7) and o-rings (21, 22) onto the shaft (60).
- B. Apply grease to the shaft bearings (6, 7), using a general purpose grease listed in (Table 2). Apply grease to the shaft o-rings (21,22) using the recommended o-ring-area grease listed in (Table 2).
- C. Partially Insert the shaft (60) into the body (50). Install the octi-cam (1) onto the shaft in the orientation shown in (Figure 9). The edges of the octi-cam (1) should align with the edges of the square in the bottom of the shaft (60). Insert the internal thrust bearing (8) over the octi-cam (1). Fully insert the shaft into the body (50).
- D. Install the external thrust bearing (8), thrust washer (10), and the spring clip (18).

2. Piston (40) Assembly, (Figures 10 through 13):

- A. Install the piston o-ring seal (16) and the piston head (15) and piston back (5) bearings.
- B. Apply grease to the internal bore of the body (50) using a recommended o-ring area grease listed in (Table 2). Apply grease to the piston (40) rack teeth using a recommended general purpose grease listed in (Table 2).

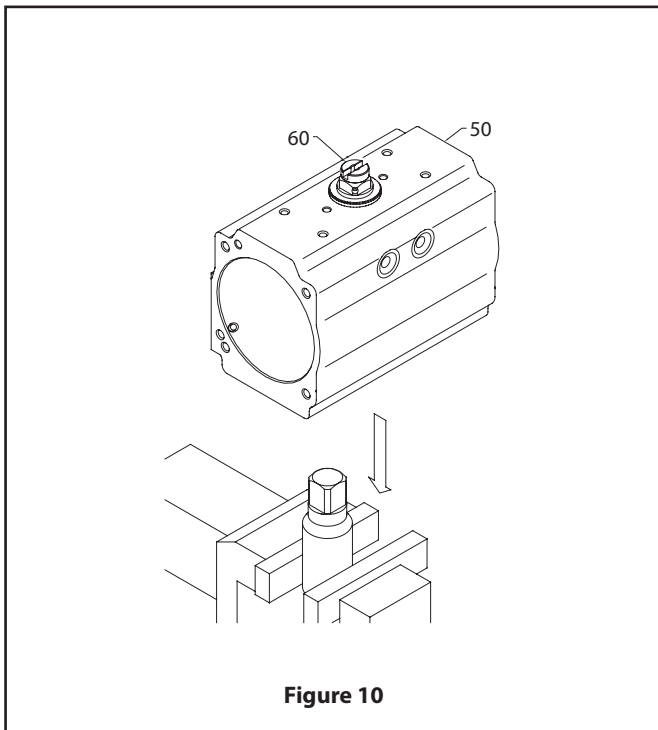

C. Hold the body (50) in a horizontal position by inserting the top of the shaft in a vice, or inserting the bottom of the shaft connection into a male drive fitted into a vice as shown by (Figure 10).

D. Ensure that the octi-cam (1) is in the correct position with respect to the stop screw holes as shown by (Figure 11).

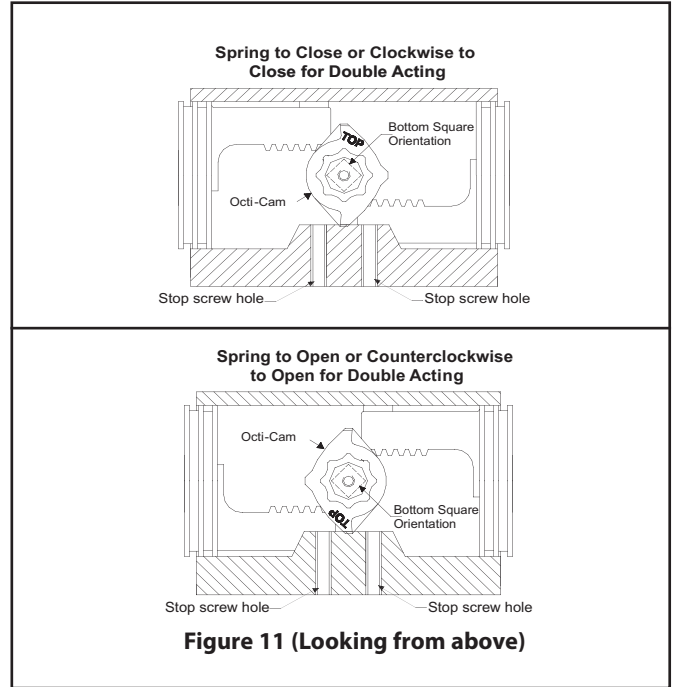

E. For standard-rotation assembly (clockwise to close) rotate the body (50) 40 – 45° counterclockwise (if viewing the bottom of the actuator), or clockwise (if viewing the top of the actuator) as shown in (Figure 12).

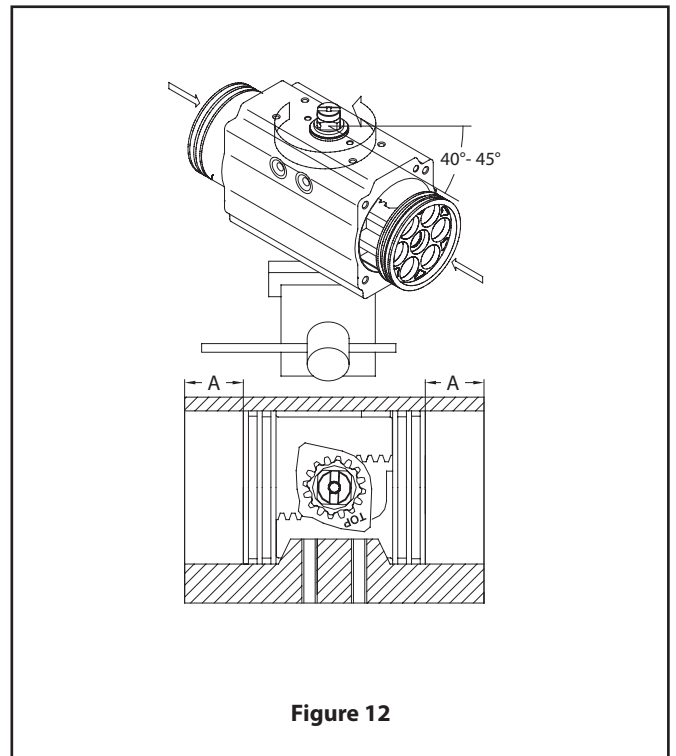

F. Press the two pistons (40) simultaneously into the body (50) until the piston racks are engaged and rotate the body clockwise (if viewing the bottom of the actuator), or counter-clockwise (if viewing the top of the actuator), until the stroke is completed.

G. To ensure that the piston (40) teeth are evenly engaged, fully compress both pistons (40) inward and measure the distance from the edge of the body to the piston (40) face on each side, shown as dimension "A" in (Figure 12). If a different value is obtained on each side, remove the pistons and repeat from step 2d.

H. Temporarily install the position indicator (19) onto the shaft (60) to determine whether the correct stroke is obtained, Verify that the slot in the top of the position indicator (19) will rotate a minimum of 5° beyond the 90° vertical centerline of the actuator body (50) and a minimum of 5° beyond the 0° horizontal centerline of the actuator body as shown in (Figure 13). If the proper stroke is not obtained, remove the pistons and repeat from step 2d. Once the proper stroke is verified, remove the position indicator (19).

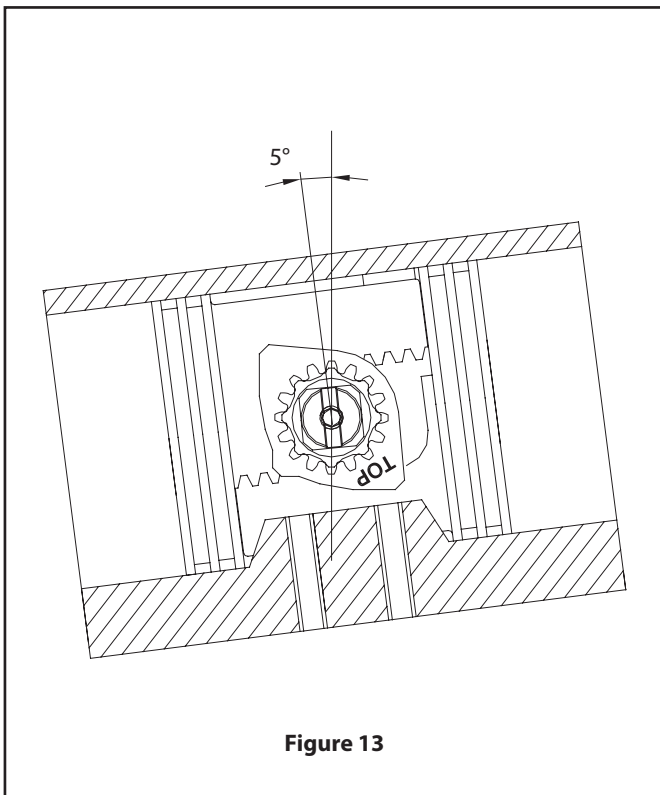

Figure 13

3. End Cap (30) and Spring Cartridge (17) Assembly, (Figures 14 through 16):

A. For spring-return actuators, insert the proper quantity of spring cartridges (17) according to the pattern shown in (Figure 14) (referring to the total number of springs).

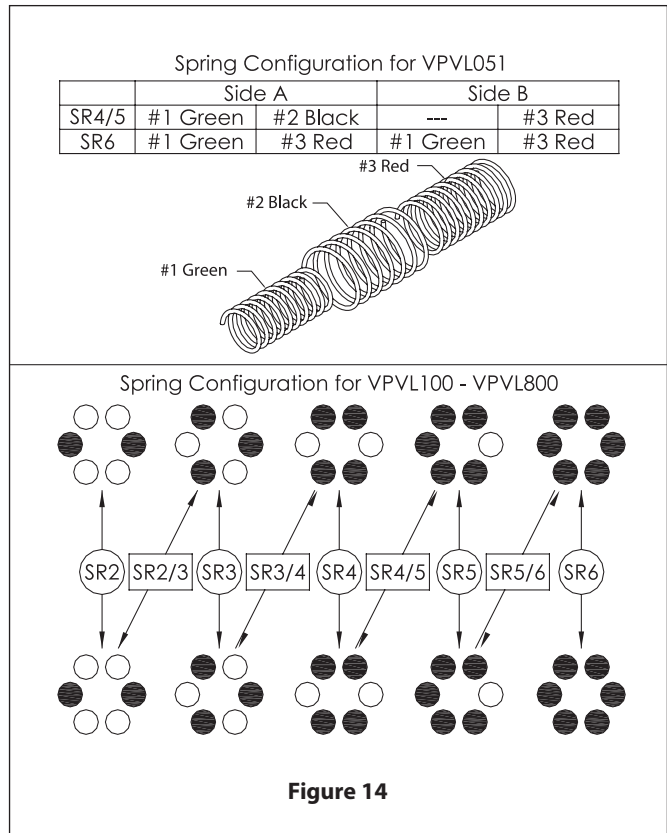

Figure 14

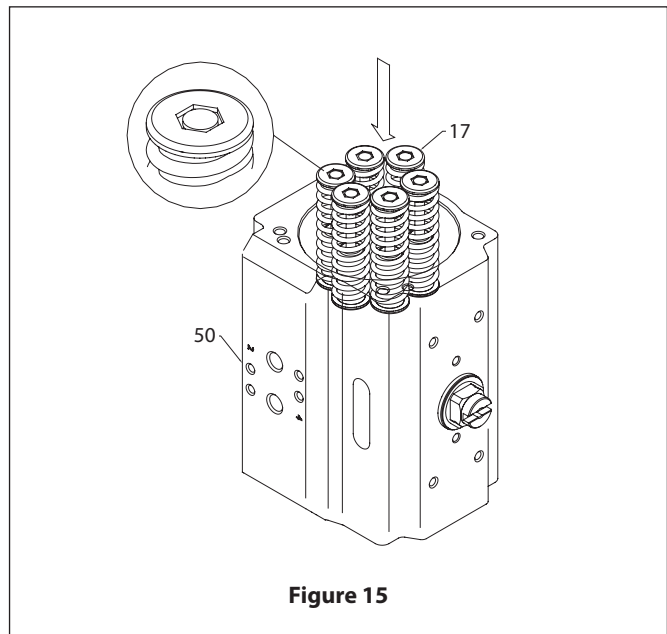

Figure 15

B. Apply grease to the end-cap o-ring seals, using the recommended o-ring-area grease listed in (Table 2). Fit the end-cap o-ring seals (14) into the groove in each end cap (30, 31).

C. Fit the end caps (30) onto the body (50), verifying that the o-ring seals (14) remain in the grooves.

D. Insert all end-cap screws (13) and hand tighten. Complete tightening by following the sequence indicated in (Figure 16), using torques listed in Table 4.

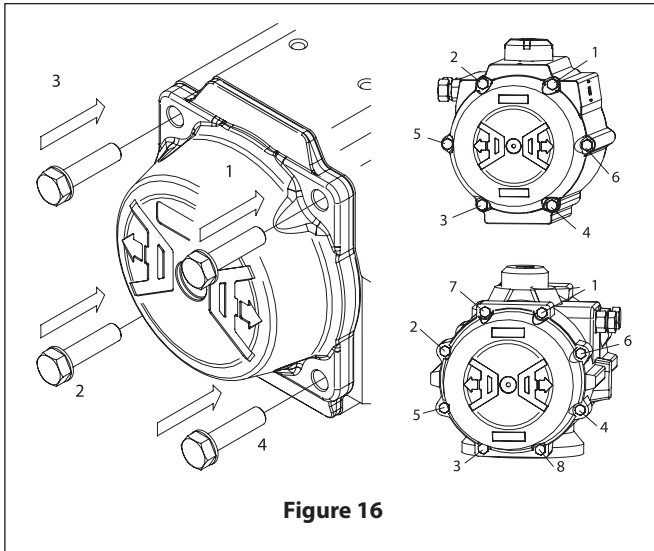

Figure 16

4. Assembly of Stop Screws (2) and Stroke Adjustment. (Figure 17):

- A. Insert the nut (4), washer (3), and o-ring (11) onto the stop screws (2).
- B. Screw the stop screws (2) into the body (50).

5. External Travel Stop Adjustment, (Figure 17):

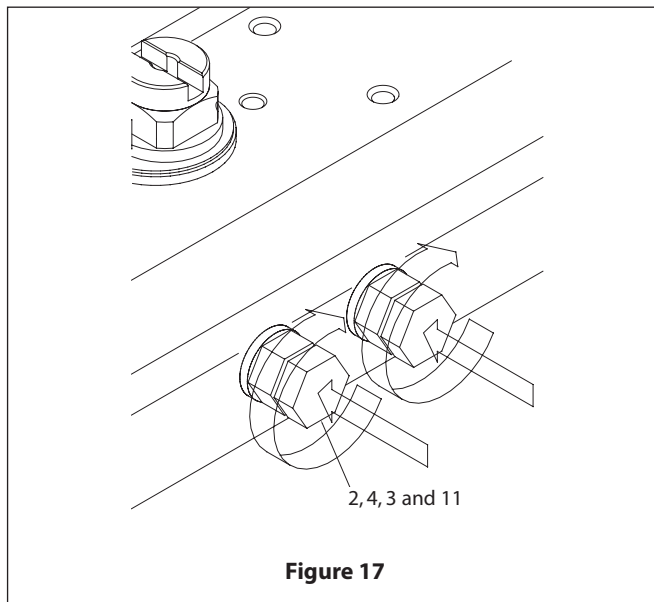

Figure 17

The stop adjustment screw (2) to the right controls the clockwise end of travel. The stop adjustment screw (2) to the left controls the counter-clockwise end of travel.

- A. Cycle the actuator/valve to the clockwise end of travel and measure to determine if the valve is in the proper position. (In most applications this will be fully closed.)
- B. If the valve is not in the correct clockwise position, turn the right stop adjustment screw (2) IN to reduce actuator travel, or OUT to increase actuator travel.

- C. When the correct clockwise position is obtained, hold the adjusting screw (2) stationary while tightening the lock nut (4).
- D. Cycle the actuator/valve to the counter-clockwise end of travel and measure to determine if the valve is in the proper position. (In most applications this will be fully opened.)
- E. If the valve is not in the correct counter-clockwise position, turn the left stop adjustment screw (2) IN to reduce actuator travel, or OUT to increase actuator travel.
- F. When the correct counter-clockwise position is obtained, hold the adjusting screw (2) stationary while tightening the lock nut (4).

6. Position Indicator (19, 39) Assembly. (Figure 18):

- A. Fit position indicator (19) on the shaft (60), verifying that it indicates the correct actuator position.
- B. Tighten cap screw (39) to secure the position indicator.

7. Setting 100% Adjustable Stop (If applicable). (Figure 19):

To limit the rotation on the stroke beyond the standard $\pm 5^\circ$ of a VPVL actuator, a stainless steel 100% adjustable travel stop option can be added. The stops, located in the end caps, allow the valve position to be set anywhere between full closed and full open. This option limits travel of only the counter-clockwise stroke for standard double-acting and spring-closed units. Follow the proceeding steps in order to set the 100% adjustable travel stops.

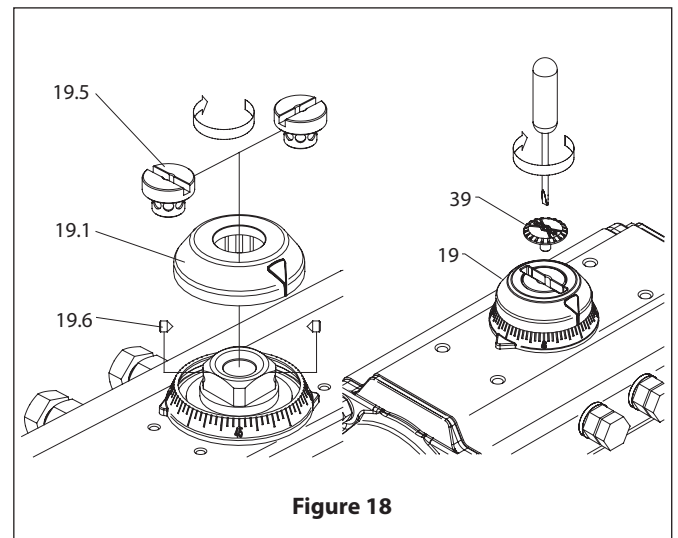

Figure 18

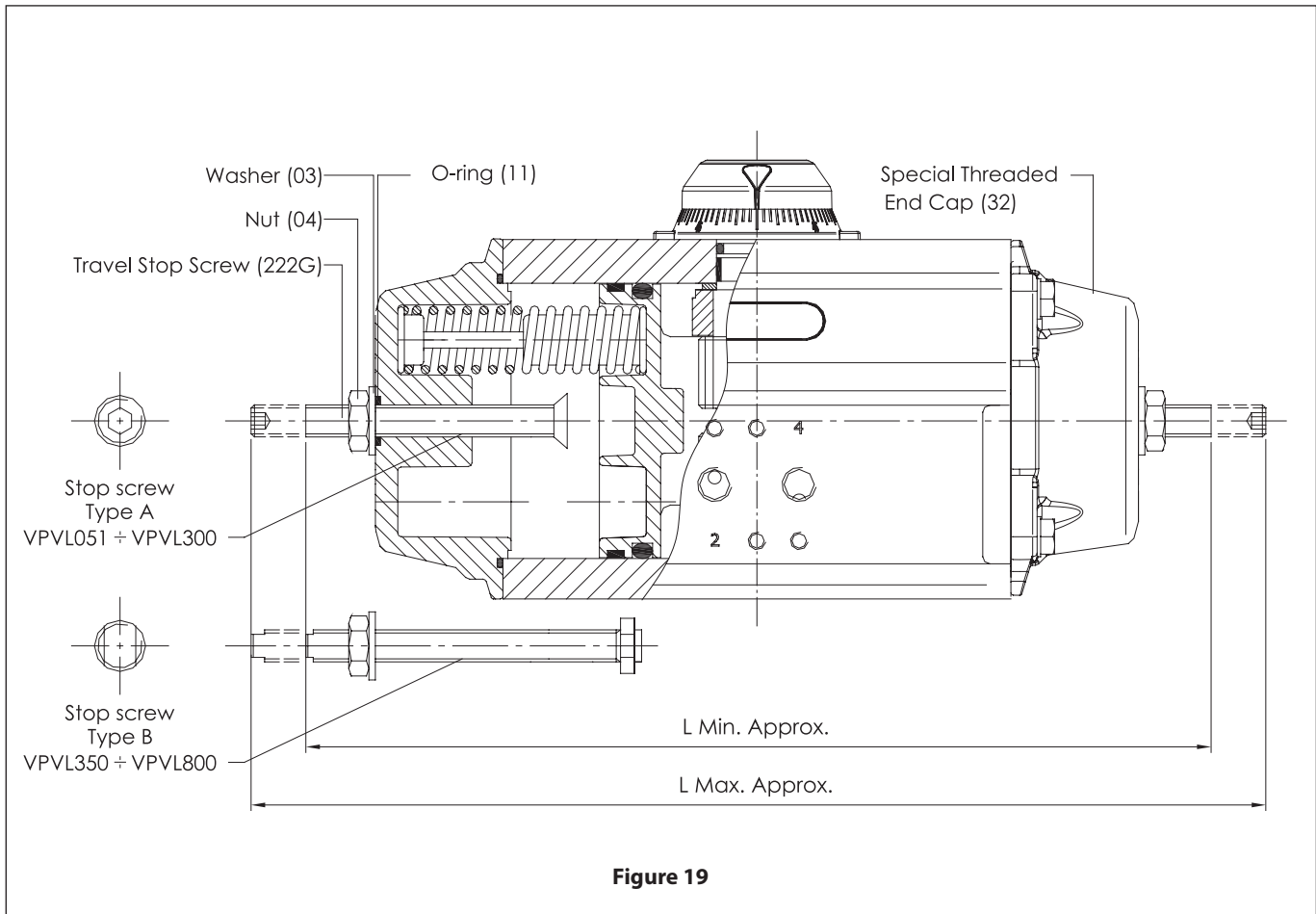

Figure 19

Double Acting Actuators:

- A. Back off one travel stop screw, leaving it partially threaded in the end cap. Entirely remove the other travel stop screw from the other end cap.
- B. Open valve using air pressure. **NOTE:** Actuator will leak due to removed travel stop.
- C. Use the indicator pointer on top of actuator to determine if valve is open to desired position. If not, repeat steps 1-3, backing off or screwing in stop screw to attain proper open position of valve.
- D. Make sure O-ring is in proper position in countersunk area on end cap and the washer is in place. Tighten down nut to set stop position.
- E. Thread in the other travel stop, making sure the O-ring and washer are in the correct place. When the travel stop will not thread any further, tighten nut to set stop position.
- F. The previous steps set the open travel stop. See **section 4.3.5** for instructions on setting the close position stop.

Spring Return Actuators:

- A. Back off one travel stop screw, leaving it partially threaded in the end cap. Entirely remove the other travel stop screw from the other end cap.

- B. Open valve using air pressure. Note actuator will leak due to removed travel stop.
- C. Keeping air pressure applied to actuator, use the indicator pointer on top of actuator to determine if valve is open to desired position. If not, remove air pressure and repeat steps 1-3, backing off or screwing in stop screw to attain proper open position of valve.
- D. Make sure O-ring is in proper position in countersunk area on end cap and the washer is in place. Tighten down nut to set stop position.
- E. Thread in the other travel stop, making sure the O-ring and washer are in the correct place. When the travel stop will not thread any further, tighten nut to set stop position.
- F. The previous steps set the open travel stop. See **section 4.3.5** for instructions on setting the close position stop.

5. SAFETY LOCKOUT DEVICE

WARNING:

IF THE SERIAL NUMBER OF THE ACTUATOR IS 10136023 OR LOWER THEN THE ACTUATOR MUST BE DISASSEMBLED AND THE OCTI-CAM (1) MUST BE ROTATED, SEE **FIGURE 9**, BEFORE INSTALLING THE SAFETY LOCKOUT KIT.

1. Removal of Stop Screws:

- A. Remove from the Body both the existing Standard Stop Screws (02) together with Nut (04), Washer (03) and the O-ring (11), see **(Figure 4)**.

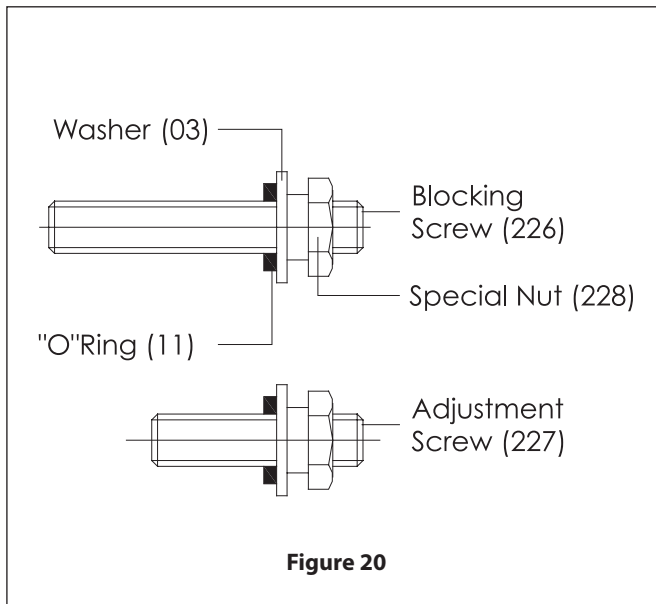

Figure 20

- B. Insert on the Adjustment Screw (227) and on the Blocking Screw (226) the Special Nut (228), the Washer (03) and the O-ring (11), see **(Figure 21)**.

2. Assembly of Blocking Screw and Adjustment Screw:

- A. Before proceeding with the assembly of the Adjustment and Blocking Screws in the body, check the requested stop position. If the stop position is fully close (0°) or fully open (90°), **Figure 21**. Attention: when the screws are fitted, the actuator position must be $0^\circ \pm 2^\circ$ or $90^\circ \pm 2^\circ$.

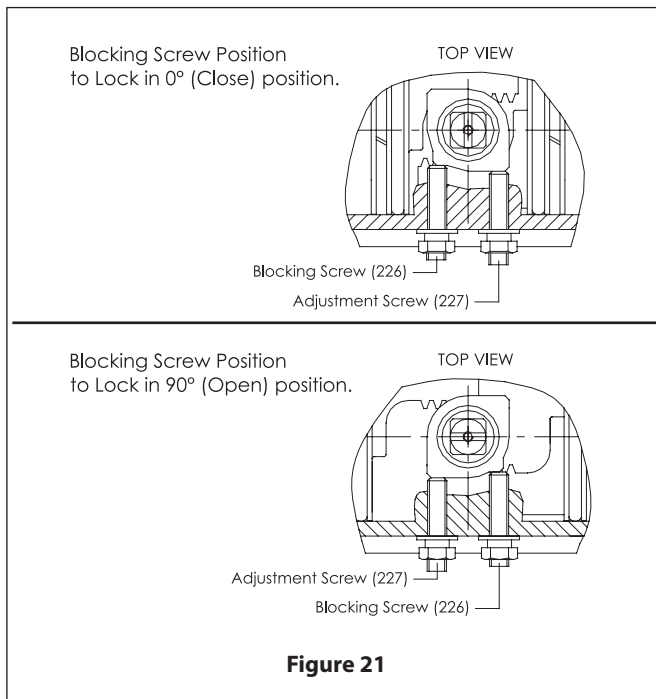

Figure 21

- B. Insert the Blocking Screw (226) and the Adjustment Screw (227) into the Actuator Body until the desired lock position is achieved then tighten the Special Nut (228), see **(Figure 21)**.

WARNING:

THE LOCK OUT FEATURE CAN BE RENDERED INEFFECTIVE BY A MIS-ALIGNED OCTI-CAM (**SEE FIGURE 11**) WHICH COULD CAUSE DAMAGE TO EQUIPMENT OR PERSONAL INJURY! FUNCTIONAL TESTING IS RECOMMENDED ON INITIAL INSTALLATION OF LOCKING DEVICES AND AFTER ANY SERVICE OR REPAIR TO CONFIRM THE EFFECTIVENESS OF THE LOCK OUT FEATURE.

- C. After engaging the stop, functionally test the locked position of the actuator by applying full pressure to the unit against the engaged stop to confirm that the stop is effective.

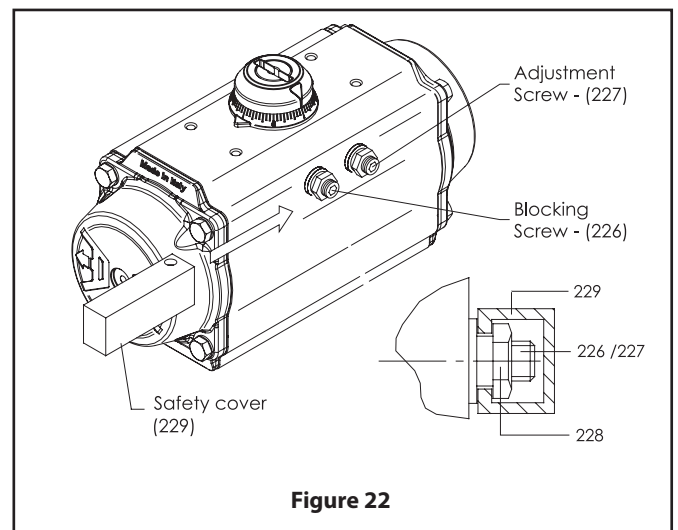

Figure 22

3. Assembly of Safety Cover and Padlock:

- A. Insert the Safety Cover (229) between the Special Nuts (228) and Washer (03) as shown in **(Figure 22)**.
- B. Then insert in the hole of the Safety Cover the Padlock (230) and lock it.
- C. For safety reasons keep the Padlock key in a safe place.

6. Declutchable Manual Override (DO)

The DO_ is a declutchable manual override quarter turn gearbox for single/double acting pneumatic actuators. To prevent damage, it must be ensured that the actuator is not operating, or able to operate, the gearbox when switching from auto to manual or when operating the gearbox in manual mode. **NOTE:** The following instructions reference a fail closed (clockwise to close) installation, but a fail open installation is also possible.

6.1 Installation

1. It is recommended to mount the handwheel on the input shaft prior to assembling the gearbox to the valve.
2. Verify that the flanges on the gearbox and valve align. Also verify that the valve stem and the bore of the gearbox driveshaft match.
3. Make sure the valve is in the fully closed position.
4. Make sure that the gearbox is in the fully closed position (as standard from the factory). This is achieved by turning the handwheel clockwise.
5. Screw the stud bolts into the bottom flange of the gearbox prior to mounting the gearbox on top of the valve.

NOTE: use of a gasket/sealant on the flanges between the valve/ gearbox and between the gearbox/actuator is recommended.

6. Mount the gearbox perpendicular to the valve and secure the fasteners.
7. Follow the "Stop screw adjustment" procedure.
8. Position the driveshaft on top of the gearbox
9. Mount the actuator on top of the gearbox.

6.2 Stop screw adjustment

1. Remove air from the actuator and ensure the valve/ actuator/gear are in the fully closed position.
2. Put the gearbox in manual-mode by turning the handle counter clockwise as shown in **Figure 23** below. First pull the knob (1) then turn the selector (2) and then release the knob (3) and make sure it is engaged.
3. Turn the handwheel clockwise to put the gearbox/ valve in the fully closed position. When the fully closed position cannot be achieved, loosen the stop screw-close on the gearbox (**Figure 23**) and check the travel stop adjustment of the actuator. Once fully open is achieved, hand tighten the stop screw and secure with the lock nut.
4. Turn the handwheel counter clockwise to put the gearbox/valve in the fully opened position. When the fully open position cannot be achieved, loosen the stop screw-open on the gearbox (**Figure 23**) and check the travel stop adjustment of the actuator. Once fully open

is achieved, hand tighten the stop screw and secure with the lock nut.

5. Pull the knob outwards (3) then turn the selector (2) toward auto until the knob falls back into its locked position. The gearbox is now ready for operation.

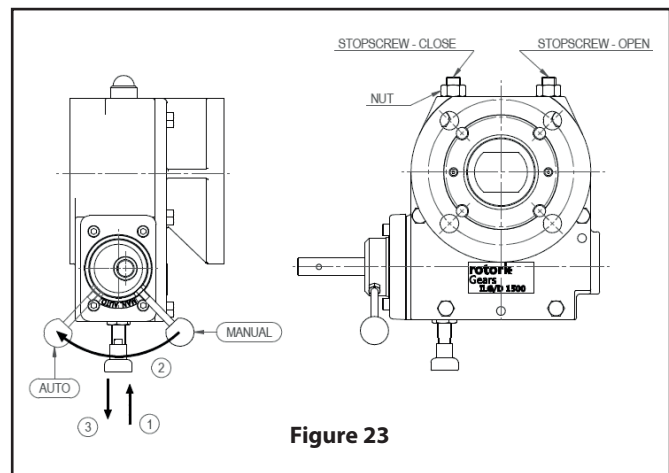

Figure 23

6.3 Operation

1. The gearbox is delivered in automatic mode where the valve is operated by the actuator.
2. To operate the valve with the handwheel, the gearbox must be put into manual mode. Refer to **Figure 23**:
 - a. Vent the supply air from the actuator. Depending on the instrumentation configuration there are multiple ways to achieve this, 2 examples:
 - i. Adjust the supply regulator to zero
 - ii. Use the solenoid manual operator to exhaust the air from the spring side of a single acting actuator. i.e. ASCO 8551 solenoids with 'MO'/'MS', rotate the manual operator screw from '0' to '1'.
 - b. Pull the knob outwards (3) and hold the knob in this position.
 - c. Turn the handle counter clockwise (2) toward "AUTO" and release the knob. Continue turning the handle until the knob falls back into locking position (1).
 - i. **NOTE:** When the handle cannot be fully turned $\pm 90^\circ$, turn the handwheel slightly. Continue turning the handle until full engagement is achieved (knob returns to start position).
 - d. The gearbox is ready for manual operation.
 - e. Turn the handwheel clockwise to close the valve or counter-clockwise to open the valve. The number of turns needed to move from totally open to totally closed is at least 8 turns and varies by model.
3. Declutch the gearbox to return to automatic mode:
 - a. Pull the knob outwards (3) and hold the knob in this position.

- b. Turn the handle clockwise (2) toward "MAN" and release the knob. Continue turning the handle until the knob falls into its locked position (1).
- c. If item 2.a applies, return the supply air to the actuator. i.e. re-set the regulator pressure or close the solenoid manual operator (i.e. rotate the screw from 1 to 0).

7. ACTUATOR STORAGE

1. If the actuators are not for immediate use, the following precautions must be taken for storage:
 - A. Store in a dry environment
 - B. It is recommended that the actuator be stored in its original box.
 - C. Do not remove the plastic plugs on the air supplyports.

8. SERVICE / SPARE PARTS

We recommend that actuators be directed to our service centers for maintenance. The service centers are equipped to provide rapid turn-around at a reasonable cost and offer new actuator warranty with all reconditioned actuators.

NOTE: When sending goods to the service center for repair, do not disassemble them. Clean the actuator prior to shipping.

For further information on spare parts and service or assistance visit our web-site at www.neles.com/valves.

NOTE: When ordering spare parts, always include the following information:

- A. Actuator catalog code from label,
- B. If the actuator is serialized – the serial number (from identification plate)
- C. From **Figure 24**, the ballooned part number, part name and quantity required.

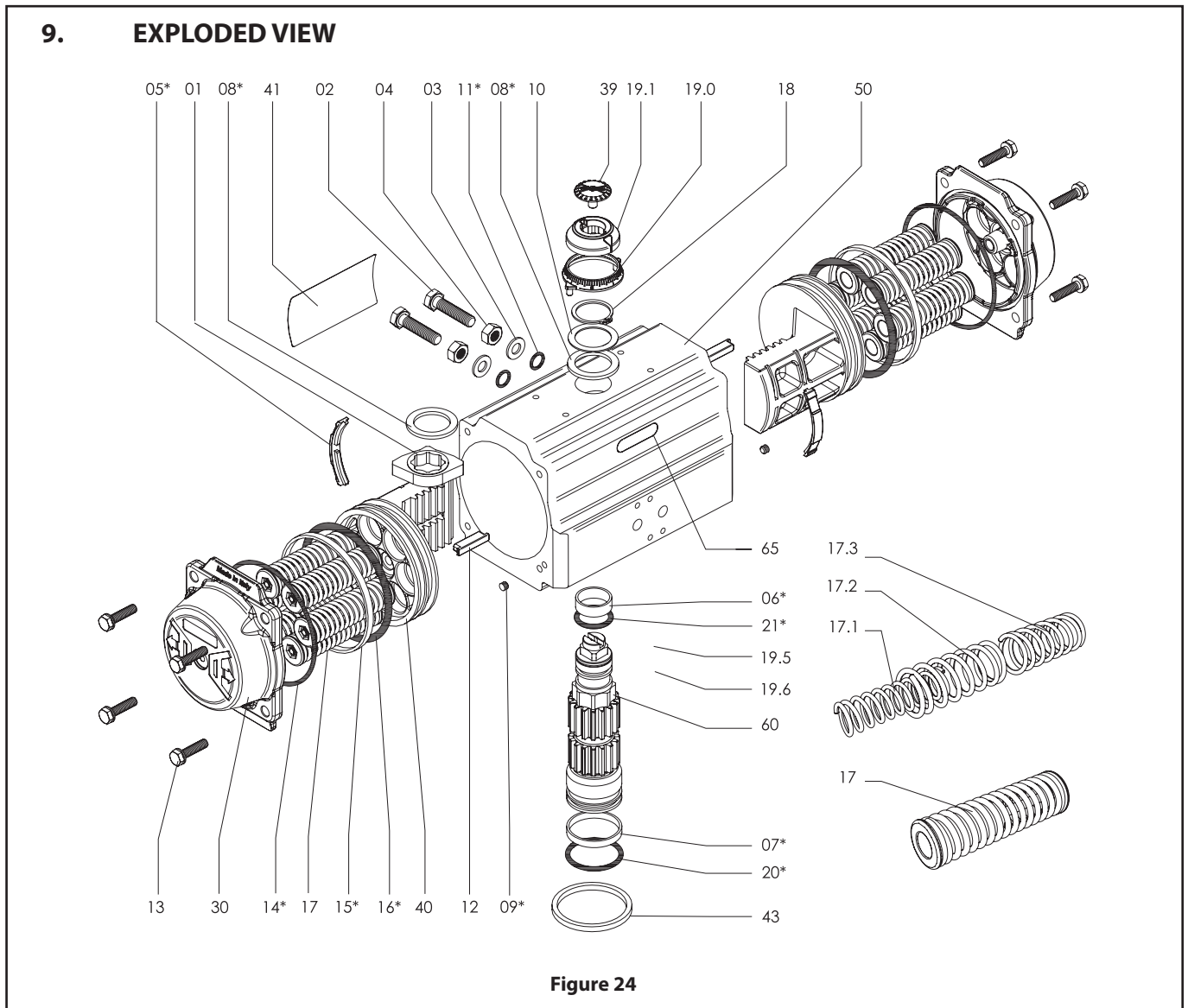

TABLE 3 - PARTS LIST FOR (FIGURE 24)			
Part #	Qty	Part Description	Material
1	1	Octi-Cam (Stop Arrangement)	Stainless Steel / Carbon Steel (1)
2	2	Stop Cap Screw	Stainless Steel
3	2	Washer (Stop Cap Screw)	Stainless Steel
4	2	Nut (Stop Cap Screw)	Stainless Steel
5 x	2	Bearing (Piston Back)	High Grade Polymer
6 x	1	Bearing (Pinion Top)	High Grade Polymer
7 x	1	Bearing (Pinion Bottom)	High Grade Polymer
8 x	2	Thrust Bearing (Pinion)	High Grade Polymer
9 xy	2	Plug (Transfer Port)	Silicone
10	1	Thrust Washer (Pinion)	Stainless Steel
11 xy	2	O-ring (Stop Cap Screw Seal)	Special NBR
12	2	Piston Guide	High Grade Polymer
13	8/12/16/ (2)	Cap Screw (End Cap)	Stainless Steel
14 xy	2	O-ring (End Cap)	Special NBR
15 x	2	Bearing (Piston Head)	High Grade Polymer
16 xy	2	O-ring (Piston)	Special NBR
17	min. 5/ max.12	Spring (Cartridge)	Alloy Steel - Epoxy Coated
18	1	Spring Clip (Pinion)	Spring Steel - ENP
19.0	1	Graduated Ring	High Grade Polymer
19.1	1	Position Indicator	High Grade Polymer
19.5	1	Top Adaptor	Extruded Aluminum - Anodized
19.6	2	Hex Socket Set Screw	Stainless Steel
20 xy	1	O-ring (Pinion Bottom)	Special NBR
21 xy	1	O-ring (Pinion Top)	Special NBR
30	2	End Cap	Cast Aluminum - Anodized - Coated
39	1	Cap Screw (Indicator)	High Grade Polymer
40	2	Piston	Cast Aluminum - Anodized - Coated
41	1	Actuator Identification Label	Polyester Aluminum
50	1	Body	Extruded Aluminum - Anodized - Coated
60	1	Drive Shaft	Carbon Steel Plated
65	1	Plastic Insert	High Grade Polymer

Spare parts for maintenance

x - Included in Complete Kit

y - Included in O-ring Kit

Notes: (1) AISI304 for models VPVL-051 through 300; Carbon Steel for models VPVL-350 through 800

(2) Qty 8 pieces for models VPVL-051 through 600; Qty 12 pieces for model VPVL-700 and Qty 16 pieces for model VPVL-800.

TABLE 4**VPVL END CAP TORQUE VALUES**

	End Cap	Metric	Torque					
	Bolt Size	Wrench Size	in-lbs		ft-lbs		N-m	
VPVL051	M5	8	44	53			5	6
VPVL100	M6	10	89	97			10	11
VPVL200	M6	10	89	97			10	11
VPVL250	M6	10	89	97			10	11
VPVL300	M8	13			17	18	23	24
VPVL350	M8	13			17	18	23	24
VPVL400	M10	17			35	38	47	52
VPVL450	M10	17			35	38	47	52
VPVL500	M12	19			60	63	81	85
VPVL550	M12	19			60	63	81	85
VPVL600	M14	22			97	102	132	138
VPVL650	M16	24			148	155	201	210
VPVL700	M14	22			97	102	132	138

WARNING:

As the use of the actuator is application specific, a number of factors should be taken into account when selecting an actuator for a given application. Therefore, some of the situations in which the actuators are used are outside of the scope of this manual. If you have any questions concerning the use, application or compatibility of the actuator with the intended service, contact Neles for more information.

HOW TO ORDER

To specify a complete *Valv-Powr* Value-Line® Actuator, simply make a selection from the code boxes below.

EXAMPLE: VPVL 400 SR4/5 B AS D, shown below, is a 59 FT•LBS 60-psi (84 N•m @ 4.2 bar) spring-return actuator with spring-to-close rotation, hard-anodized PTFE-coated body, polyester-coated end caps, standard temperature rating, and 100% adjustable travel stops.

1	2	3	4	5	6	7
VPVL	400	SR4/5	B	AS	D	—

NOTE: for multiple options, specify them in order as listed in Item 5, for example: VPVL400 SR4/5 B HT AS Model D.

1	Product Group
VPVL	<i>Valv-Powr</i> Double-opposed Piston Actuator

2	Size
051	Select from torque table
100,200	
250,300	
350, 400	
450, 500	
550, 600	
650, 700	
800	

3	Series+
DA	Double acting, pneumatic
SR4/5	Spring-Return 60-psi (4.1 bar) Spring-to-Close (CW Rotation)
SR6	Spring-Return 80-psi (5.5 bar) Spring-to-Close (CW Rotation)

+ Other spring rates on application

4	Exterior Protection*
B	Hard-Anodized PTFE-Coated Body & Polyester-Coated End Caps

* Consult factory for other protection options.

5	Options
—	Standard Temperature Rating: -40°F to +176°F (-40°C to +80°C)
HT†	High-Temperature Rating: +5°F to +302°F (-15°C to +150°C)
LX†	Low-Temperature Rating: -60°F to +176°F (-51°C to +80°C)
FO	Spring-to-Open (CCW Rotation)
AS	100% Travel Stop
LD	Mechanical Safety Lockout

† HT and LX options decrease cycle life.

6	Model
D	Model D

7	Modifier Code
—	Standard

Subject to change without prior notice. Neles, Jamesbury and Easyflow by Neles, and certain other trademarks, are either registered trademarks or trademarks of Neles Corporation or its subsidiaries or affiliates in the United States and/or in other countries. For more information www.neles.com/trademarks

Neles

Vanha Porvoontie 229, 01380 Vantaa, Finland.
Tel. +358 10 417 5000.

neles.com

Reinventing
reliability