

# NELES

## Compact rack and pinion pneumatic actuator

### Jamesbury™ Valv-Powr™ VPVL series model D

The Jamesbury™ Valv-Powr – VPVL double-opposed piston actuators combine the benefits of high cycle life, a rugged construction, and an extremely compact and symmetrical design with a unique range of features and options. They are specifically designed for fast efficient operation of ball, butterfly, and other rotary type valves.

#### FEATURES

##### Single-Source Responsibility

- Valves, actuators, and accessories are designed to operate as a unit with the highest degree of compatibility.
- Valves, actuators, and accessories can be supplied completely assembled to provide unit responsibility from a single source.

##### Versatility

- Modular designs with same body and end caps for double-acting and spring-return. Springs can be added in the field to convert double-acting to spring-return or for changes in supply pressure.
- Failure direction can be easily reversed from spring-to-open or spring-to-close orientation simply by inverting the pistons.
- Actuator to valve attachments comply with ISO 5211.
- Solenoid valve and accessory attachments comply with NAMUR VDI/VDE 3845.
- A wide range of optional accessories and control devices that include limit switches, solenoid valves, and mechanical safety lockouts are available to satisfy virtually all automated valve requirements.

##### High Cycle Life

- Bearings on all sliding and rotating moving parts to ensure long life.
- Dual piston rack-and-pinion mechanism for simple construction, high cycle life, and constant torque.
- Body and end caps with honed internal surface for strength and lower coefficient of friction.

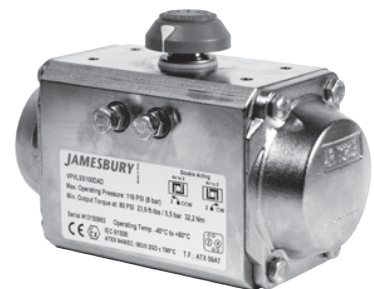

- Mechanically multi-guided aluminum pistons for precise movement, low friction, and high cycle life.
- Machined teeth on piston racks and pinions for excellent rack and pinion engagement and maximum efficiency.

##### Corrosion Resistant

- Hard-anodized PTFE-coated body, polyester-coated end caps, and epoxy-coated springs, along with internal and external stainless steel fasteners, provide corrosion resistance in a variety of difficult applications and environments.
- Optional forged stainless steel model designed for use in corrosive environments. Constructed of A182 F316/EN 10088/3 1.4401 quality stainless steel and epoxy-coated springs, along with internal and external stainless steel fasteners, provide corrosion resistance in a variety of difficult applications and environments.

Typical applications include:

- Pharmaceutical
- Sanitary
- Food Industry
- Marine and Offshore

### Reliability

- Safety-contained multi-spring design with preloaded and heavy-duty coated springs for simpler range versatility, greater safety, and corrosion resistance.
- External adjustable stops in both directions assure flexibility and accuracy when setting the valve in the open and closed positions.
- As an added safety feature, the external adjustment screws are designed to start venting internal pneumatic pressure in the actuator before the screw is fully backed out. The sound of escaping pressure indicates an unsafe condition.

### SPECIFICATIONS

Maximum Supply Range: 116 psi (8 bar)

Temperature Range:

Standard	-40°F to +176°F (-40°C to +80°C)
High Temp	5°F to +302°F (-15°C to +150°C)
Low Temp	-60°F to + 176°F (-51°C to + 80°C)

Rotation Adjustment: Close -5° to +5° from 0°  
Open +5° to -5° from 90°

Protection class: IP67, IP68M

Supply Media: Air, Nitrogen

Air Quality:

Acc. to ISO 8573-1

Solid particles: Maximum particle size 30 µm

Humidity: Dew point equal to -20°C or 10°C/  
18°F below ambient temperature

### STANDARDS

Actuator to valve mounting: ISO 5211

Actuator to solenoid mounting: Namur, VDI/VDE3845\*

Actuator to accessory mounting: Namur, VDI/VDE3845

Approved to ATEX 2014/34/EU Directive:

- Standard/Low Temperature:

- II 2 G Ex h IIB or IIC T6..T5 GB X

- II 2 D Ex h IIIC T85°C...T95°C Db X

- High Temperature:

- II 2 G Ex h IIB or IIC T6..T3 GB X

- II 2 D Ex h IIIC T85°C...T165°C Db X

TUV Rheinland certified according to IEC61508 to be used in safety applications up to and including safety integrity level 3 (SIL 3).

\* VPVL051 - 600 = NAMUR 1/4"

VPVL650 - 800 = NAMUR 1/2"

### ACTUATOR SELECTION

To select an actuator for a particular valve and service, first determine the maximum operating torque that will be required from the applicable valve bulletin. Then refer to the appropriate torque output table and select an actuator that will, at the available supply pressure, provide a torque output no less than the required operating torque for the

valve. For spring-return units, both the spring torque and the air torque must exceed the required operating torque for the valve. If you have any question that the actuator selected meets your intended service requirement, contact Neles. Contact information is located on last page of this technical bulletin.

Actuator Model	Air Volume							Bore Diam.		Moving Time		Weight	
	in. <sup>3</sup>			ml			Seconds <sup>1</sup>						
	Opening	Closing	Swept	Opening	Closing	Swept	in.	mm	Opening	Closing	lb.	kg	
VPVL051	DA	5.5	9.2	3.4	90.1	150.8	55.5	1.97	50	0.2	0.3	2.2	1.0
	SR		-										
VPVL100	DA	9.8	15.9	6.0	160.6	260.6	97.8	2.48	63	0.3	0.3	3.5	1.6
	SR					-							
VPVL200	DA	18.9	29.9	11.8	309.7	490	194.1	2.95	75	0.3	0.4	6.0	2.7
	SR					-							
VPVL250	DA	31.1	47.6	18.6	509.6	780	305.4	3.46	88	0.4	0.5	8.2	3.7
	SR					-							
VPVL300	DA	43.3	67.7	27.1	709.6	1109	443.7	3.94	100	0.5	0.7	11.5	5.2
	SR					-							
VPVL350	DA	72.6	109.8	43.8	1190	1799	717.2	4.53	115	0.7	0.9	17.6	8.0
	SR					-							
VPVL400	DA	94	143	56	1540	2443	924	4.92	125	0.9	1.2	21.6	9.8
	SR					-							
VPVL450	DA	147	231	89	2409	3765	1451	5.71	145	1.2	1.5	31.3	14.2
	SR					-							
VPVL500	DA	192	300	116	3146	4916	1893	6.30	160	1.5	1.8	39.9	18.1
	SR					-							
VPVL550	DA	260	420	156	4261	6883	2556	7.09	180	2.0	2.4	53.6	24.3
	SR					-							
VPVL600	DA	362	577	217	5932	9455	3549	7.87	200	2.7	3.5	75.2	34.1
	SR					-							
VPVL650	DA	610	928	364	10000	15200	5963	9.45	240	3.5	4.1	116	52.7
	SR					-							
VPVL700	DA	885	1305	528	14503	21385	8655	10.43	265	4.0	4.5	163	74.0
	SR					-							
VPVL800	DA	1526	2441	917	25000	40000	15032	12.99	330	6.0	7.0	280	127.0
	SR					-							

#### NOTES:

(1) The above times are based on the following conditions: A) Room temperature, B) Solenoid valve orifice diameter of 4 mm (5/32 in.) and a flow rate capacity of 400 L/min (14.1 cfm), C) Minimum inner piping diameter of 8 mm (5/16 in.), D) 5.5 bar (80 psi) air supply pressure, E) Without valve loading.

## ACTUATOR SELECTION (CONTINUED)

### SPRING RETURN

Actuator Model	Spring-Return Torque Output		Air Torque Output at Specified Supply Pressure			
	FT-LBS	N-m	FT-LBS, @ 60 psi	N-m @ 4.2 bar	FT-LBS @ 80 psi	N-m @ 5.5 bar
051 SR4/5	4.4	5.9	3.2	4.4	-	-
051 SR6	5.8	7.9	-	-	4.4	6
100 SR4/5	7.4	10	6.9	9.4	-	-
100 SR6	9.8	13.3	-	-	8.8	12
200 SR4/5	14.7	19.9	13.1	17.7	-	-
200 SR6	19.5	26.5	-	-	16.5	22.4
250 SR4/5	24.3	33	18.4	24.9	-	-
250 SR6	32.4	44	-	-	23.2	31.4
300 SR4/5	33.6	45.6	30.1	40.8	-	-
300 SR6	44.8	60.8	-	-	38.1	51.7
350 SR4/5	54.4	73.8	46.2	62.6	-	-
350 SR6	72.6	98.4	-	-	58.4	79.2
400 SR4/5	69.7	94.5	62.2	84.3	-	-
400 SR6	92.9	126	-	-	78.9	107
450 SR4/5	109.1	148	98.1	133	-	-
450 SR6	146.0	198	-	-	124.6	169
500 SR4/5	149.0	202	131.3	178	-	-
500 SR6	198.4	269	-	-	165.9	225
550 SR4/5	210.2	285	160.0	217	-	-
550 SR6	279.5	379	-	-	202.1	274
600 SR4/5	282.4	383	241.2	327	-	-
600 SR6	376.1	510	-	-	305.3	414
650 SR4/5	478.6	649	415.2	563	-	-
650 SR6	637.9	865	-	-	527.3	715
700 SR4/5	724.2	982	543.5	737	-	-
700 SR6	965.3	1309	-	-	686.6	931
800 SR4/5	1221.2	1656	1146.8	1555	-	-
800 SR6	1627.6	2207	-	-	1462.4	1983

### DOUBLE ACTING

Actuator Model	Torque Output in Ft-lbs - Double Acting Actuator at Specified Supply Pressures						
	40 psi	50 psi	60 psi	70 psi	80 psi	90 psi	100 psi
VPVL 051	6.8	8.4	10.2	11.8	13.5	15.3	16.9
VPVL 100	11.9	14.9	17.9	20.9	23.8	26.8	29.8
VPVL 200	23.7	29.6	35.5	41.4	47.3	53.3	59.2
VPVL 250	37.3	46.6	55.8	65.2	74.5	83.8	93.1
VPVL 300	54.1	67.6	81.2	94.7	108.2	121.8	135.3
VPVL 350	87.4	109.3	131.2	153.0	174.9	196.8	218.6
VPVL 400	112.7	140.9	169.1	197.3	225.4	253.6	281.8
VPVL 450	176.9	221.2	265.4	309.7	353.8	398.1	442.3
VPVL 500	230.8	288.5	346.3	403.9	461.7	519.3	577.1
VPVL 550	311.6	389.5	467.4	545.3	623.3	701.1	779.0
VPVL 600	432.8	541.0	649.2	757.3	865.6	973.8	1082.0
VPVL 650	727.1	908.8	1090.6	1272.4	1454.2	1635.9	1817.7
VPVL 700	1055.3	1319.1	1582.9	1846.8	2110.6	2374.4	2638.3
VPVL 800	1832.8	2291.1	2749.3	3207.5	3665.7	4123.9	4582.1

Actuator Model	Torque Output in N-m - Double Acting Actuator at Specified Supply Pressures						
	2.7 bar	3.5 bar	4.2 bar	4.8 bar	5.5 bar	6.2 bar	6.9 bar
VPVL 051	9.2	11.4	13.8	16.0	18.3	20.7	22.9
VPVL 100	16.2	20.2	24.3	28.4	32.3	36.4	40.4
VPVL 200	32.1	40.1	48.1	56.2	64.2	72.2	80.2
VPVL 250	50.5	63.2	75.7	88.4	101.0	113.5	126.2
VPVL 300	73.3	91.6	110.0	128.3	146.7	165.1	183.4
VPVL 350	118.5	148.2	177.8	207.4	237.2	266.8	296.4
VPVL 400	152.8	191.1	229.2	267.4	305.6	343.8	382.0
VPVL 450	239.9	299.9	359.9	419.8	479.7	539.7	599.7
VPVL 500	313.0	391.1	469.4	547.6	625.9	704.1	782.4
VPVL 550	422.4	528.1	633.7	739.4	845.0	950.5	1056.2
VPVL 600	586.7	733.5	880.1	1026.8	1173.6	1320.2	1467.0
VPVL 650	985.8	1232.2	1478.6	1725.1	1971.6	2218.0	2464.4
VPVL 700	1430.7	1788.4	2146.1	2503.8	2861.5	3219.2	3576.9
VPVL 800	2485.0	3106.3	3727.4	4348.7	4969.9	5591.2	6212.4

## OPTIONS

### Solenoid Valves

Direct-mounted solenoid valves are available in both 3-way and 4-way configuration, which mount directly to the actuator in accordance with NAMUR and VDI/VDE 3845 standards, excluding the VPVL650, 700 and 800. In general, 3-way solenoids are used for spring-return actuators and 4-way versions for double-acting.

Direct-Mount Solenoid Valves		
Part Number	031-0576-01	031-0580-01
Enclosure	NEMA IV	NEMA VII
Configuration	3 or 4-way	
Pipe Size	1/4" Inlet, 1/8" Exhaust	
Cv	0.7	
Voltage	Standard: 120 VAC 60 Hz (110/50) Optional: 240 VAC 60 Hz, 12 VDC, 24 VDC	
Body Material	Black Anodized Aluminum	
Power Consumption	AC: 6.9 watts or DC: 6.3 watts	
Humidity Resistant	Feature rebreather and are suitable for humid & tropical environment	

**NOTE:** Please consult factory for other solenoid valves or additional options including special voltages, double solenoids, special electrical connections, etc.

### Mechanical Safety Lockout

To comply with the intent of OSHA requirements for locking actuators in position prior to performing maintenance, an actuator can have the mechanical safety lockout option added to it. Design of the stop cam allows for locking the actuator in either the full-open or full-closed position. Actuators equipped with this option have a special lockout screw and a tamperproof cover attached to the housing of the actuator with stainless steel wire. The lockout kits are readily available to permanently lock the actuator in place to prevent unwanted operation.

### 100% Adjustable Travel Stop

To limit the rotation on the stroke beyond the standard VPVL actuator, a stainless steel 100%-adjustable travel

stop option can be added. The stops, located in the end caps, allow the valve position to be set anywhere between full closed and full open. This option limits travel of only the counter-clockwise stroke for standard double-acting and spring-closed units. The 100% Adjustable Stop option is specified in the actuator ordering code.

Actuator	100% Travel Stop Lengths			
	L Min		L Max	
	inch	mm	inch	mm
VPVL051	6.2	158	7.3	186
VPVL100	7.2	184	8.5	216
VPVL200	9.5	242	11.3	286
VPVL250	11.0	280	13.0	330
VPVL300	11.9	303	14.1	359
VPVL350	14.0	356	16.7	424
VPVL400	14.5	368	17.5	444
VPVL450	17.7	449	21.1	537
VPVL500	18.1	461	21.9	555
VPVL550	20.9	531	24.8	631
VPVL600	24.7	628	29.1	739
VPVL650	25.7	653	30.9	785
VPVL700	30.0	762	36.1	918
VPVL800	35.8	910	42.8	1086

Lockout Kits	
VPVL051	LD98
VPVL100	LD99
VPVL200	LD100
VPVL250	LD101
VPVL300	LD102
VPVL350	LD103
VPVL400	LD104
VPVL450	LD105
VPVL500	LD106
VPVL550	LD107
VPVL600	LD108
VPVL650	LD109
VPVL700	LD110
VPVL800	LD111

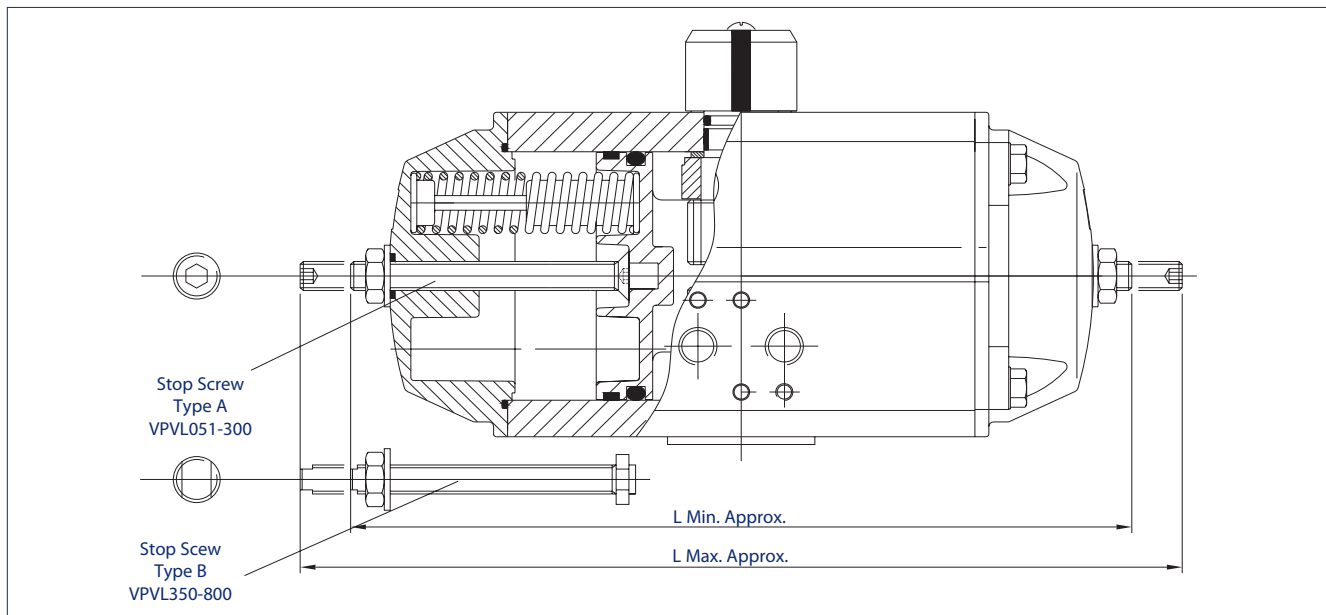
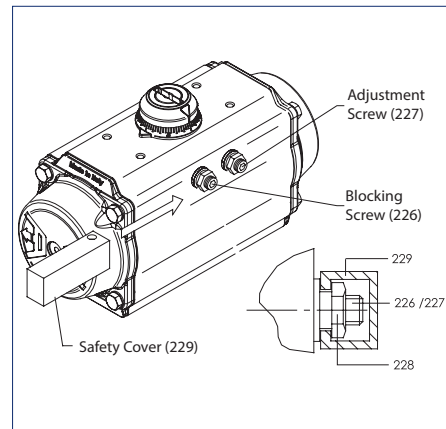

### Declutchable Manual Override

A side-declutchable manual override is available for VPVL actuators. It consists of a manual gear actuator mounted between the actuator and the valve. The device is normally disengaged from the shaft. Upon engagement of the override clutch, overriding the actuator is done with ease, aided by the high-reduction ratio of the manual gear unit.



### DIMENSIONS

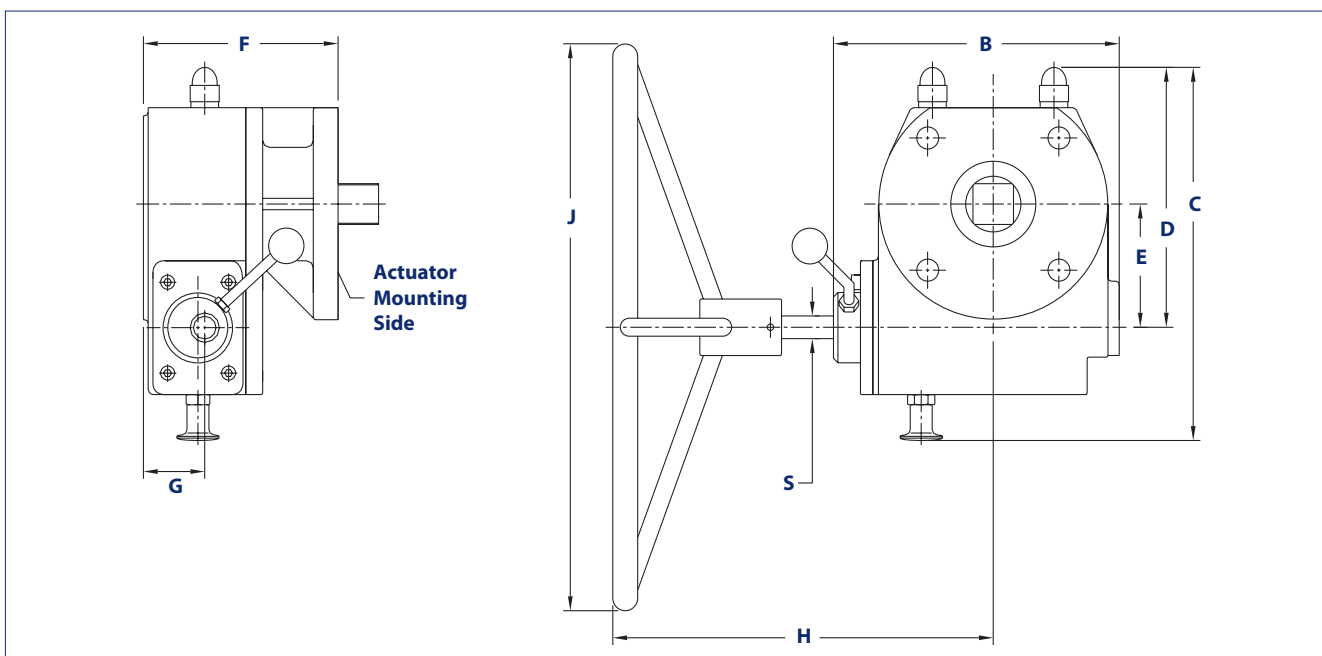

VPVL Actuator Model (DA or SR)	Declutchable Override Kit	Approximate Dimensions - Inches									Approx. Weight lbs.
		B	C	D	E	F	G	H	J	S	
VPVL250 and VPVL300	DO-1	5.75	6.89	5.61	2.36	4.53	1.44	8.94	7.87	0.47	22
VPVL350 and VPVL400	DO-2	7.68	9.49	6.06	2.48	5.63	2.09	10.28	7.87	0.59	40
VPVL450 and VPVL500	DO-3	8.74	11.12	7.46	3.31	6.30	2.48	10.63	11.81	0.79	50
VPVL550 and VPVL600	DO-4	9.84	12.84	9.00	4.23	6.77	2.36	13.31	19.69	0.79	84
VPVL650 and VPVL700*	DO-5	10.87	14.45	10.16	5.00	7.48	2.68	14.41	35.43	0.98	141
VPVL800	DO-6	13.39	16.69	12.32	6.06	8.07	3.07	15.63	39.37	0.98	201

\* The VPVL700 DA unit may be used if the air pressure required to produce the needed output torque is lower than 95 psi.

VPVL Actuator Model (DA or SR)	Declutchable Override Kit	Approximate Dimensions - mm									Approx. Weight kgs.
		B	C	D	E	F	G	H	J	S	
VPVL250 and VPVL300	DO-1	146	175	142	60	115	37	227	200	12	10
VPVL350 and VPVL400	DO-2	195	241	154	63	143	53	261	200	15	18
VPVL450 and VPVL500	DO-3	222	282	190	84	160	63	270	300	20	23
VPVL550 and VPVL600	DO-4	250	326	228	107	172	60	338	500	20	38
VPVL650 and VPVL700*	DO-5	276	367	258	127	190	68	366	900	25	64
VPVL800	DO-6	340	424	313	154	205	78	397	1000	25	91

\* The VPVL700 DA unit may be used if the air pressure required to produce the needed output torque is lower than 6.5 bar.

**DIMENSIONS - VPVL**

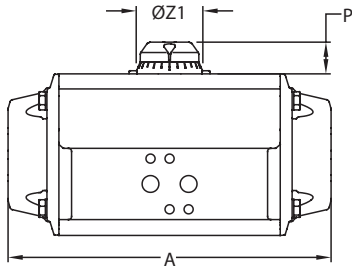

VPVL051 thru VPVL600

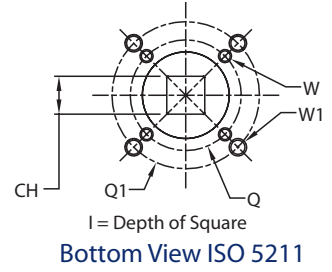
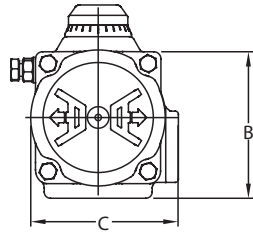

Bottom View ISO 5211

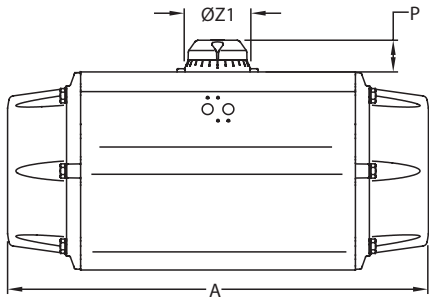

VPVL700

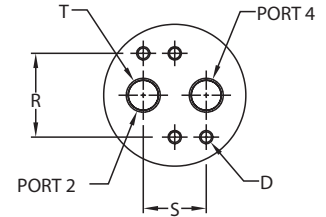
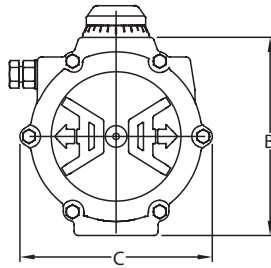

VPVL051 thru VPVL600

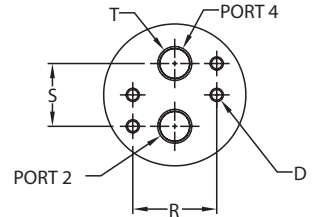

VPVL650 thru VPVL800

4 X 4

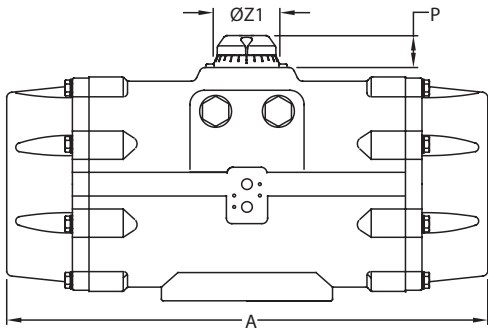

VPVL800

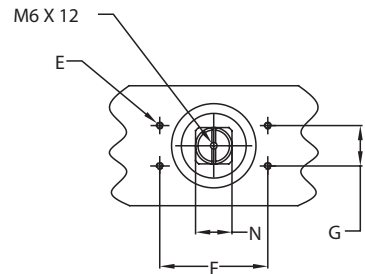
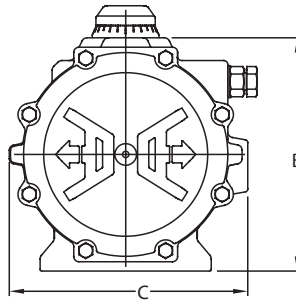

Top View

**DIMENSIONS - VPLSS**

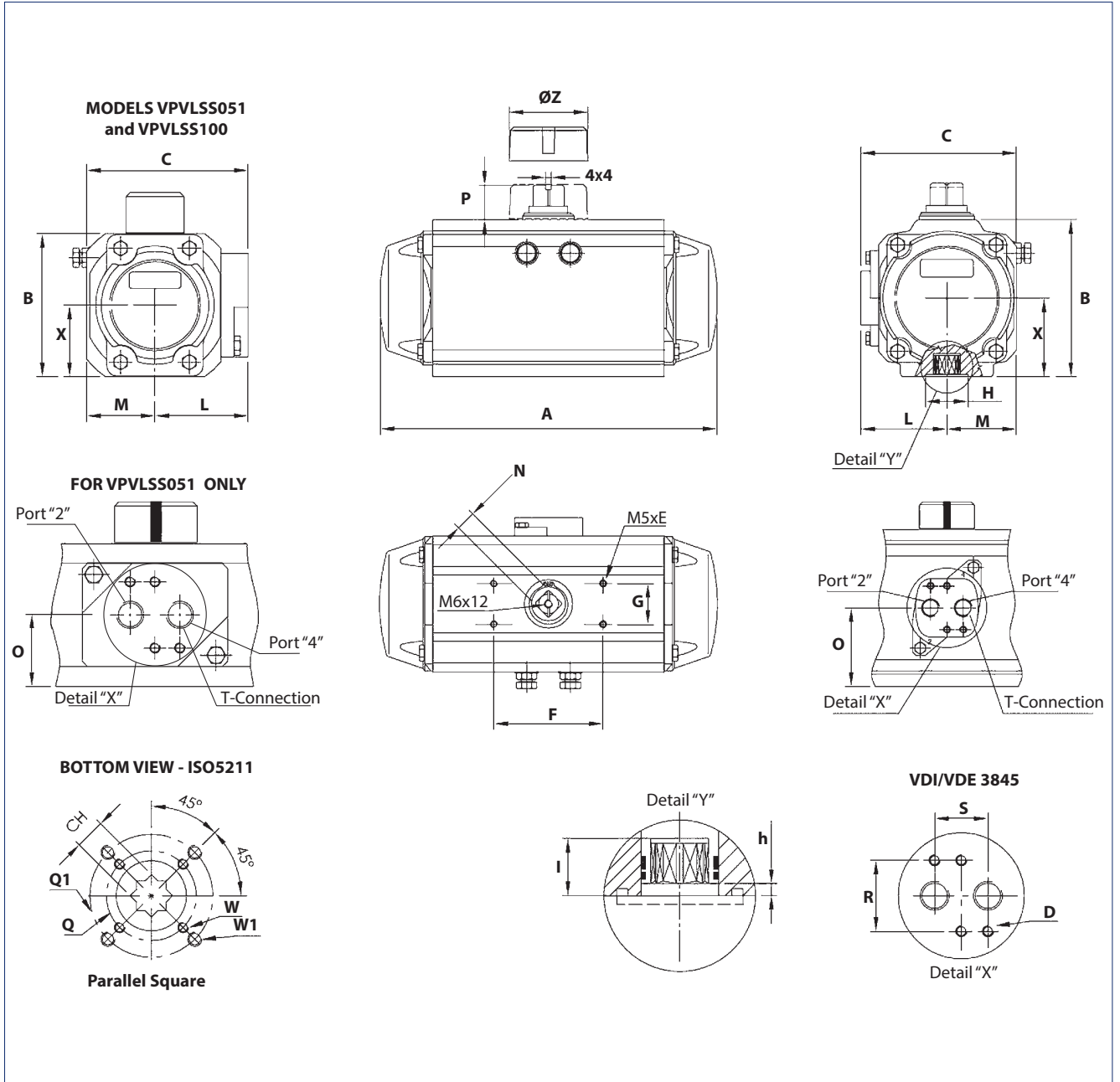

**DIMENSIONS - VPVL**

Size	Dimensions - inches															Weight - pounds						
	A	B	C	D	E	F	G	N	P	R	S	T (NPT)	Z	ISO Flange	Q	Q1	W	W1	CH	I	DA	SR
VPVL051	5.39	2.72	2.83	M5 X 0.31	M5 X 0.31	3.15	1.18	0.43	0.79	1.26	0.94	1/8"	1.65	F03 + F05	1.42	1.97	M5	M6	0.43	0.47	2.2	2.4
VPVL100	6.04	3.35	3.33	M5 X 0.31	M5 X 0.31	3.15	1.18	0.55	0.79	1.26	0.94	1/8"	1.65	F05 + F07	1.97	2.76	M6	M8	0.55	0.63	3.5	3.7
VPVL200	8.01	4.02	3.66	M5 X 0.31	M5 X 0.31	3.15	1.18	0.55	0.79	1.26	0.94	1/8"	1.65	F05 + F07	1.97	2.76	M6	M8	0.55	0.63	6.0	6.8
VPVL250	9.49	4.53	4.06	M5 X 0.31	M5 X 0.31	3.15	1.18	0.75	0.79	1.26	0.94	1/8"	1.65	F05 + F07	1.97	2.76	M6	M8	0.75	0.83	8.2	9.5
VPVL300	10.20	5.00	4.67	M5 X 0.31	M5 X 0.31	3.15	1.18	0.75	0.79	1.26	0.94	1/4"	1.65	F07 + F10	2.76	4.02	M8	M10	0.75	0.83	11.5	13.4
VPVL350	11.97	5.71	5.39	M5 X 0.31	M5 X 0.31	3.15	1.18	0.87	1.18	1.26	0.94	1/4"	2.28	F07 + F10	2.76	4.02	M8	M10	0.87	0.94	17.6	20.5
VPVL400	13.11	6.18	5.79	M5 X 0.31	M5 X 0.31	3.15	1.18	0.87	1.18	1.26	0.94	1/4"	2.28	F07 + F10	2.76	4.02	M8	M10	0.87	0.94	21.6	25.8
VPVL450	15.53	6.97	6.54	M5 X 0.31	M5 X 0.31	3.15	1.18	1.06	1.18	1.26	0.94	1/4"	2.66	F10 + F12	4.02	4.92	M10	M12	1.06	1.14	31.3	38.4
VPVL500	16.63	7.72	7.13	M5 X 0.31	M5 X 0.31	3.15	1.18	1.06	1.18	1.26	0.94	1/4"	2.66	F10 + F12	4.02	4.92	M10	M12	1.06	1.14	39.9	49.2
VPVL550	18.66	8.68	7.87	M5 X 0.31	M5 X 0.31	5.12	1.18	1.42	1.97	1.26	0.94	1/4"	3.15	F14	5.51	5.51	M16	-	1.42	1.50	53.6	72.1
VPVL600	20.79	9.65	8.58	M5 X 0.31	M5 X 0.31	5.12	1.18	1.42	1.97	1.26	0.94	1/4"	3.15	F14	5.51	5.51	M16	-	1.42	1.50	75.2	92.4
VPVL650	23.82	11.75	10.16	M6 X 0.39	M5 X 0.31	5.12	1.18	1.81	1.97	1.77	1.57	3/8"	4.53	F16	6.50	6.50	M20	-	1.81	1.89	116.2	148.4
VPVL700	27.95	12.99	12.56	M6 X 0.39	M5 X 0.31	5.12	1.18	1.81	1.97	1.77	1.57	1/2"	4.53	F16	6.50	6.50	M20	-	1.81	1.89	163.1	205.0
VPVL800	34.49	16.14	16.46	M6 X 0.39	M5 X 0.31	5.12	1.18	2.17	1.97	1.77	1.57	1/2"	4.53	F16 + F25	6.50	10.00	M20	M16	2.17	2.24	280.0	372.6

Size	Dimensions - millimeters															Weight - kilograms						
	A	B	C	D	E	F	G	N	P	R	S	T (NPT)	Z	ISO Flange	Q	Q1	W	W1	CH	I	DA	SR
VPVL051	137.0	69	72	M5 X 8	M5 X 8	80	30	11	20	32	24	1/8"	42	F03 + F05	36	50	M5	M6	11	12	1.0	1.1
VPVL100	153.5	85	85	M5 X 8	M5 X 8	80	30	14	20	32	24	1/8"	42	F05 + F07	50	70	M6	M8	14	16	1.6	1.7
VPVL200	203.5	102	93	M5 X 8	M5 X 8	80	30	14	20	32	24	1/8"	42	F05 + F07	50	70	M6	M8	14	16	2.7	3.1
VPVL250	241.0	115	103	M5 X 8	M5 X 8	80	30	19	20	32	24	1/8"	42	F05 + F07	50	70	M6	M8	19	21	3.7	4.3
VPVL300	259.0	127	119	M5 X 8	M5 X 8	80	30	19	20	32	24	1/4"	42	F07 + F10	70	102	M8	M10	19	21	5.2	6.1
VPVL350	304.0	145	137	M5 X 8	M5 X 8	80	30	22	30	32	24	1/4"	58	F07 + F10	70	102	M8	M10	22	24	8.0	9.3
VPVL400	333.0	157	147	M5 X 8	M5 X 8	80	30	22	30	32	24	1/4"	58	F07 + F10	70	102	M8	M10	22	24	9.8	11.7
VPVL450	394.5	177	166	M5 X 8	M5 X 8	80	30	27	30	32	24	1/4"	68	F10 + F12	102	125	M10	M12	27	29	14.2	17.4
VPVL500	422.5	196	181	M5 X 8	M5 X 8	80	30	27	30	32	24	1/4"	68	F10 + F12	102	125	M10	M12	27	29	18.1	22.3
VPVL550	474.0	221	200	M5 X 8	M5 X 8	130	30	36	50	32	24	1/4"	80	F14	140	140	M16	-	36	38	24.3	32.7
VPVL600	528.0	245	218	M5 X 8	M5 X 8	130	30	36	50	32	24	1/4"	80	F14	140	140	M16	-	36	38	34.1	41.9
VPVL650	605.0	299	258	M6 X 10	M5 X 8	130	30	46	50	45	40	3/8"	115	F16	165	165	M20	-	46	48	52.7	67.3
VPVL700	710.0	330	319	M6 X 10	M5 X 8	130	30	46	50	45	40	1/2"	115	F16	165	165	M20	-	46	48	74.0	93.0
VPVL800	876.0	410	418	M6 X 10	M5 X 8	130	30	55	50	45	40	1/2"	115	F16 + F25	165	254	M20	M16	55	57	127.0	169.0

**DIMENSIONS - VPVLSS**

Size	Dimensions - inches / lb.																				Weight							
	A	B	C	D	E	F	G	H	I min.	L	M	N	O	P	Q	Q1	R	S	TNPT	W	W1	X	ISO Flange	CH	h min.	Z	DA	SR
	051	5.55	2.72	2.95	M5x8	0.16	3.15	1.18	0.98	0.47	1.65	1.30	0.43	1.38	0.79	1.42	-	1.26	0.94	1/8"	M5	-	1.36	F03	0.43	0.02	1.57	5.9
100	6.26	3.35	3.39	M5x8	0.31	3.15	1.18	1.38	0.63	1.93	1.46	0.55	1.69	0.79	1.97	-	1.26	0.94	1/4"	M6	-	1.67	F05	0.55	0.02	1.57	8.4	8.8
200	8.31	4.02	3.90	M5x8	0.31	3.15	1.18	1.38	0.63	2.20	1.73	0.55	2.01	0.79	1.97	2.76	1.26	0.94	1/4"	M6	M8	2.01	F05 + F07	0.55	0.06	1.57	13.6	14.5
250	9.76	4.53	4.49	M5x8	0.31	3.15	1.18	1.57	0.83	2.48	2.01	0.75	2.28	0.79	1.97	2.76	1.26	0.94	1/4"	M6	M8	2.26	F05 + F07	0.75	0.06	1.57	20	21.4
300	10.55	5.00	5.04	M5x8	0.31	3.15	1.18	2.17	0.83	2.80	2.28	0.75	2.52	0.79	2.76	4.02	1.26	0.94	1/4"	M8	M10	2.50	F07 + F10	0.75	0.06	1.57	26.2	28.7

Size	Dimensions - inches / lb.																				Weight							
	A	B	C	D	E	F	G	H	I min.	L	M	N	O	P	Q	Q1	R	S	TNPT	W	W1	X	ISO Flange	CH	h min.	Z	DA	SR
	051	141	69	75	M5x8	4	80	30	25	12	42	33	11	35	20	36	-	32	24	1/8"	M5	-	34.5	F03	11	0.5	40	2.7
100	159	85	86	M5x8	8	80	30	35	16	49	37	14	43	20	50	-	32	24	1/4"	M6	-	42.5	F05	14	0.5	40	3.8	4.0
200	211	102	99	M5x8	8	80	30	35	16	56	44	14	51	20	50	70	32	24	1/4"	M6	M8	51	F05 + F07	14	1.5	40	6.2	6.6
250	248	115	114	M5x8	8	80	30	40	21	63	51	19	58	20	50	70	32	24	1/4"	M6	M8	57.5	F05 + F07	19	1.5	40	9.1	9.7
300	268	127	128	M5x8	8	80	30	55	21	71	58	19	64	20	70	102	32	24	1/4"	M8	M10	63.5	F07 + F10	19	1.5	40	11.9	13.0

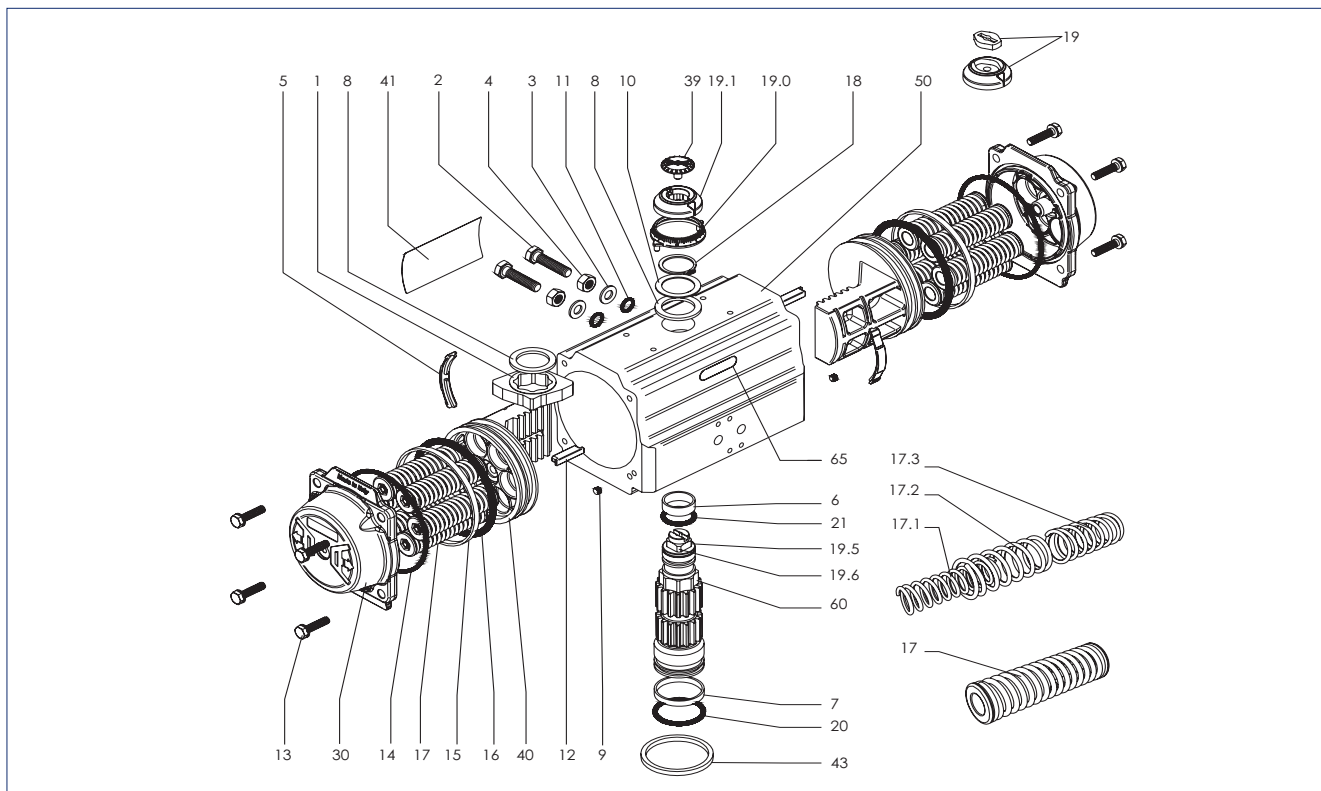

### BILL OF MATERIALS AND PARTS LIST - VPVL

No.	Unit Qty	Part Description	Material	Specifications	Corrosion Protection
1	1	Octi-Cam (Stop Arrangement)	Stainless Steel	EN 10088-3/ISO 10831	
2	2	Stop Cap Screw	Stainless Steel	ASTM A193	
3	2	Washer (Stop Cap Screw)	Stainless Steel	ISO 3506	
4	2	Nut (Stop Cap Screw)	Stainless Steel	ISO 3506	
5*	2	Bearing (Piston Back)	Polyphthalamide	Amodel ET1001HS	
6*	1	Bearing (Pinion Top)	Polyetherimide	Stanyl TW300	
7*	1	Bearing (Pinion Bottom)	Polyetherimide	Stanyl TW300	
8*	2	Thrust Bearing (Pinion)	Polyphthalamide	Amodel ET1001HS	
9*	2	Plug (Transfer Port)	Nitrile Rubber	NBR 70Shore A	
10	1	Thrust Washer (Pinion)	Stainless Steel	EN 10088-3	
11*	2	O-ring (Stop Cap Screw Seal)	Nitrile Rubber	NBR 70Shore A	
12	2	Piston Guide	Polyphthalamide GF	Amodel AS1145	
13	8/12/16	Cap Screw (End Cap)	Stainless Steel	ISO 3506	
14*	2	O-ring (End Cap)	Nitrile Rubber	NBR 70Shore A	
15*	2	Bearing (Piston Head)	Polyphthalamide	Amodel ET1001HS	
16*	2	O-ring (Piston)	Nitrile Rubber	NBR 70Shore A	
17	min. 4/ max.12	Spring (Cartridge)	Alloy Steel	DIN 17223 Part2	Epoxy Coated
17.1					
17.2	max. 2	Spring	Alloy Steel	DIN 17223 Part2	Epoxy Coated
17.3					
18	1	Spring Clip (Pinion)	Carbon Steel	DIN 17222	ENP
19	1	Position Indicator <sup>3</sup>	High-grade Polymer/Stainless Steel		
19.0	1	Graduated Ring	High-grade Polymer		
19.1	1	Position Indicator	High-grade Polymer		
19.5	1	Top Adapter	Extruded Aluminum		
19.6	1	Hex Socket Screw	Stainless Steel		
20*	1	O-ring (Pinion Bottom)	Nitrile Rubber	NBR 70Shore A	
21*	1	O-ring (Pinion Top)	Nitrile Rubber	NBR 70Shore A	
30	1	End Cap	Aluminum	UNI 5075	Polyester-Coated
39	1	Cap Screw (Indicator)	Stainless Steel	ISO 3506	
40	2	Pistons	Aluminum	UNI 5075	Anodized
41	1	Actuator Identification Label	Polyester Aluminum		
50	1	Body	Aluminum	ASTM B221	Anodized PTFE-Coated
60	1	Drive Shaft	Carbon Steel Plated	ASTM A105	ENP
65	1	Plastic Label	High-grade Polymer		

\* Suggested spare parts for maintenance

- Notes:
- (1) AISI 420 for models VPVL-051 through 300; GS400-15 for models VPVL-350 through 800
  - (2) Qty 8 pieces for models VPVL-051 through 650; Qty 12 pieces for model VPVL-700 through 750; Qty 16 pieces for model VPVL800
  - (3) For models VPVL051 through 100

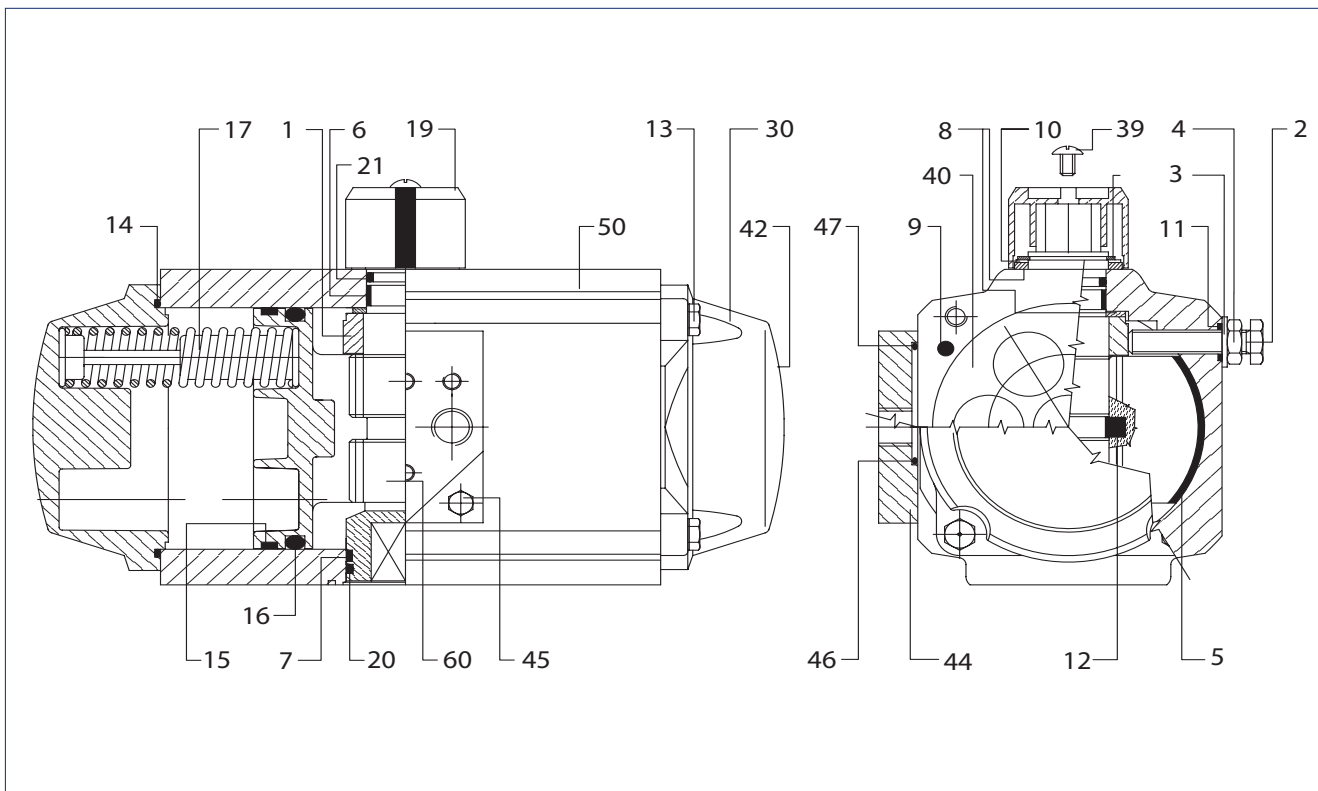

**BILL OF MATERIALS AND PARTS LIST - VPVLS**

No.	Unit Qty	Part Description	Material	Specifications
1	1	Octi-Cam (Stop Arrangement)	Stainless Steel	EN 10088-3
2	2	Stop Cap Screw	Stainless Steel	ISO 3506
3	2	Washer	Stainless Steel	ISO 3506
4	2	Nut (Stop Screw)	Stainless Steel	ISO 3506
5*	2	Bearing (Piston Back)	Polyphthalamide	Stanyl TW300
6*	1	Bearing (Pinion Top)	Polyetherimide	Stanyl TW300
7*	1	Bearing (Pinion Bottom)	Polyetherimide	Stanyl TW300
8*	2	Thrust Bearing (Pinion)	Polyphthalamide	Stanyl TW300
9*	2	Plug	Nitrile Rubber	NBR 70Shore A
10	1	Thrust Washer (Pinion)	Stainless Steel	EN 10088-3
11*	2	O-ring (Stop Screw)	Nitrile Rubber	NBR 70Shore A
12	2	Piston Guide	Polyphthalamide GF	Amodel AS1145
13	8	Cap Screw (End Cap)	Stainless Steel	ISO 3506
14*	2	O-ring (End Cap)	Nitrile Rubber	NBR 70Shore A
15*	2	Bearing (Piston Head)	Polyphthalamide	
16*	2	O-ring (Piston)	Nitrile Rubber	NBR 70Shore A
17	min. 9/ max.12	Spring (Cartridge)	Alloy Steel	DIN 17223 Part2
18	1	Spring Clip (Pinion)	X35CrMo17	
19	1	Position Indicator	Polypropylene GF	Halplen EP30
20*	1	O-ring (Pinion Bottom)	Nitrile Rubber	NBR 70Shore A
21*	1	O-ring (Pinion Top)	Nitrile Rubber	NBR 70Shore A
30	2	End Caps	Stainless Steel	EN 10088-3 / ASTM A351
39	1	Cap Screw (Indicator)	Stainless Steel	ISO 3506
40	2	Pistons	Aluminum	UNI 5075
44	1	NAMUR Connecting Plate	Stainless Steel	EN 10088-3
45	2	Cap Screw (Connection Plate)	Stainless Steel	ISO 3506
46	1	O-ring (Port 2)	Nitrile Rubber	NBR 70Shore A
47	1	O-ring (Port 4)	Nitrile Rubber	NBR 70Shore A
50	1	Body	Stainless Steel	EN 10088-3 / ASTM A182
60	1	Drive Shaft	Stainless Steel	EN 10088-3 / ASTM A582

\* Suggested spare parts for maintenance

**WARNING:** As the use of the actuator is application specific, a number of factors should be taken into account when selecting a valve for a given application. Therefore, some of the situations in which the valves are used are outside the scope of this manual. If you have any questions concerning the use, application or compatibility of the valve with the intended service, contact Neles for more information.

### HOW TO ORDER - VPVL

To specify a complete Valv-Powr Value-Line™ actuator, simply make a selection from the code boxes below.

**EXAMPLE:** VPVL 400 SR4/5 B AS D, shown below, is a 59 FT•LBS 60-psi (84 N•m @ 4.2 bar) spring-return actuator with spring-to-close rotation, hard-anodized PTFE-coated body, polyester-coated end caps, standard temperature rating, and 100% adjustable travel stops.

1	2	3	4	5	6	7
VPVL	400	SR4/5	B	AS	D	—

**NOTE:** for multiple options, specify them in order as listed in item 5, for example: VPVL400 SR4/5 B HT AS Model D.

1	Product Group
VPVL	Valv-Powr Double-Opposed Piston Actuator

2	Size
051,	Select from torque table
100, 200,	
250, 300,	
350, 400,	
450, 500,	
550, 600,	
650, 700,	
800	

3	Series+
DA	Double acting, pneumatic
SR4/5	Spring-Return 60-psi (4.1 bar) Spring-to-Close (CW Rotation)
SR6	Spring-Return 80-psi (5.5 bar) Spring-to-Close (CW Rotation)

+ Other spring rates on application

4	Exterior Protection*
B	Hard-Anodized PTFE-Coated Body & Polyester-Coated End Caps

\* Consult factory for other protection options.

5	Options
-	Standard Temperature Rating: -40°F to +176°F (-40°C to +80°C)
HT†	High-Temperature Rating: +5°F to +302°F (-15°C to +150°C)
LX†	Low-Temperature Rating: -60°F to +176°F (-51°C to +80°C)
FO	Spring-to-Open (CCW Rotation)
AS	100% Travel Stop
LD	Mechanical Safety Lockout

† HT and LX options decrease cycle life.

6	Model
D	Model D

7	Modifier Code
-	Standard

**WARNING:** As the use of the actuator is application specific, a number of factors should be taken into account when selecting a valve for a given application. Therefore, some of the situations in which the valves are used are outside the scope of this manual. If you have any questions concerning the use, application or compatibility of the valve with the intended service, contact Neles for more information.

### HOW TO ORDER - VPVLSS

To specify a complete Valv-Powr Value-Line actuator, simply make a selection from the code boxes below.

**EXAMPLE:** VPVLSS200 SR4/5, shown below, is a 13.1 FT•LBS @ 60-psi (17 N•m @ 4.2 bar) spring-return actuator with spring-to-close rotation.

1	2	3	4	5	6	7
VPVLSS		200	SR4/5	—	D	—

1	Product Group
VPVLSS	Valv-Powr Double-Opposed Piston Actuator

2	Exterior Option
-	Standard
P	Polished Surfaces

3	Size
051	Select from torque table
100	
200	
250	
300	

4	Series+
DA	Double acting, pneumatic
SR4/5	Spring-Return 60-psi (4.1 bar) Spring-to-Close (CW Rotation)
SR6	Spring-Return 80-psi (5.5 bar) Spring-to-Close (CW Rotation)

+ other spring rates on application

5	Options
-	Standard Temperature Rating: -40°F +176°F (-40°C to +80°C)
HT†	High Temperature Rating: +5°F to +302°F (-15°C to +150°C)
LX†	Low Temperature Rating: -60°F to +176°F (-51°C to +80°C)
FO	Spring-to-Open (CCW Rotation)
AS	100% Travel Stops

† HT and LX options decrease cycle life.

6	Model
D	Model D

7	Modifier Code
-	Standard





# Neles

Vanha Porvoontie 229, 01380 Vantaa, Finland.  
Tel. +358 10 417 5000.

**neles.com**

A111-5EN - 11/2020

Subject to change without prior notice. Neles, Jamesbury and Easyflow by Neles, and certain other trademarks, are either registered trademarks or trademarks of Neles Corporation or its subsidiaries or affiliates in the United States and/or in other countries. For more information [www.neles.com/trademarks](http://www.neles.com/trademarks)

Reinventing  
reliability