

NELES

Flanged Ball Valves

Series 7000, 9000, 9150, 9180 Model C,
Class 150, Full Bore 2", 3", 4", 6", & 8"
(DN50, 80, 100, 150 & 200)

Series 9300, 9380 Model C, Class 300,
Full Bore 2", 3", 4", 6" & 8" (DN50, 80, 150, 200 & 250)

Series 7150, 7180 Model C, Class 150,
Standard Bore 8" & 10" (DN200 & 250),

Standard and Emission-Pak® Non-Trunnion Valves

Series 7300, 7380, 730S, 738S Model C, Class 300,
Standard bore, 8" & 10" (DN200 & 250)

Installation, maintenance and
operating instructions

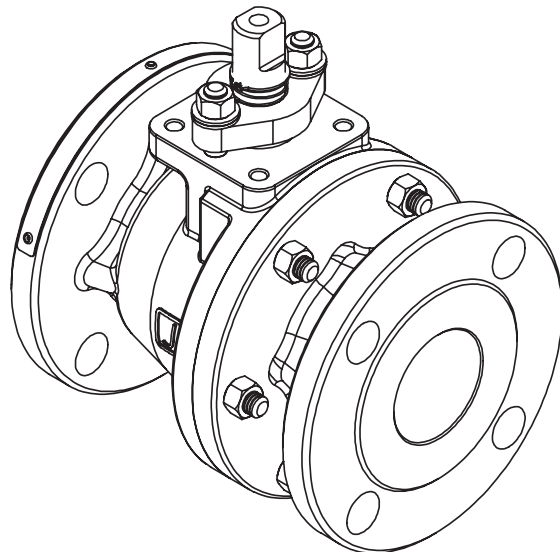

TABLE OF CONTENTS

1	GENERAL	3
1.1	Scope of the Manual.....	3
1.2	Valve Markings	3
1.3	Safety Precautions	3
3	INSTALLATION	4
3.1	General.....	4
3.2	Installing in the pipeline	4
3.3	Valve Insulation	4
3.4	Actuator.....	4
3.5	Commissioning.....	5
4	MAINTENANCE	5
4.1	General.....	5
4.2	Actuated Valve	5
4.3	Manual Valve – with Handle	5
4.4	Disassembly – bare stem valves	5
4.5	Disassembly - <i>Emission-Pak</i> valves.....	6
4.6	Checking Parts	7
4.7	Assembly – Bare Stem Valves	7
4.8	Assembly - <i>Emission-Pak</i> valve	9
4.9	Testing the Valve	10
5	HANDLE MOUNTING	10
6	STEM EXTENSION MOUNTING	11
7	ACTUATOR MOUNTING	11
7.1	General.....	11
7.2	Valve Preparation.....	12
7.3	Bracket Preparation.....	12
7.4	Bracket Attachment to Valve.....	12
7.5	Actuator versus Valve Position	13
7.6	Coupling to Actuator	13
7.7	Bracket Attachment to Actuator.....	13
7.8	Open/Close Position Adjustment.....	13
8	SERVICE/SPARE PART	14
9	MODEL CODES	17
11	REPAIR KITS	18

READ THESE INSTRUCTIONS FIRST!

These instructions provide information about safe handling and operation of the valve.

If you require additional assistance, please contact the manufacturer or manufacturer's representative.

SAVE THESE INSTRUCTIONS!

Addresses and phone numbers are printed on the back cover.

1 GENERAL

1.1 Scope of the Manual

This instruction manual contains important information regarding the installation, operation and maintenance of the Jamesbury® 2", 3", 4", 6" & 8" (DN50, 80, 100, 150 & 200) ASME Class 150; and the 2", 3", 4", 6" & 8" (DN50, 80, 100, 150 & 200) ASME Class 300, Full Bore, Non-trunnion Series 9000 Model C and 8" & 10" (DN200 & 250) ASME Class 150, and the 8" & 10" (DN200 & 250) ASME Class 300, Standard Bore, Non-trunnion Series 7000 Model C standard and *Emission-Pak* Flanged Ball Valves. Please read these instructions carefully and save them for future reference.

WARNING:

AS THE USE OF THE VALVE IS APPLICATION SPECIFIC, A NUMBER OF FACTORS SHOULD BE TAKEN INTO ACCOUNT WHEN SELECTING A VALVE FOR A GIVEN APPLICATION. THEREFORE, SOME OF THE SITUATIONS IN WHICH THE VALVES ARE USED ARE OUTSIDE THE SCOPE OF THIS MANUAL.

IF YOU HAVE ANY QUESTIONS CONCERNING THE USE, APPLICATION OR COMPATIBILITY OF THE VALVE WITH THE INTENDED SERVICE, CONTACT NELES FOR MORE INFORMATION.

WARNING:

JAMESBURY EMISSION-PAK BALL VALVES WITH THE "LEAK-OFF" OPTION ARE SHIPPED FROM THE FACTORY WITH A PLASTIC PIPE PLUG INSERTED INTO THE "LEAK-OFF" PORT. THIS PLASTIC PIPE PLUG'S ONLY PURPOSE IS TO PREVENT CONTAMINATION FROM ENTERING THE PORT. THE PLASTIC PIPE PLUG WILL NOT RETAIN ANY VALVE PRESSURE AND MUST BE REMOVED PRIOR TO PRESSURIZING THE VALVE. FAILURE TO REMOVE THE PLASTIC PIPE PLUG AND REPLACE IT WITH A SUITABLE PRESSURE RETAINING CONNECTION MAY RESULT IN DAMAGE OR PERSONAL INJURY!

1.2 Valve Markings

The valve has an identification plate attached to the pipeline flange (see Figure 1).

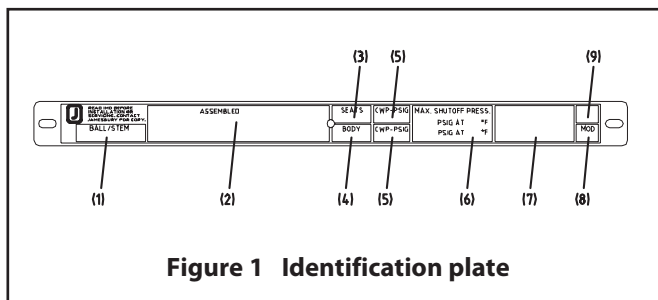

Figure 1 Identification plate

Identification markings:

1	Ball/Stem material
2	Valve catalog code
3	Seat Material
4	Body Material
5	Maximum operating pressure
6	Maximum/minimum shut-off pressure/temperature
7	Approvals/Special Service marking
8	Model
9	Assembly date

1.3 Safety Precautions

WARNING:

DO NOT EXCEED THE VALVE PERFORMANCE LIMITATIONS!

EXCEEDING THE PRESSURE OR TEMPERATURE LIMITATIONS MARKED ON THE VALVE IDENTIFICATION PLATE MAY CAUSE DAMAGE AND LEAD TO UNCONTROLLED PRESSURE RELEASE. DAMAGE OR PERSONAL INJURY MAY RESULT.

WARNING:

SEAT AND BODY RATINGS!

THE PRACTICAL AND SAFE USE OF THIS PRODUCT IS DETERMINED BY BOTH THE SEAT AND BODY RATINGS. READ THE IDENTIFICATION PLATE AND CHECK BOTH RATINGS. THIS PRODUCT IS AVAILABLE WITH A VARIETY OF SEAT MATERIALS. SOME OF THE SEAT MATERIALS HAVE PRESSURE RATINGS THAT ARE LESS THAN THE BODY RATINGS. ALL OF THE BODY AND SEAT RATINGS ARE DEPENDENT ON VALVE TYPE AND SIZE, SEAT MATERIAL, AND TEMPERATURE. DO NOT EXCEED THESE RATINGS!

WARNING:

BEWARE OF BALL MOVEMENT!

KEEP HANDS, OTHER PARTS OF THE BODY, TOOLS AND OTHER OBJECTS OUT OF THE OPEN FLOW PORT. LEAVE NO FOREIGN OBJECTS INSIDE THE PIPELINE. WHEN THE VALVE IS ACTUATED, THE BALL FUNCTIONS AS A CUTTING DEVICE. DISCONNECT ANY PNEUMATIC SUPPLY LINES, ANY ELECTRICAL POWER SOURCES AND MAKE SURE SPRINGS IN SPRING-RETURN ACTUATORS ARE IN THE FULL EXTENDED/RELAXED STATE BEFORE PERFORMING ANY VALVE MAINTENANCE. FAILURE TO DO THIS MAY RESULT IN DAMAGE OR PERSONAL INJURY!

WARNING:

WHEN HANDLING THE VALVE OR VALVE/ACTUATOR ASSEMBLY, TAKE ITS WEIGHT INTO ACCOUNT!

NEVER LIFT THE VALVE OR VALVE/ACTUATOR ASSEMBLY BY THE ACTUATOR, POSITIONER, LIMIT SWITCH OR THEIR PIPING. PLACE LIFTING DEVICES SECURELY AROUND THE VALVE BODY. FAILURE TO FOLLOW THESE INSTRUCTIONS MAY RESULT IN DAMAGE OR PERSONAL INJURY FROM FALLING PARTS (SEE FIGURE 2).

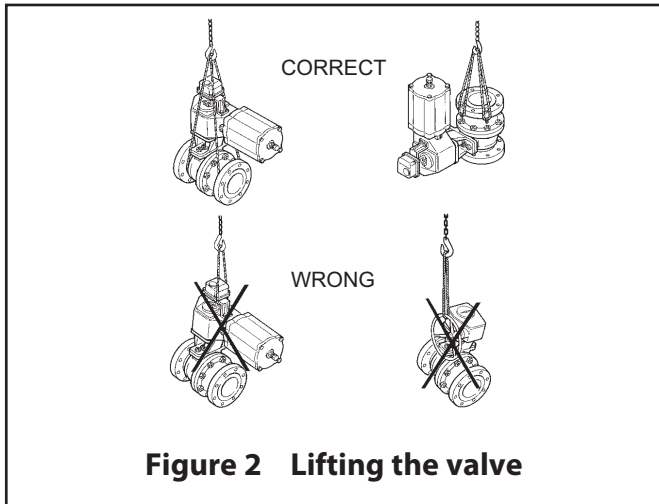

Figure 2 Lifting the valve

2 TRANSPORTATION AND STORAGE

Check the valve and the accompanying devices for any damage that may have occurred during transport.

Store the valve carefully. Storage indoors in a dry place is recommended.

Do not remove the flow port protectors until installing the valve.

Move the valve to its intended location just before installation.

The valve is usually delivered in the closed position. If the valve(s) are to be stored for a long duration, follow the recommendations of IMO-S1.

3 INSTALLATION

3.1 General

Remove the flow port protectors and check that the valve is clean inside. Clean valve if necessary. Place the valve in the open position.

Flush the pipeline carefully before installing the valve. Foreign objects, such as sand or pieces of welding electrodes, will damage the ball and seats.

3.2 Installing in the pipeline

WARNING:

THE VALVE SHOULD BE TIGHTENED BETWEEN FLANGES USING APPROPRIATE GASKETS AND FASTENERS COMPATIBLE WITH THE APPLICATION, AND IN COMPLIANCE WITH APPLICABLE PIPING CODES AND STANDARDS. CENTER THE FLANGE GASKETS CAREFULLY WHEN FITTING THE VALVE BETWEEN FLANGES. DO NOT ATTEMPT TO CORRECT PIPELINE MISALIGNMENT BY MEANS OF FLANGE BOLTING!

The valve may be installed in any position and offers tightness in both directions. It is recommended, however, that the valve be installed with the insert facing upstream. It is not recommended to install the valve with the stem on the underneath side because dirt in the pipeline may then enter the body cavity and potentially damage the stem packing (see **Figure 3**).

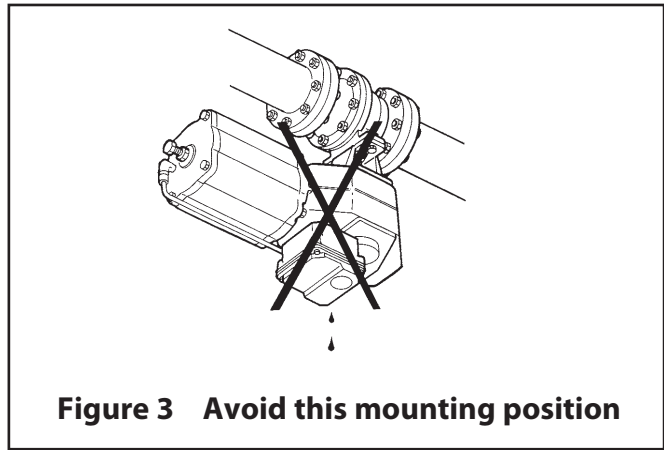

Figure 3 Avoid this mounting position

Refer to the Section 4, **MAINTENANCE** for stem seal adjustment. If there is weepage past the stem seals upon installation, it means the valve may have been subject to wide temperature variations in shipment. Leak-tight performance will be restored by a simple stem seal adjustment described in the **MAINTENANCE** section.

3.3 Valve Insulation

*Jamesbury 7000 and 9000 series Flanged Ball Valves do NOT require insulation. If desired, the valve may be insulated; however, the insulation must not continue above the upper level of the valve (see **Figure 4**).*

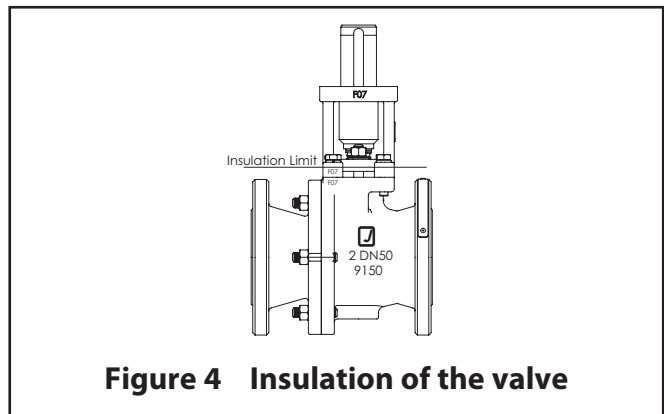

Figure 4 Insulation of the valve

3.4 Actuator

WARNING:

WHEN INSTALLING THE ACTUATOR ON THE VALVE, MAKE SURE THAT THE VALVE ASSEMBLY FUNCTIONS PROPERLY. INFORMATION ON ACTUATOR INSTALLATION IS GIVEN IN **SECTION 7** OR IN THE SEPARATE ACTUATOR INSTRUCTIONS.

The actuator should be installed in a manner that allows plenty of room for its removal.

The upright position is recommended for the actuator.

The actuator must not touch the pipeline, because pipeline vibration may interfere with its operation.

In certain cases it may be considered advantageous to provide additional support to the actuator. These cases will normally be associated with large actuators, extended stems, or where severe vibration is present. Please contact Neles for advice.

3.5 Commissioning

Ensure that there is no dirt or foreign objects left inside the valve or pipeline. Flush the pipeline carefully. Make sure that the valve is fully open when flushing.

Ensure that all nuts, fittings, and cables are properly fastened.

If so equipped, check that the actuator positioner and/or switch are correctly adjusted. Actuator adjustment is explained in **Section 7.8**. To adjust any accompanying device(s) refer to the separate control equipment instruction manuals.

4 MAINTENANCE

4.1 General

Although Neles *Jamesbury* valves are designed to work under severe conditions, proper preventative maintenance can significantly help to prevent unplanned downtime and in real terms reduce the total cost of ownership. Neles recommends inspecting valves at least every five (5) years. The inspection and maintenance frequency depends on the actual application and process condition. Routine maintenance consists of tightening the stud nuts (item 30 in **Figure 18**) periodically to compensate for stem seal wear.

Always loosen and tighten fasteners with the appropriate wrench to avoid damaging the valve, handle, linkage, actuator, fittings or flats.

Overhaul maintenance consists of replacing seats and seals. A standard repair kit consisting of these parts may be obtained through your authorized Neles Distributor.

NOTE: Repair kits include thrust bearings (13), secondary stem seal (7), seats (5), body seal (6) and stem seals (8). Refer to the Repair Kit chart (see **Table 10A or 10B**).

WARNING:

FOR YOUR SAFETY IT IS IMPORTANT THE FOLLOWING PRECAUTIONS BE TAKEN PRIOR TO REMOVAL OF THE VALVE FROM THE PIPELINE OR BEFORE ANY DISASSEMBLY:

1. WEAR ANY PROTECTIVE CLOTHING OR EQUIPMENT NORMALLY REQUIRED WHEN WORKING WITH THE FLUID INVOLVED.
2. DEPRESSURIZE THE PIPELINE AND CYCLE THE VALVE AS FOLLOWS:
 - A. PLACE THE VALVE IN THE OPEN POSITION AND DRAIN THE PIPELINE.
 - B. CYCLE THE VALVE TO RELIEVE RESIDUAL PRESSURE IN THE BODY CAVITY BEFORE REMOVAL FROM THE PIPELINE.
 - C. AFTER REMOVAL AND BEFORE ANY DISASSEMBLY, CYCLE THE VALVE AGAIN SEVERAL TIMES.

4.2 Actuated Valve

It is generally most convenient to detach the actuator and its auxiliary devices before removing the valve from the pipeline. If the valve package is small or if it is difficult to access, it may be more practical to remove the entire assembly.

NOTE: To ensure proper reassembly, observe the position of the actuator and positioner/limit switch with respect to the valve before detaching the actuator.

WARNING:

ALWAYS DISCONNECT THE ACTUATOR FROM ITS POWER SOURCE, PNEUMATIC, HYDRAULIC OR ELECTRICAL, BEFORE ATTEMPTING TO REMOVE IT FROM THE VALVE!

WARNING:

DO NOT REMOVE A SPRING-RETURN ACTUATOR UNLESS A STOP-SCREW IS CARRYING THE SPRING FORCE!

1. Detach the air supply, electrical supply, hydraulic supply and control signal cables or pipes from their connectors.
2. Remove the actuator mounting bracket screws (6) and lockwashers (7) (see **Figure 14 or 16**).
3. Lift the actuator straight up in line with the valve stem until the coupling (1) between actuator drive and valve stem is completely disengaged.
4. Place actuator in a safe location to avoid damage or personal injury.

4.3 Manual Valve – with Handle

1. Remove the handle screw (6) and washer (5). Lift the handle (1) straight up in line with the valve stem until it is completely disengaged (see **Figure 11**).
2. Remove the four bracket screws (3) and lock washers (4).
3. Lift the handle bracket (2) straight up in line with the valve stem until it is completely disengaged.
4. Place all disassembled handle parts in small basket or bag to prevent damage or loss.

4.4 Disassembly – bare stem valves

NOTE: If complete disassembly becomes necessary; it is recommended to replace all seats and seals. Refer to the Repair Kit chart (see **Table 10A**).

NOTE: Always use original OEM parts to make sure that the valve functions properly.

1. Follow the steps in all the **WARNING** sections above before performing any work on the valve.
2. Open and close the valve and leave in the closed position.
3. Place the valve in the vertical position with the body cap end up.

4. Mark the body joint flanges to assure correct body (1) and body cap (2) orientation during assembly. Remove body stud nuts (33) and remove body cap (2). **BE CAREFUL NOT TO SCRATCH THE BALL.**
5. Remove and discard the body seal (6) and the seat (5) from the body cap.
6. Rotate the stem (4) so that the ball is in the closed position for removal. If the ball (3) does not swing free from the body, with the ball in the fully closed position, use a piece of wood or some other soft material to gently tap the ball (from the end opposite the body cap). This should loosen the ball so that it can be pivoted free of the stem (4). The bottom grounding spring (71), located in bottom of the stem (4), may fall out at this time. If the spring does not fall out with the stem, remove it from the stem to prevent it from being lost.
7. Carefully remove and discard the bottom seat (5) out of the body, **BEING CAREFUL NOT TO SCRATCH THE BODY SEALING SURFACE BEHIND THE SEAT.**
8. Remove retaining ring (72) and top grounding spring (70) from stem (4).
9. Remove the stud nuts (30), disc springs (31), and compression plate (20). Pay careful attention to the orientation of the disc springs (31) and make sure they are in the same orientation during re-assembly.
10. Press the stem (4) from the top into the valve body and remove it through the body cap end of the body.
11. Remove and discard the thrust bearings (13), and secondary stem seal (7), **BEING CAREFUL NOT TO SCRATCH ANY SEALING SURFACES IN THE BODY.**
12. Remove and discard the stem seals (8), **BEING CAREFUL NOT TO SCRATCH ANY SEALING SURFACE INSIDE THE STEM BORE.**

4.5 Disassembly - *Emission-Pak* valves

NOTE: If complete disassembly becomes necessary it is recommended to replace all seats and seals. Refer to the Repair Kit chart (see **Tables 10B**).

NOTE: Always use original OEM parts to make sure that the valves functions properly.

1. Follow the steps in all the **WARNING** sections before performing any work on the valve.
2. Open and close the valve and leave it in the closed position.
3. If a handle is installed remove the handle assembly as described in **Section 4.3**.
4. If an actuator is installed remove the actuator as described in **Section 4.2**.
5. If the valve has the "leak-off" option, remove any remaining "leak-off" port fittings or plugs.
6. Remove the retaining ring (72) and grounding spring (70) from stem (4).

7. Remove hex nuts (30), disc springs (31) and compression plate (20). Pay careful attention to the orientation of the disc springs (31) and make sure they are in the same orientation during assembly.
8. Remove hex nuts (111) and lift the *Emission-Pak* housing (101) straight up until the ball end of the stem clears the valve body (1) (see **Figure 5**).

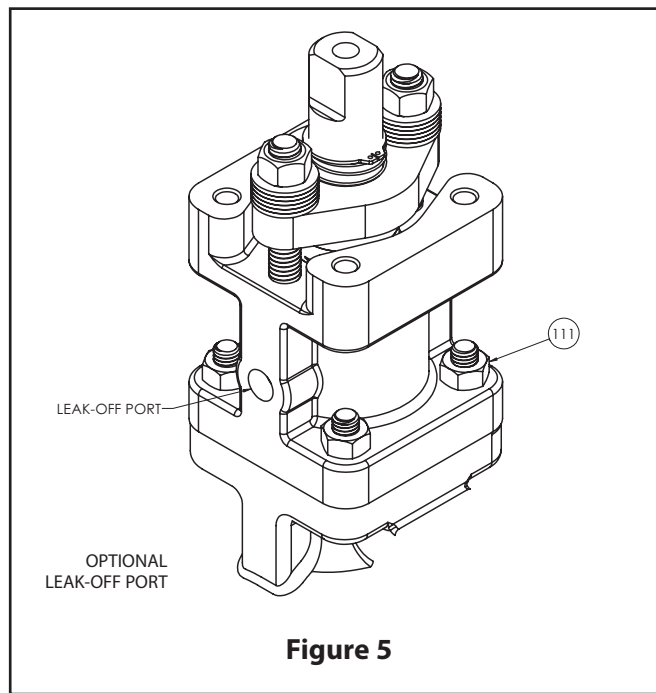

Figure 5

9. Place the valve in the vertical position with the body cap end up.
10. Mark the body joint flanges to assure correct body (1) and body cap (2) orientation during assembly. Remove body stud nuts (33) and remove body cap (2). **BE CAREFUL NOT TO SCRATCH THE BALL.**
11. Remove and discard the body seal (6) and the seat (5) from the body cap.
12. Rotate the stem (4) so that the ball is in the closed position for removal. If the ball (3) does not swing free from the body, with the ball in the fully closed position, use a piece of wood or some other soft material to gently tap the ball (from the end opposite the body cap). This should loosen the ball so that it can be pivoted free of the stem (4). The bottom grounding spring (71), located in bottom of the stem (4), may fall out at this time. If the spring does not fall out with the stem, remove it from the stem to prevent it from being lost.
13. Carefully remove and discard the bottom seat (5) out of the body, **BEING CAREFUL NOT TO SCRATCH THE BODY SEALING SURFACE BEHIND THE SEAT.**
14. From the *Emission-Pak* housing (101) remove the stem (4), stem bearings (13), secondary stem seal (7), stem seals (104), bearing strip (109) and lantern ring (103), **BEING CAREFUL NOT TO DAMAGE ANY SEALING SURFACE. Discard seals and bearing strip.**

4.6 Checking Parts

1. Clean all disassembled parts.
2. Check the stem (4) and ball (3) for damage. Pay particular attention to the sealing areas.
3. Check all sealing and gasket surfaces of the body (1) and body cap (2).
4. Replace any damaged parts.
5. Replace any fastener where the threads are damaged or have been heated, stretched or corroded.
6. Replace any parts that have cracks, gouges or pits that will affect sealing.

NOTE: When ordering spare parts, always include the following information:

- a. Valve catalog code from Identification plate,
- b. If the valve is serialized – the serial number (stamped on the valve body or identification plate),
- c. From **Figure 18 or 19**, the ballooned part number, part name and quantity required.

4.7 Assembly – bare stem valves

It is advisable to replace seats and seals if complete disassembly and reassembly become necessary. Refer to the Repair Kit chart (see **Table 10A**).

1. Clean all valve components if not done previously.
2. With a wire brush, clean studs (29) and stud nuts (30) of foreign material, such as paint, thread locker, grime and commodity. Inspect the threads for damage or defects with appropriate ring or plug gauge. Repair any out-of-tolerance threads, or replace in-kind. Check that nut can be run up and down entire usable portion of the threads (See **Figure 18 or 19**).
3. Re-inspect all components for damage before reassembling the valve. Look for damage to the seating areas, stem, body and insert; and look for wear in the bearing areas. Replace any damaged parts.
4. Carefully clean and polish the ball (3) sealing surface: It should be free of all scratches and grooves.
5. If the ball is slightly damaged, it may be possible to smooth the sealing surface with crocus cloth or equivalent. If deep scratches are present, replace the ball.

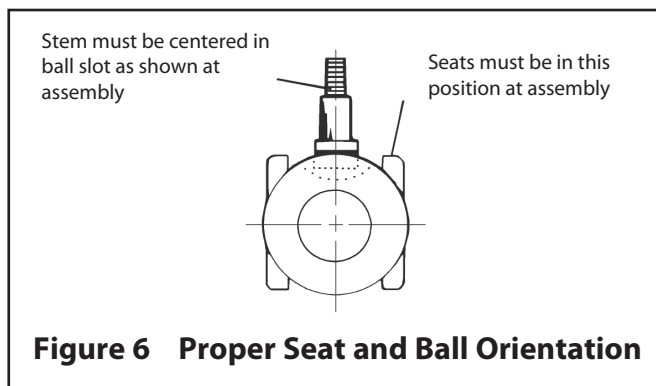

6. Place the body and body cap carefully on the pipeline flange, on a soft surface, taking care not to damage the raised face sealing surface. With the body cap side facing up, slide one valve seat (5) sideways into the body (1) to below the stem bore, and tilt it into place so that the proper surface (see **Figure 6**) will be adjacent to the ball (3), being careful not to cut or scratch the seat.
7. From inside the body (1), insert the one thrust bearing (13), the secondary stem seal (7), and the second thrust bearings (13) into the stem bore (see **Figure 7**).
8. Insert the stem (4) through the body cap end of the body (1), being careful not to scratch the stem sealing surface; and press it gently up into the stem bore until resistance is felt from the thrust bearing. Hold the stem in place from the bottom and insert the stem seals (8) (see **Figure 8** for proper v-ring orientation), over the stem (4).

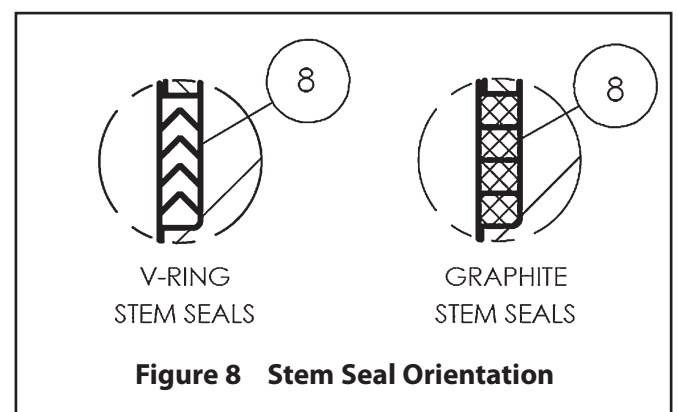
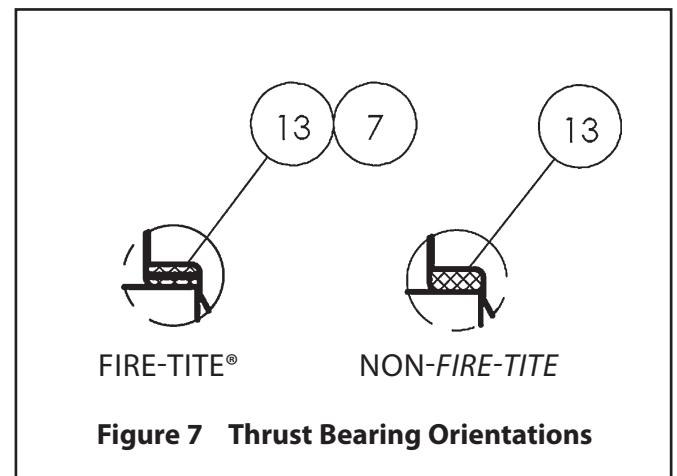

9. Place compression plate (20) over studs (29). Place two disc springs (31) over each stud (see **Figure 9** for proper orientation).
10. A lubricant compatible with the flow media **MUST** be applied to the stud (29) threads and the face of the stud nut (30). Place a stud nut (30) on each stud (29) and tighten nuts alternately so that the compression plate (20) remains parallel with the body bonnet. Tighten the stud nuts in accordance with the torque values in **Table 1**.

TABLE 1							
Bonnet Stud Nut Torque (Standard Valve)							
Size	Series	V-RING STEM SEALS			GRAPHITE STEM SEALS		
		ft-lbs	In-lbs	N-m	ft-lbs	In-lbs	N-m
2	9150/9180	4	48	5.4	8	96	11
2	9300/9380	4	48	5.4	8	96	11
3	9150/9180	4	48	5.4	8	96	11
3	9300/9380	8	96	11	18	216	24.5
4	9150/9180	8	96	11	18	216	24.5
4	9300/9380	11	132	15	24	288	32.5
6	9150/9180	11	132	15	24	288	32.5
8	7150/7180	11	132	15	24	288	32.5

11. With a wire brush, clean body studs (32) and body stud nuts (33) of foreign material, such as paint, thread locker, grime and commodity. Inspect the threads for damage or defects with appropriate ring or plug gauge. Repair any out-of-tolerance threads, or replace in-kind. Check that nut can be run up and down entire usable portion of the threads. (See **Figure 16**)
12. Insert internal grounding spring (71) into hole at the bottom of the stem (4). Insert the ball (3) rotating it onto the stem (4) in the closed position. If necessary, turn the stem blade to align with the ball slot. Make certain that the stem blade is in the middle of the ball slot; i.e. equal distance from the ends of the slot. Rotate the ball if necessary (see **Figure 6**).
13. Gently place the body seal (6) into the machined recess of the body (1).
14. Place the second seat (5) on top of the ball (3) with the proper surface (see **Figure 6**) adjacent to the ball.
15. Place the body cap (2) over body studs (32) being careful to properly orient body cap and body as originally assembled by matching orientation marks made prior to disassembly. Take care not to damage body seal (6) or seat (5) during this operation.
16. Lubricate the threads and face of nuts (33) with NeverSeez® or equivalent. Install nuts (33) on body studs (32) and tighten sequentially as shown in the diagram (**Figure 10**), to the recommended torques as shown in the torque chart (**Table 2**).

NOTE: Always install body stud nuts (33) so that the fastener grade markings will be visible following assembly.

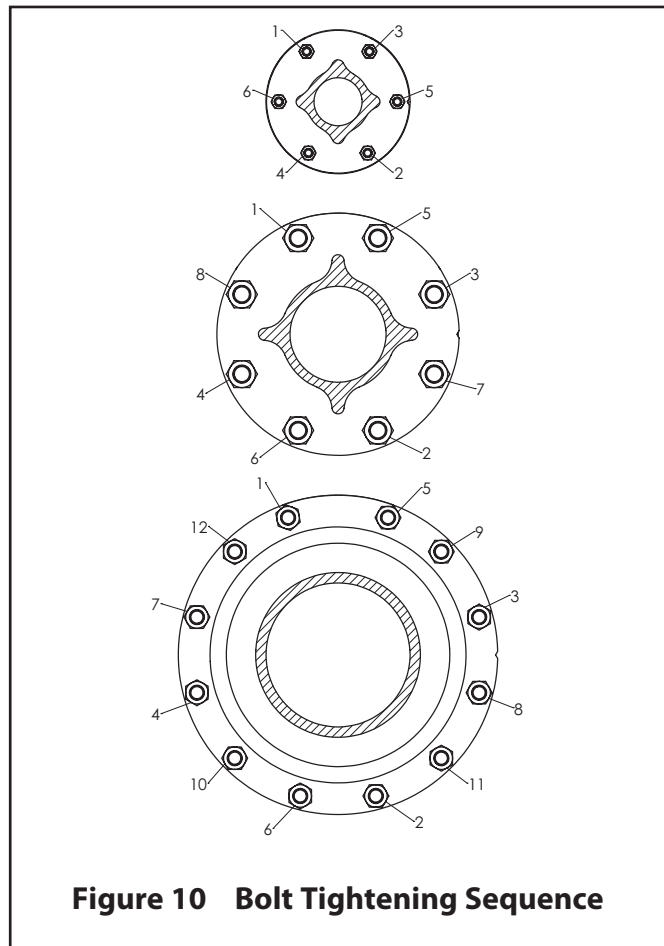
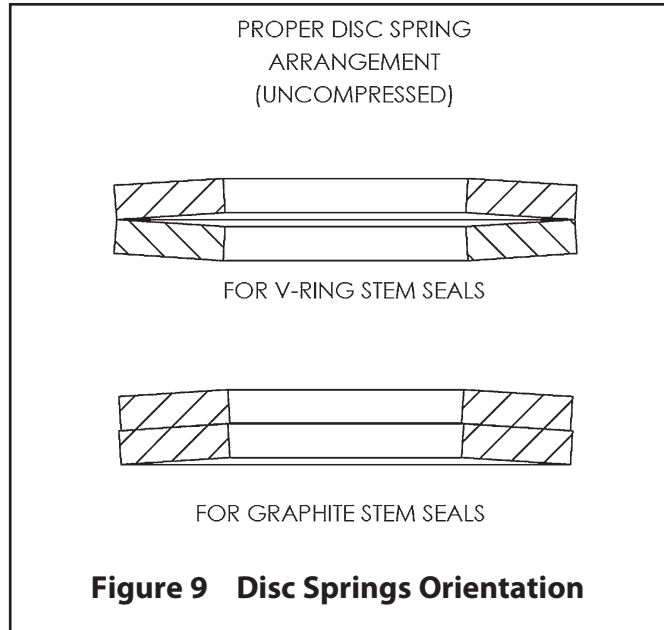

17. Cycle the valve slowly with a gentle back and forth motion building gradually to the full quarter turn. By cycling slowly, the seat lips will seat against the ball. Take care to avoid scratching the ball O.D.
18. Replace top grounding spring (70) and retaining ring (72) to stem (4).

TABLE 2				
Lubricated Torques - ft·lbs (N·m)				
Fastener Size	Fastener Material			
	A193 GR. B7	A193 GR. B8	A193 GR. B7M	A193 GR. B8M
	Fastener Identification Mark			
	B7	B8	B7M	B8M
3/8 - 16 UNC	30 - 38 (40 - 51)	24 - 29 (32 - 39)	23 - 29 (31 - 39)	27 - 35 (37 - 47)
1/2 - 13 UNC	75 - 93 (101 - 126)	57 - 70 (77 - 95)	57 - 71 (77 - 96)	68 - 84 (92 - 114)
5/8 - 11 UNC	150 - 190 (203 - 257)	110 - 140 (149 - 189)	110 - 140 (149 - 189)	130 - 170 (176 - 230)
3/4 - 10 UNC	260 - 330 (352 - 446)	200 - 250 (271 - 338)	200 - 250 (271 - 338)	240 - 300 (325 - 406)

4.8 Assembly - Emission-Pak valve

It is advisable to replace seats and all seals if complete disassembly becomes necessary. Refer to Repair Kit chart (see **Table 10B**).

- Clean all valve components if not done previously.
- With a wire brush, clean body studs (32) and stud nuts (33) of foreign material, such as paint, thread locker, grime and commodity. Inspect the threads for damage or defects with appropriate ring or plug gauge. Repair any out-of-tolerance threads, or replace in-kind. Check that nut can be run up and down entire usable portion of the threads (See **Figure 19**).
- Re-inspect all components for damage before reassembling the valve. Look for damage to the seating areas, stem, body and insert; and look for wear in the bearing areas. Replace any damaged parts.
- Carefully clean and polish the ball (3) sealing surface: It should be free of all scratches and grooves.
- If the ball is slightly damaged, it may be possible to smooth the sealing surface with crocus cloth or equivalent. If deep scratches are present, replace the ball.
- With the body cap side facing up, slide one valve seat (5) sideways into the body (1) to below the stem bore, and tilt it into place so that the proper surface (see **Figure 6**) will be adjacent to the ball (3), being careful not to cut or scratch the seat.
- Insert new bearing strip (109) into recess inside lower stem bore of *Emission-Pak* housing (101) (see **Figure 19**).
- Place inner and outer stem retainer seals (105) and (106) on the *Emission-Pak* housing (111) shown in (**Figure 19**).
- Slide one thrust bearing (13), the secondary stem seal (7) and the second thrust bearing (13) over the stem (4) (see **Figure 7** for proper orientation).
- Insert the stem subassembly into the *Emission-Pak* housing (101). Pull the stem outward to seat the thrust bearings. Install one set of stem seals (104) and lantern ring/spacer (103) over the stem as shown in (**Figure 8**). For optimal performance, pre-compress the first set of stem seals.

- Install the compression ring (111) and compression plate (20) over the stem. Using stud nut (30), apply the torque value listed in (**Table 3**).
- Remove the stud nuts (30), compression plate (20), and compression ring (110) from *Emission-Pak* housing.
- Install the top set of stem seals (104) over the stem as shown in (**Figure 8**).
- Hold the stem in place and slide the compression ring (111) and compression plate (20) over the stem (4) and studs (29).
- Place the disc springs (31) over each stud (29) (see **Figure 19** for proper orientation). A lubricant, compatible with the flow media, **MUST** be applied to the stud (29) threads and the face of the stud nut (30).
- Place the stud nut (30) on each stud (29) and tighten nuts a few turns alternately so that the compression plate (20) remains parallel with the body bonnet. Do not fully torque down stud nuts (30) at this time.
- Insert the *Emission-Pak* subassembly into the body, being careful not to damage the *Emission-Pak* housing seals. A lubricant, compatible with the flow media, **MUST** be applied to the stud (102) threads and the face of the nut (111).
- It is recommended for optimal performance to press the *Emission-Pak* subassembly fully into the body so the body bonnet and the bottom flange surface of the *Emission-Pak* subassembly are metal to metal contact. Recommended press loads can be found in (**Table 4**).
- Once metal to metal contact has been achieved, tighten the nuts (111) to the torque values in (**Table 5**). Apply the torque evenly in a crisscross pattern.
- Place the valve in a vertical position, insert end up, on a clean soft surface such as a folded rag or a piece of cardboard. If the valve has grounded option, insert the bottom grounding spring (71) into the hole at the bottom of the stem (4). Insert the ball (3) rotating it onto the stem (4) in the closed position. If necessary, turn the stem blade to align with the ball slot. Make certain that the stem blade is in the middle of the ball slot; i.e. equal distance from the ends of the slot. Rotate the ball if necessary (see **Figure 6**).

TABLE 3							
Bonnet Stud Nut Torque (<i>Emission-Pak</i> Valve)							
Size	Series	V-RING STEM SEALS			GRAPHITE STEM SEALS		
		ft-lbs	In-lbs	N-m	ft-lbs	In-lbs	N-m
2	9150/9180	8	96	11	16	192	22
2	9300/9380	8	96	11	16	192	22
3	9150/9180	8	96	11	16	192	22
3	9300/9380	15	180	20	36	432	49
4	9150/9180	15	180	20	36	432	49
4	9300/9380	22	264	30	48	576	65
6	9150/9180	22	264	30	48	576	65
8	7150/7180	22	264	30	48	576	65

TABLE 4			
Emission-Pak Housing Press Load			
Size	Series	Minimum Load	Maximum Load
		tons	tons
2	9150/9180	8	10
2	9300/9380	8	10
3	9150/9180	8	10
3	9300/9380	10	12
4	9150/9180	10	12
4	9300/9380	10	12
6	9150/9180	10	12
8	7150/7180	10	12

TABLE 5					
Emission-Pak Housing Nut Torques					
Lubricated Torques ft-lbs (N-m)					
Fastener Size	A193 GR. B7	A193 GR. B8	A193 GR. B7M	B473 UNS N08020	QQ-N-286
	Fastener Identification Mark				
	B7	B8	B7M	35	K or 71
M8	21 – 26	20 – 25	16 – 20	12 – 15	17 – 21
	(29 – 35)	(27 – 34)	(22 – 27)	(16 – 20)	(23 – 28)
M10	42 – 51	40 – 49	32 – 39	24 – 29	34 – 41
	(57 – 69)	(54 – 67)	(43 – 53)	(32 – 39)	(46 – 56)
M12	73 – 89	69 – 85	56 – 68	42 – 51	59 – 72
	(99 – 121)	(93 – 115)	(76 – 92)	(57 – 70)	(80 – 98)

- Gently place the body seal (6) into the machined recess of the body (1).
 - Place the second seat (5) on top of the ball (3) with the proper surface (see **Figure 6**) adjacent to the ball.
 - Place the body cap (2) over body studs (32) being careful to properly orient body cap and body as originally assembled by matching orientation marks made prior to disassembly. Take care not to damage body seal (6) or seat (5) during this operation.
 - Lubricate the threads and face of nuts (33) with NeverSeez® or equivalent. Install nuts (33) on body studs (32) and tighten sequentially as shown in the diagram (**Figure 10**), to the recommended torques as shown in the torque chart (**Table 2**).
- NOTE:** Always install body stud nuts (33) so that the fastener grade markings will be visible following assembly.
- While pulling the stem (4) outward, tighten the hex nuts (30) to the torque values in (**Table 3**). Apply the torque evenly, alternating between the two nuts so that the compression plate (20) remain parallel with the *Emission-Pak* housing bonnet.
 - Cycle the valve slowly with a gentle back and forth motion building gradually to the full quarter turn. By cycling slowly, the seat lips will seat against the ball. Take care to avoid scratching the ball O.D.
 - Replace top grounding spring (70) and retaining ring (72) to stem (4).

4.9 Testing the Valve

WARNING:

WHEN PRESSURE TESTING, EXERCISE CAUTION AND MAKE SURE ALL EQUIPMENT USED IS IN GOOD WORKING CONDITION AND APPROPRIATE FOR THE INTENDED PRESSURE.

If the valve is to be tested prior to returning to service make sure the test pressures are in accordance with an applicable standard.

When testing the valve for external tightness, keep the ball in the half open position.

If testing the valve seat tightness, please contact Neles for advice.

WARNING:

WHEN PERFORMING ANY TESTS, NEVER EXCEED THE MAXIMUM OPERATING PRESSURE OR MAXIMUM SHUT-OFF PRESSURE LISTED ON THE IDENTIFICATION PLATE!

5 HANDLE MOUNTING

- Stroke the valve to the fully open position.
 - Lower the handle bracket (2) straight down in line with the valve stem until it is flat on the valve bonnet, and all four mounting holes align with tapped holes on the valve (see **Figure 11**).
- NOTE:** Positive stop feature on handle bracket (2) should be forward, towards the body cap.
- Insert the four bracket screws (3) and lock washers (4) into the mounting holes and thread into the valve until finger tight only.
 - Aligning the slot in the handle with drive on the stem, lower handle (1) straight down in line with the valve stem until it is completely engaged. If the handle (1) interferes with the handle bracket (2) rotate the handle bracket slightly to remove interference. DO NOT rotate stem!

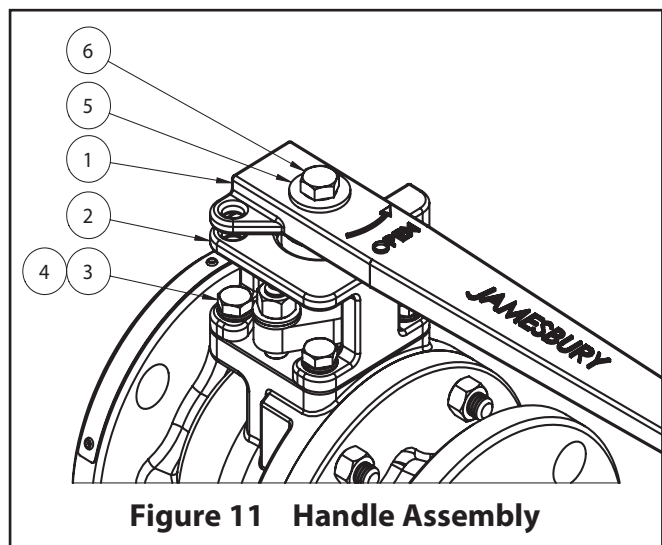

Figure 11 Handle Assembly

NOTE: When looking down at the top of the valve, the cast lettering and “OPEN” arrow on the handle should be visible. If they are not visible the handle is installed upside down.

5. Install the handle screw (6) and washer (5). Tighten handle screw (6) to value listed in **Table 6**.
6. Confirm ball is in fully open position. Adjust if necessary.
7. Rotate handle bracket (2) until the handle stop contacts the side of the handle (1) (see **Figure 12**).

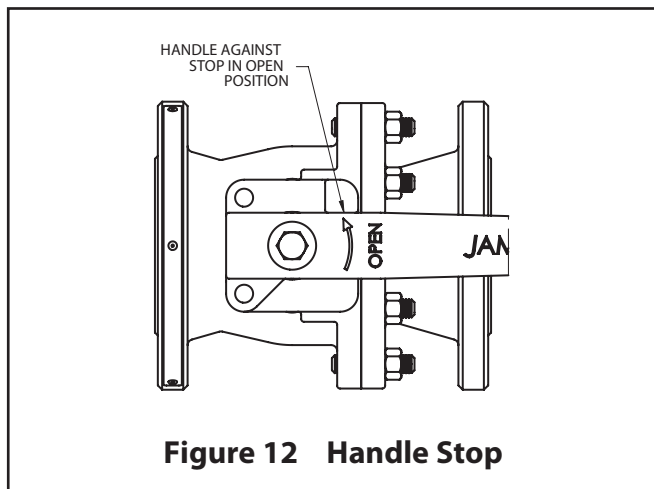

Figure 12 Handle Stop

8. Tighten the four bracket screws (3) to the values listed in **Table 6**.
9. Close, and then open the valve making sure the handle is against the handle bracket stop. Check the ball to confirm full open position. If the ball is not in the full open position with the handle against the stop, loosen the four bracket screws (3) and make any necessary adjustments by rotating the handle bracket. Retighten the four bracket screws (3) to the values listed in **Table 6**.

6 STEM EXTENSION MOUNTING

1. Stroke the valve to the fully open position.
2. Lower the handle stop (2) straight down in line with the valve stem until it is flat on the valve bonnet, and both mounting holes align with tapped holes on the valve (see **Figure 13**). **NOTE:** The stop should be mounted rearward on the bonnet, between the stem and body pipeline flange. The curved side should be towards the stem.
3. Insert the stop screws (3) and lock washers (4) into the mounting holes and thread into the valve until finger tight only.
4. Screw threaded rod (5) into tapped hole on top of stem.
5. Aligning the slot in the stem extension (1) with drive on the stem, lower the stem extension straight down over the threaded rod (5) and in line with the valve stem until it is completely engaged. If the stem extension (1) interferes with the stop (2), move the stop slightly to remove interference. DO NOT rotate stem!

6. Aligning the slot in the handle with drive on the stem extension (1), lower the handle straight down over the threaded rod (5) and in line with the stem extension drive until it is completely engaged. **NOTE:** When looking down at the top of the valve, the cast lettering and “OPEN” arrow on the handle should be visible. If they are not visible the handle is installed upside down.
7. Install the washer (7) over the threaded rod onto the handle. Thread handle nut (6) onto threaded rod and tighten handle nut (6) to torque value listed in **Table 6**.
8. Confirm ball is in fully open position.
9. Rotate stop (2) until the stop contacts the side of the stem extension stop boss (1) (see **Figure 13**).

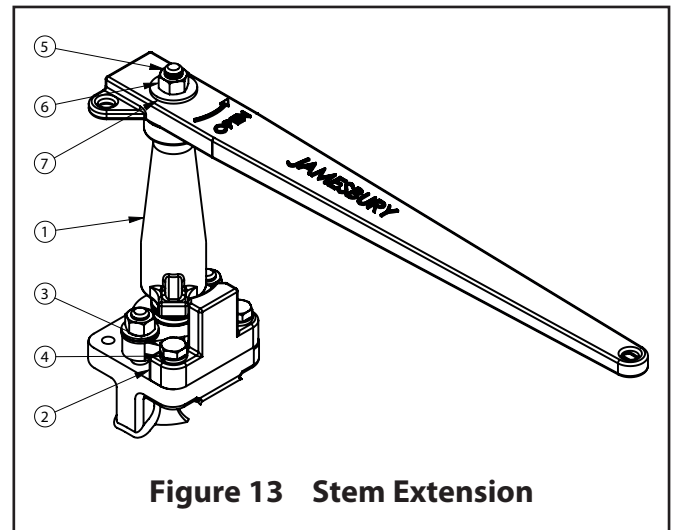

Figure 13 Stem Extension

10. Tighten the stop screws (3) to the values listed in **Table 6**.
11. Close, and then open the valve making sure the stem extension is against the stop. Check the ball to confirm full open position. If the ball is not in the full open position with the stem extension against the stop, loosen the stop screws (3) and make any necessary adjustments by rotating the stop (2). Retighten the stop screws (3) to the values listed in **Table 6**.

7 ACTUATOR MOUNTING

When these valves are equipped with an actuator, and the actuator is removed to service the valve, proper alignment of the actuator driver and valve stem is essential when the actuator is remounted.

7.1 General

These actuator mounting instructions describe the steps required to assemble the *Jamesbury* 2", 3", 4", 6" & 8" (DN 50, 80, 100, 150 & 200) ASME Class 150; and the 2", 3", 4", 6" & 8" (DN50, 80,100, 150 & 250) ASME Class 300, Full Bore, Non-trunnion Series 9000 Model C; and the 8" & 10" (DN200 & 250) ASME Class 150, 8" & 10" (DN200 & 250) ASME Class 300, Standard Bore, Non-trunnion Series 7000 Model C standard and *Emission-Pak* Flanged Ball Valves to actuators. Linkage kits that are needed to mount specific Neles actuators to different types and sizes of *Jamesbury* valves can be identified by Neles or your authorized Neles Distributor.

WARNING:

FOR YOUR SAFETY IT IS IMPORTANT THAT THE FOLLOWING PRECAUTIONS BE TAKEN!

BEFORE INSTALLING THE VALVE AND ACTUATOR, BE SURE THE INDICATOR POINTER ON TOP OF THE ACTUATOR IS CORRECTLY INDICATING THE VALVE'S POSITION. FAILURE TO ASSEMBLE THESE TO INDICATE THE CORRECT VALVE POSITION COULD RESULT IN DAMAGE OR PERSONAL INJURY!

WHEN INSTALLING A LINKAGE KIT OR SERVICING THE VALVE/ACTUATOR ASSEMBLY, THE BEST PRACTICE IS TO REMOVE THE ENTIRE ASSEMBLY FROM SERVICE!

AN ACTUATOR SHOULD BE REMOUNTED ON THE SAME VALVE FROM WHICH IT WAS REMOVED. THE ACTUATOR MUST BE ADJUSTED FOR THE PROPER "OPEN" AND "CLOSE" POSITIONS EACH TIME IT IS REMOVED!

THE LINKAGE KITS HAVE BEEN DESIGNED TO SUPPORT THE WEIGHT OF THE NELES ACTUATOR AND RECOMMENDED ACCESSORIES. USE OF THE LINKAGE TO SUPPORT ADDITIONAL EQUIPMENT OR ADDITIONAL WEIGHT SUCH AS PEOPLE, LADDERS, ETC., MAY RESULT IN THE FAILURE OF THE LINKAGE, VALVE, OR ACTUATOR; AND MAY CAUSE DAMAGE OR PERSONAL INJURY!

7.2 Valve Preparation

1. With the valve removed from the pipeline, turn the valve to the closed position.
2. On valves with handles, remove the handle, handle bracket, and any accessories that may be attached to the bonnet surface. DO NOT loosen the stud nuts (30), see (Figure 18 or 19).

7.3 Bracket Preparation – (see Figure 14)

1. Roll the bearing strip (3) about its length into a circular shape.
2. Place the bearing strip (3) into round opening in the top center of the bracket (2). Ends of the bearing must not overlap.

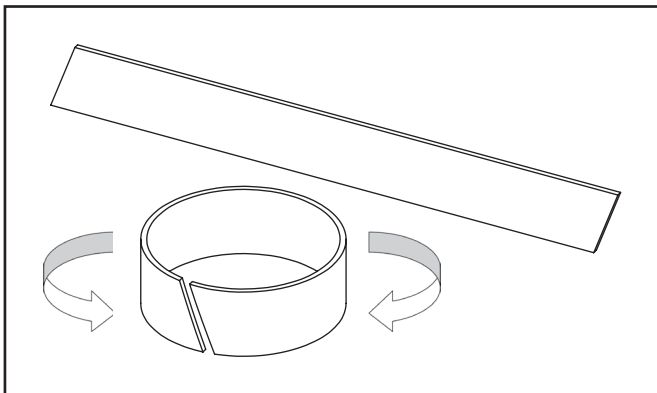

3. Slide the bearing (3) into the bracket (2) until about half of its width is protruding from the bottom of the top bracket flange.
4. Inspect the coupling (1) and locate the end that will engage the actuator.

5. Insert the actuator end of the coupling (1) from the bottom of the bracket (2) into the protruding bearing (3).

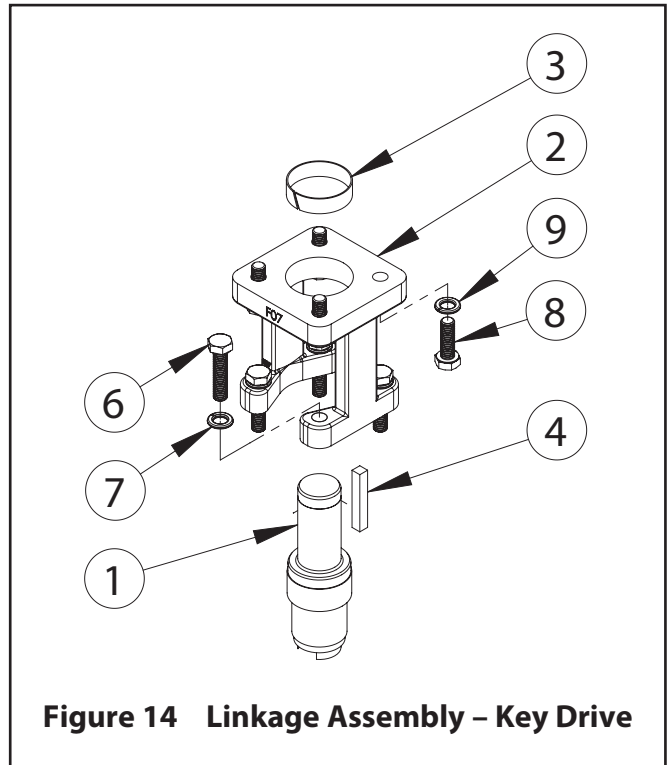

Figure 14 Linkage Assembly – Key Drive

6. Press the coupling (1) upward until the bearing (3) sits flush on the bearing shoulder of the coupling (1) and is flush with the top flange of the bracket (2). (See Figure 15)

7.4 Bracket Attachment to Valve

1. Lower the bracket/coupling assembly on the valve, aligning the slot in the bottom of the coupling (1) with top of the valve stem.
2. Align the four bracket mounting screw holes with the tapped holes on the valve bonnet.
3. Insert the four hex head cap screws (6) and lockwashers (7) into the tapped holes. Tighten to values in Table 6.

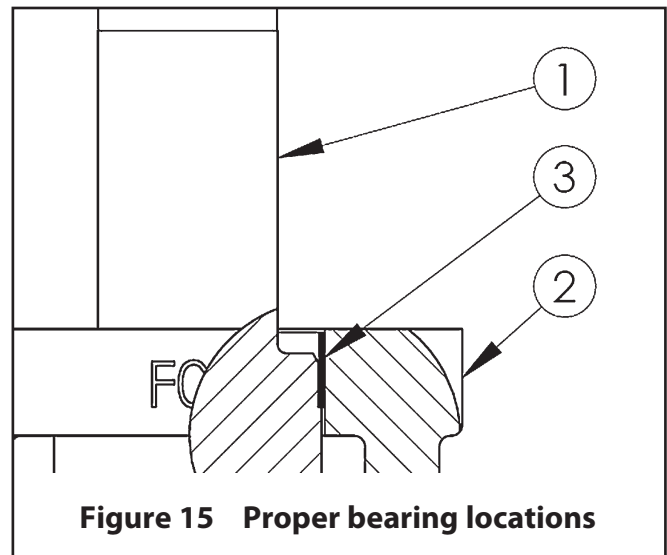

Figure 15 Proper bearing locations

7.5 Actuator versus Valve Position

IMPORTANT: The actuator and valve position must agree before further assembly.

Since the valve has already been set in the closed position (Step 1 under Valve Preparation), make sure that the actuator is also in the closed position. **EXCEPTION:** If mounting a spring-return actuator for “spring-to-open” operation; cycle the valve to the open position and proceed with the actuator AND valve in the open position.

7.6 Coupling to Actuator

Key Drive Actuators (Figure 14): Install the key (4) into the key slot of the coupling (1). The key should be filed to closely fit into coupling and actuator keyway. If the fit is loose, apply Loctite® Keyfit or equivalent.

Male/Female Square Drive Actuators (Figure 16): No coupling prep required.

7.7 Bracket Attachment to Actuator

- For QPX1/M, QPX2/M, QPX4/M and QPX5/M; and Torq-Handle® A and B actuators, attach adapter plate (5) to the actuator using the four socket head cap screws (10). Tighten fasteners to values in **Table 6**.

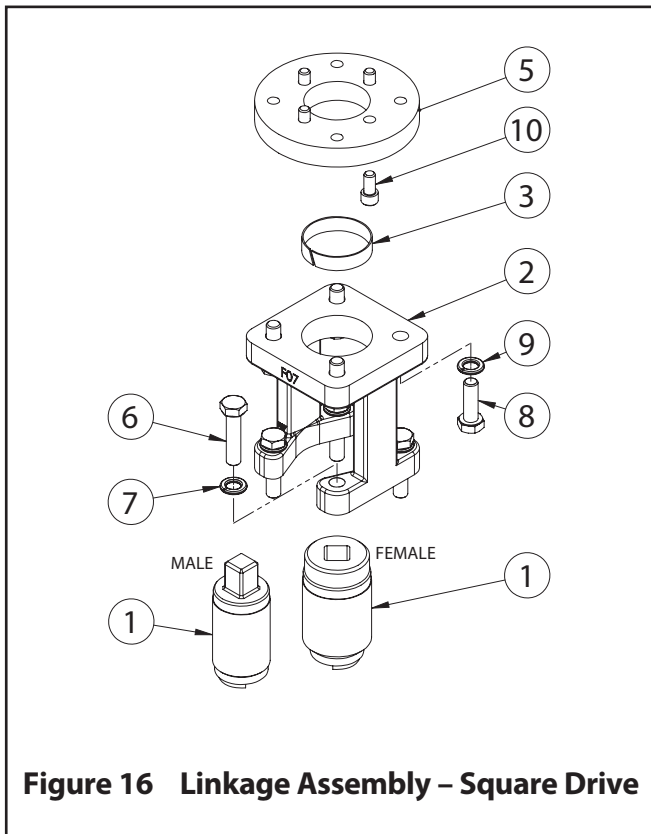

Figure 16 Linkage Assembly – Square Drive

TABLE 6			
Bolt Size	Torque to Cast/Ductile Body Actuators		
	No Lubrication		
	ft·lbs	in·lbs	N·m
1/4	8	96	11
5/16	16	192	22
3/8	27	324	37
7/16	45	540	61
1/2	67	804	91
9/16	100	1200	136
5/8	135	1620	183
3/4	225	2700	305
7/8	335	4020	454
1	520	6240	705
1-1/8	700	8400	949
1-1/4	990	11880	1342
M6	7	84	9
M8	14	168	19
M10	28	336	38
M12	48	576	65
M16	115	1380	156
M20	225	2700	305
M30	783	9396	1062
M36	1347	16164	1826

- Place the actuator onto the valve and bracket assembly aligning the holes in the bracket with the holes in the actuator, and aligning the actuator drive with the coupling. Install the four hex head cap screws (8) and four lockwashers (9) through the bracket and into the actuator. Apply slightly more than finger-tightness to these fasteners, but **DO NOT TIGHTEN**.
- Cycle the actuator a couple of times, allowing the assembly to position itself for proper actuator-drive to valve-drive alignment. Tighten the four hex head cap screws (8) securing the bracket to the actuator using the values in **Table 6 or 7** as applicable.

WARNING:

BEWARE OF BALL MOVEMENT!

KEEP HANDS, OTHER PARTS OF THE BODY, TOOLS AND OTHER OBJECTS OUT OF THE OPEN FLOW PORT. LEAVE NO FOREIGN OBJECTS INSIDE THE VALVE. WHEN THE VALVE IS ACTUATED, THE BALL FUNCTIONS AS A CUTTING DEVICE.

7.8 Open/Close Position Adjustment

NOTE: Refer to the appropriate Installation, Maintenance, and Operating Instructions (IMO) for specific directions on how to adjust the actuator travel stops or limit switch (see **Table 8**).

The actuator travel stops should be adjusted so that there is proper ball position in the full open and full close valve position. Use the following procedures to determine correct ball position.

Valve Open Position: With the valve in the open position (actuator is against the “OPEN” travel stop), The maximum allowable misalignment of the ball port in relation to the body port is 1/16 inch (1.6 mm) on either side of the ball. Do not use the seat ID to measure misalignment since, in many cases; it is larger than the ball or body port.

Valve Close Position: With the valve in the closed position (actuator is against the “CLOSE” travel stop), make a pencil mark on the ball at the 9:00 o’clock and 3:00 o’clock locations as shown in **(Figure 17)**. Open the valve part way, and measure dimension “A”. This measurement should deviate no more than $\pm 1/16$ inch (± 1.6 mm) from the value given in **(Table 9)** for all valves.

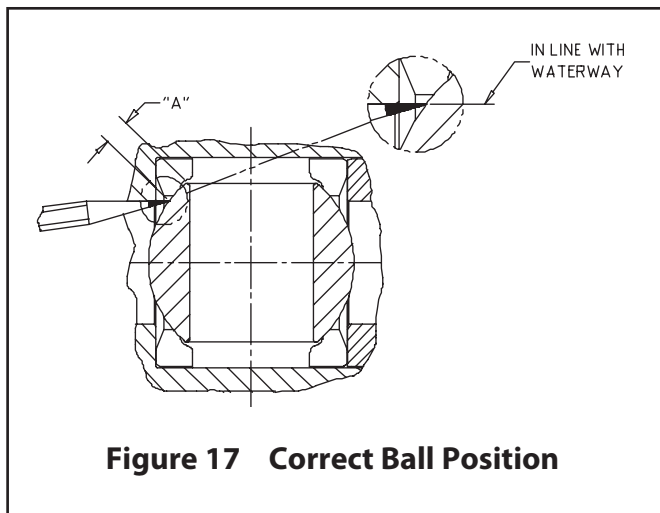

Figure 17 Correct Ball Position

TABLE 7			
Bolt Size	Torque to Aluminum Body Actuators		
	No Lubrication		
	ft-lbs	in·	N·m
1/4	6	72	8
5/16	12	144	16
3/8	20	240	27
7/16	30	360	41
1/2	50	600	68
9/16	70	840	95
5/8	90	1080	122
3/4	160	1920	217
7/8	250	3000	339
1	360	4320	488
1-1/8	520	6240	705
1-1/4	700	8400	949
M6	5	60	7
M8	11	132	15
M10	22	264	30
M12	38	456	52
M16	90	1080	122
M20	170	2040	230
M30	570	6840	773
M36	950	11400	1288

TABLE 8	
Actuator Installation, Maintenance and Operating Instructions	
Actuator	IMO
QPX	215
VPVL	553
B1C	6 BC 71
B1J	6 BJ 71
BCH	6 BCH 70
M	549
ADC	I4400, I4500 or I4600
ESR	I7016
I	I6500, I6600 or I6700
LCR	I1262
LCU	I1263
Q6	I1227 or I1383
QX	I3000
V	I2100, I2475, I2500, I2700 or I5500
TORQ-HANDLE	71

Contact your authorized Neles Distributor for copies of these instructions

TABLE 9	
Dimension “A” for Valve Closed Position Adjustment	
Valve Size	Dimension “A” - inch (mm)
2” (DN50) 9000	3/8 (9.53)
3” (DN80) 9000	1/2 (12.7)
4” (DN 100) 9000	3/4 (19.1)
6” (DN 150) 9000 8” (DN 200) 7000	1-1/16 (27)
8” (DN200) 9000	
10” (DN250) 7000	

8 SERVICE/SPARE PART

We recommend that valves be directed to our service centers for maintenance. The service centers are equipped to provide rapid turn-around at a reasonable cost and offer new valve warranty with all reconditioned valves.

NOTE: When sending goods to the service center for repair, do not disassemble them. Clean the valve carefully and flush the valve internals. Include the material safety datasheet(s) (MSDS) for all media flowing through the valve. Valves sent to the service center without MSDS datasheet(s) will not be accepted.

For further information on spare parts and service or assistance visit our web-site at www.neles.com/valves.

NOTE: When ordering spare parts, always include the following information:

- Valve catalog code from identification plate,
- If the valve is serialized – the serial number (from identification plate)
- From **Figure 18 or 19**, the ballooned part number, part name and quantity required

Item No.	Description	Qty.
1	BODY	1
2	BODY CAP	1
3	BALL	1
4	STEM	1
5	SEAT	2
6	BODY SEAL	1
7	SECONDARY STEM SEAL*	1
8	STEM SEAL	1
Item No.	Description	Qty.
13	STEM BEARING	2
20	COMPRESSION PLATE	1
22	IDENTIFICATION TAG	1
23	POP RIVET	3
24	STEM BEARING	1
29	STUD	2
30	STUD NUT	2
31	DISC SPRING	4
32	BODY STUD	6
33	BODY STUD NUT	6
70	TOP GROUNDING SPRING	1
71	BOTTOM GROUNDING SPRING	1
72	RETAINING RING	1

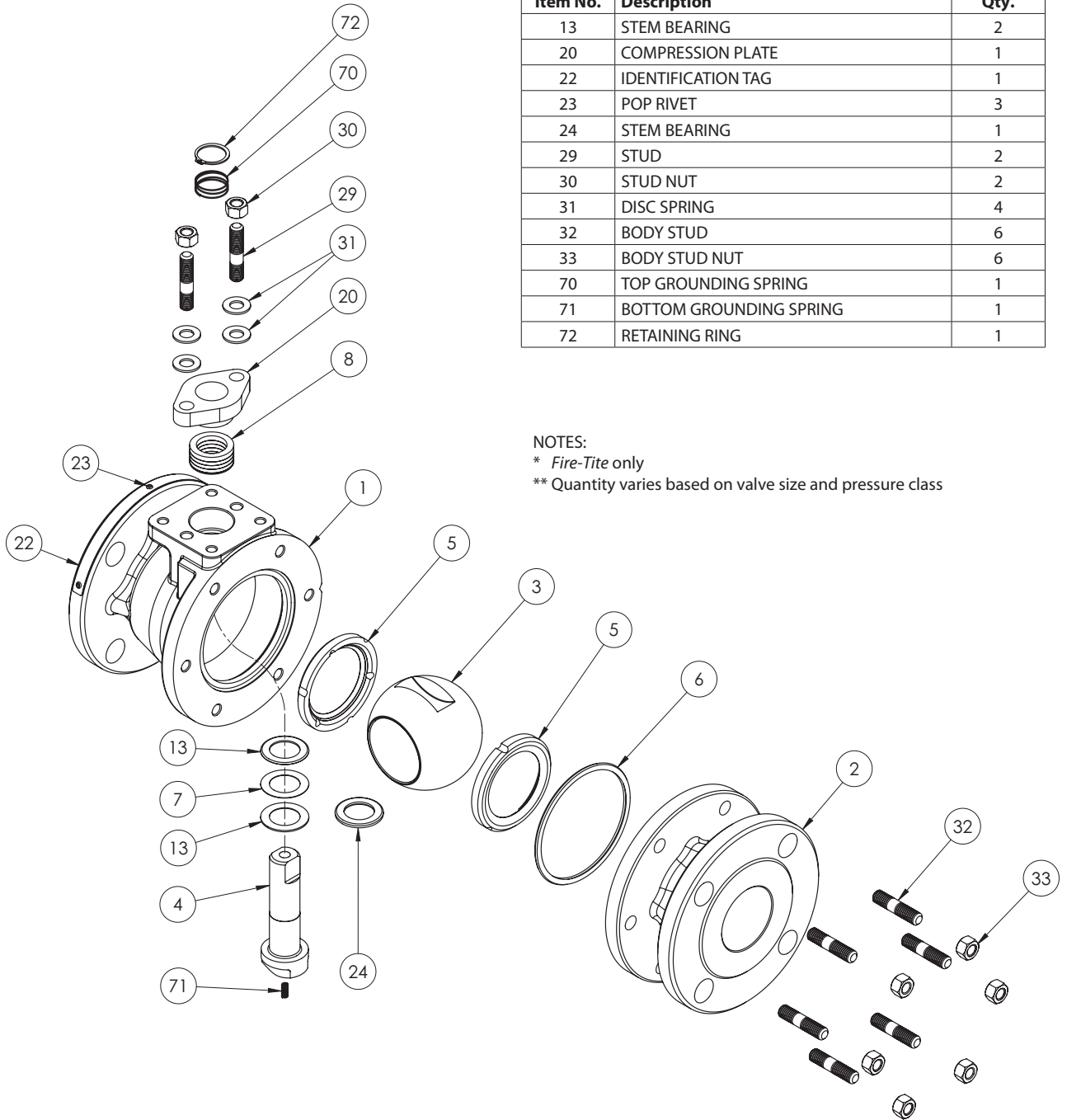

NOTES:

* Fire-Tite only

** Quantity varies based on valve size and pressure class

Figure 18

PARTS LIST		
ITEM NO	PART DESCRIPTION	QTY.
4	STEM	1
7	SECONDARY STEM SEAL	1
13	THRUST BEARING <i>FIRE-TITE</i>	2
20	COMPRESSION PLATE	1
24	THRUST BEARING NON <i>FIRE-TITE</i>	1
29	STUD	2
30	STUD NUT	2
31	DISC SPRING	12
70	TOP GROUNDING SPRING	1
71	BOTTOM GROUNDING SPRING	1
72	RETAINING RING	1
101	<i>EMISSION-PAK</i> STEM RETAINER	1
102	STUD	4
103	LANTERN RING/SPACER	1
104	STEM SEAL	2
105	STEM RETAINER SEAL INNER	1
106	STEM RETAINER SEAL OUTER	1
109	BEARING	1
110	COMPRESSION RING	1
111	HEX NUT	4
112	INSTRUCTIONAL TAG	1
115	PLASTIC PIPE PLUG	1

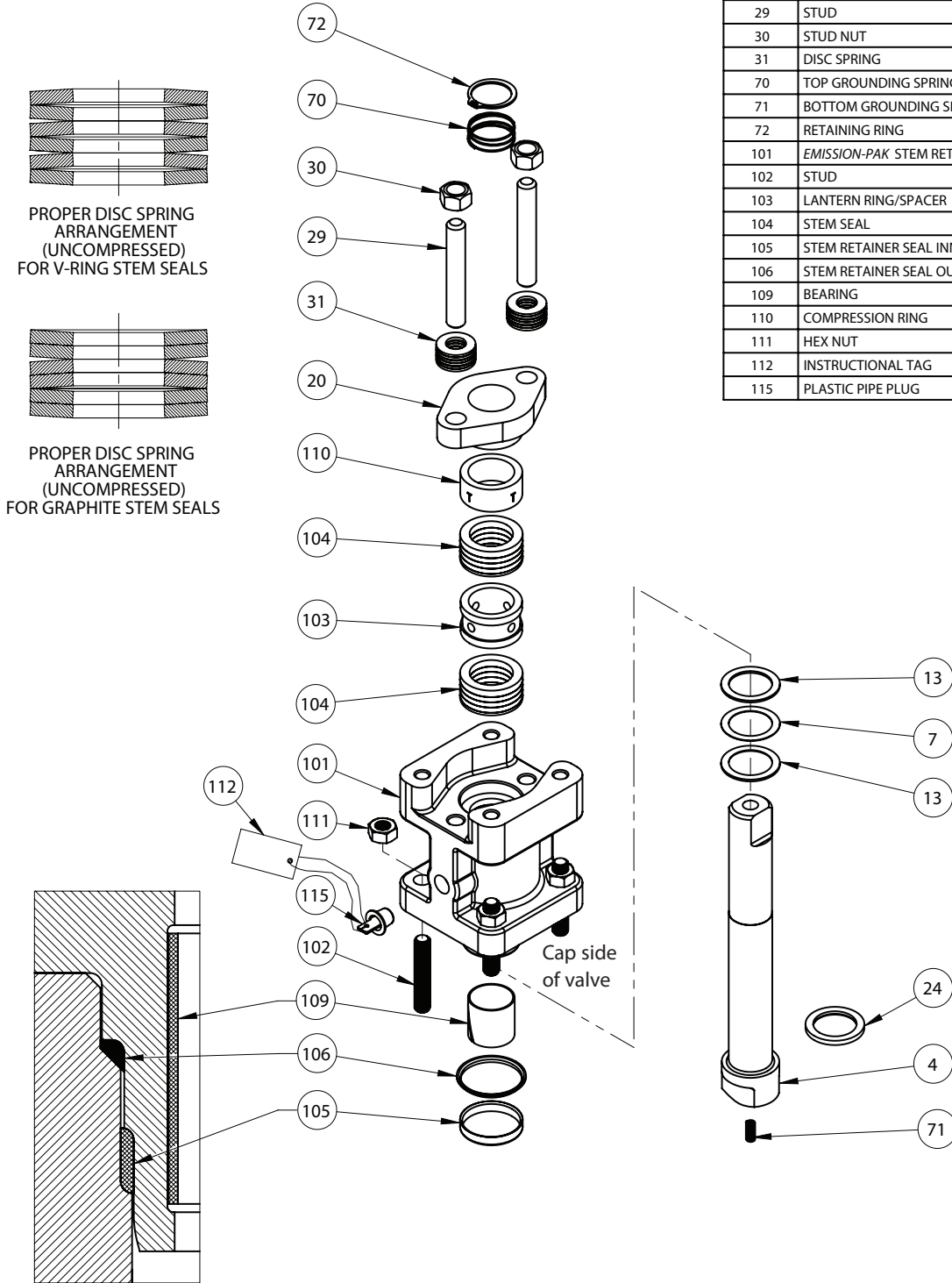

Figure 19

JAMESBURY 7000 & 9000 SERIES FLANGED BALL VALVES

1	2	3	4	5	6	7	8	9
2	9150	-	31	22	36	XTZ	1	C

1. sign	VALVE SIZE (inch / mm)
INCHES	2", 3", 4", 6", 8", 10"
DN	50, 80, 100, 150, 200, 250

2. sign	VALVE SERIES & STYLE
9150	Full Bore Class 150 2" - 8" (DN 50 - 200)
9180	Full Bore Class 150* 2" - 8" (DN 50 - 200)
9300	Full Bore Class 300 2" - 8" (DN 50 - 200)
9380	Full Bore Class 300* 2" - 6" (DN 50 - 150)
7150	Standard Bore Class 150 8" & 10" (DN200 & 250) only
7180	Standard Bore Class 150* 8" & 10" (DN200 & 250) only
7300	Standard Bore Class 300 8" & 10" (DN200 & 250) only
7380	Standard Bore Class 300* 8" & 10" (DN200 & 250) only
730S	Standard Bore Class 300 8" & 10" (DN200 & 250) only
738S	Standard Bore Class 300* 8" & 10" (DN200 & 250) only

* Metric units on nameplate.

3. sign	CONSTRUCTION / SPECIAL SERVICE
-	Standard (no entry)
C	Chlorine
O	Oxygen
V	High Vacuum
VC	High Vacuum Certified
DT	125 RMS Flange Finish
LA	Standard <i>Emission-Pak</i> w/o Leakoff
LL	Standard <i>Emission-Pak</i> w/ Leakoff
LC	Chlorine <i>Emission-Pak</i> w/o Leakoff
L1	Chlorine <i>Emission-Pak</i> w/ Leakoff

4. sign	END CONNECTION CONSTRUCTION
11	Raised Face, <i>Non-Fire-Tite</i> , Non-Trunnion
31	Raised Face, <i>Fire-Tite</i> , Non-Trunnion

5. sign	BODY MATERIAL*
22	Carbon Steel (WCB)
28	Carbon Steel (LCC)
35	Alloy 20 (CN7M)
36	Stainless Steel (CF8M)
71	Monel (M35-1)

6. sign	BALL AND STEM MATERIAL*	SIZE RANGE
35	Alloy 20	All
36	316 Stainless Steel	All
71	Monel ¹	All
73	Hastelloy ²	All
HB	316 SS, 17-4 PH	All
00	Same as body	All (Carbon steel not available)

Note 1: Monel® is the registered trademark of Special Metals Corporation.

Note 2: Hastelloy® is the registered trademark of Haynes International.

7. sign	SEAT MATERIAL	SIZE RANGE
XTZ	Xtreme®	All
TTT	PTFE	All
BTT	PFA	All
LGG ^{†12}	PEEK	All
UUU ¹	UHMWPE	All
MBT ¹²	Barrier-filled PTFE	2" - 4" (DN 50 - 100)

† Requires 17-4PH Stem

Note 1: *Non-Fire-Tite* only

Note 2: Not a self relieving seat design

8. sign	BOLTS	NUTS
1	ASTM A193 Gr B7	ASTM A194 Gr 2H
2	ASTM A193 Gr B8, B8C, B8M or B8T (Class 2)	ASTM A194 Gr 8B, 8CB, 8MB, 8TB, or 8FB
4	QQ-N-286	
5	ASTM A193 Gr B7M	ASTM A194 Gr 2HM

9. sign	MODEL
C	All Sizes

For options not defined, contact the factory.

TABLE 10A Repair Kit Selector (Standard Valve)

Selecting the right repair kit is as easy as A-B-C-D. Find the valve catalog code from the nameplate (see **Figure 1**). Using the information below build the repair kit number.

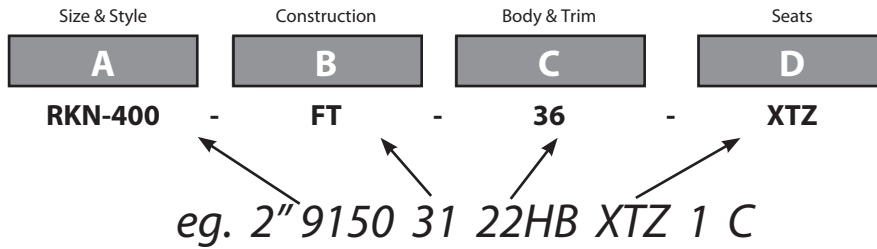

A	Size & Style		
	RKN-400 - 2 9150	RKN-401 - 3 9150	RKN-403 - 4 9150
	RKN-400 - 2 9300	RKN-402 - 3 9300	RKN-404 - 4 9300
		RKN-397 - 6 9150	RKN-397 - 8 7150
B			
	FT - <i>Fire-Tite</i> (31)		
	NFT - <i>non-Fire-Tite</i> (11)		
C	Body & Trim		
	36 - 2236	35 - 2235	71 - 3671
	36 22HB	35 - 3500	71 - 3671
	36 - 3600	71 - 2271	71 - 7100
	36 - 36HB	71 - 3571	73 - 7300
D	Seats		
	XTZ - <i>Xtreme</i>	LGG - PEEK seats	ZTT - TFM seats
	TTT - PTFE seats	UUU - UHWMPE seats	
	BTT - PFA seats	MBT - Barrier seats	

WARNING: If the valve you are selecting a Repair Kit for has a "Special Service" tag, check with your authorized Neles Distributor for help in selecting the correct kit.

TABLE 10B Repair Kit Selector (Emission-Pak Valve)

Selecting the right repair kit is as easy as A-B-C-D. Find the valve catalog code from the nameplate (see **Figure 1**). Using the information below build the repair kit number.

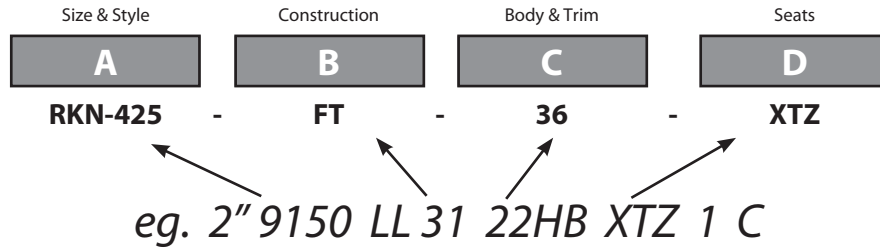

A	Size & Style		
	RKN-425 - 2 9150	RKN-426 - 3 9150	RKN-428 - 4 9150
	RKN-425 - 2 9300	RKN-427 - 3 9300	RKN-429 - 4 9300
		RKN-424 - 6 9150	RKN-424 - 8 7150
B	Construction		
	FT - Fire-Tite (31)		
	NFT - non-Fire-Tite (11)		
C	Body & Trim		
	36 - 2236	35 - 2235	71 - 3671
	36 - 22HB	35 - 3500	71 - 3671
	36 - 3600	71 - 2271	71 - 7100
	36 - 36HB	71 - 3571	73 - 7300
D	Seats		
	XTZ - Xtreme	LGG - PEEK seats	ZTT - TFM seats
	TTT - PTFE seats	UUU - UHWMPE seats	
	BTT - PFA seats	MBT - Barrier seats	

WARNING: If the valve you are selecting a Repair Kit for has a "Special Service" tag, check with your authorized Neles Distributor for help in selecting the correct kit.

Neles

Vanha Porvoontie 229, 01380 Vantaa, Finland.
Tel. +358 10 417 5000.

neles.com