

# NELES

## Quadra-Powr® X Spring Diaphragm Actuators

Installation, Maintenance and  
Operating Instructions

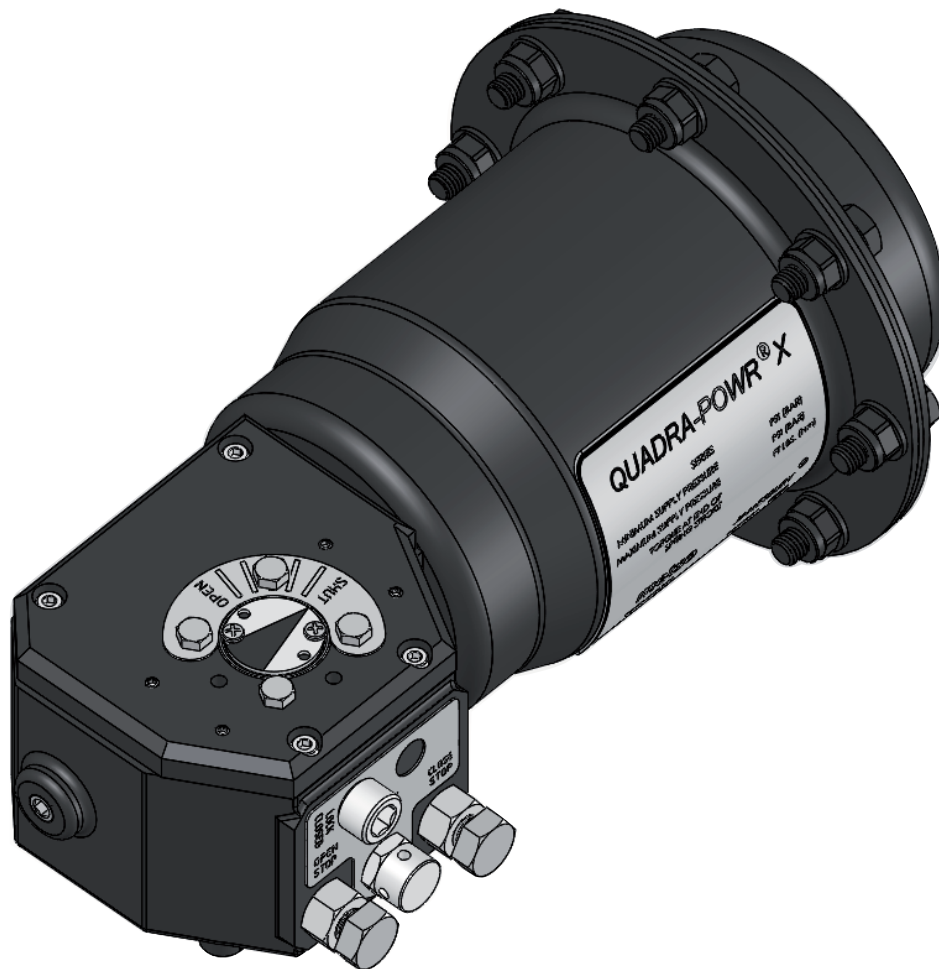

# Table of contents

<b>GENERAL</b>	<b>3</b>
WARNING	3
Handling Quadra-Powr X Actuators	3
<b>INSTALLATION</b>	<b>3</b>
Operation	4
<b>MAINTENANCE</b>	<b>4</b>
Disassembly	4
Assembly	5
<b>PARTS LIST AND BILL OF MATERIALS</b>	<b>6</b>
<b>ACCESSORIES</b>	<b>7</b>
100% Adjustable Stop (AS)	7
Mechanical Lockout (LD)	7
1" NPT Air Inlet (F)	7
Manual Jackscrew Override (MJX)	7
Manual Override Gearbox (SRO)	9
Fusible Plug (LK-3116)	10
<b>REPAIR KITS/ SPARE PARTS</b>	<b>10</b>

## **READ THESE INSTRUCTIONS FIRST!**

These instructions provide information about safe handling and operation of the valve.

If you require additional assistance, please contact the manufacturer or manufacturer's representative.

## **SAVE THESE INSTRUCTIONS!**

Addresses and phone numbers are printed on the back cover.

# 1. GENERAL

This instruction manual contains important information regarding the installation, operation and troubleshooting of *Quadra-Powr X* Spring-Diaphragm Actuators.

This unique spring-diaphragm actuator designed for rotary valves provides safe, smooth and reliable valve actuation at minimal pressures and up to 100 psi (6.9 BAR). As the use of the *Quadra-Powr X* is application specific, many factors should be considered when selecting an actuator for given application. Therefore, some of the situations in which the actuators are used are outside the scope of this manual. If you have any questions concerning the use, application or compatibility of the actuator with the intended service, contact Neles for more information.

Please read these instructions carefully and save them for further reference.

## 1.1 WARNING

LOSS OF AIR PRESSURE MAY CAUSE SPRING-RETURN ACTUATORS TO MOVE TO THEIR 'FAILURE' POSITION.

APPLYING AIR PRESSURE OR CONTROL SIGNAL TO VALVE/ACTUATOR ASSEMBLY MAY CAUSE THE ASSEMBLY TO OPERATE.

BEWARE OF MOVEMENT OF THE VALVE AND ANY LINKAGE BETWEEN IT AND THE ACTUATOR. KEEP HAND, BODY PARTS, TOOLS AND OTHER OBJECTS OUT OF THE WAY OF MOVING PARTS. FAILURE TO DO THIS MAY RESULT IN DAMAGE OR PERSONAL INJURY!

ALWAYS KEEP HANDS AND CLOTHING AWAY FROM THE VALVE PORTS. A CLOSING VALVE ACTS AS A CUTTING DEVICE.

DO NOT TRY TO MANUALLY OPERATE A PRESSURIZED ACTUATOR.

NEVER DISASSEMBLE A PRESSURIZED ACTUATOR! - DISASSEMBLING A PRESSURIZED ACTUATOR WILL LEAD TO UNCONTROLLED RELEASE OF PRESSURE. SHUT OFF SUPPLY PRESSURE AND RELEASE THE PRESSURE FROM THE ACTUATOR BEFORE DISASSEMBLY. FAILURE TO FOLLOW THESE INSTRUCTIONS MAY RESULT IN DAMAGE OR PERSONAL INJURY!

DISASSEMBLY OF A SPRING-RETURN ACTUATOR MAY BE DANGEROUS.

NEVER ATTEMPT TO DISASSEMBLE THE SPRING CARTRIDGE ASSEMBLY OF A SPRING-RETURN ACTUATOR. DISASSEMBLY OF THE SPRING CARTRIDGE ASSEMBLY MAY RESULT IN SERIOUS PERSONAL INJURY! IF MAINTENANCE IS REQUIRED THE ENTIRE SPRING-RETURN ACTUATOR SHOULD BE DIRECTED TO A NELES SERVICE CENTER.

SHUT OFF AND BLEED ALL SUPPLY LINES BEFORE INSTALLATION OR SERVICING THE ACTUATOR.

BEFORE INSTALLING THE VALVE AND ACTUATOR, BE SURE THAT THE INDICATOR POINTER ON TOP OF THE ACTUATOR (AND THE IDENTIFICATION PLATE IN FEMALE ACTUATORS) ARE CORRECTLY INDICATING THE VALVE POSITION. FAILURE TO ASSEMBLE THESE PRODUCTS TO INDICATE CORRECT VALVE POSITION COULD RESULT IN DAMAGE OR PERSONAL INJURY!

THE ACTUATOR MUST BE SIZED ACCURATELY FOR PROPER OPERATION. REFER TO INFORMATION ON THE ACTUATOR END OF STROKE TORQUES AND THE APPROPRIATE VALVE BULLETIN FOR OPERATING TORQUES.

WHEN SERVICING A VALVE ACTUATOR ASSEMBLY, THE BEST PRACTICE IS TO REMOVE THE ENTIRE ASSEMBLY FROM SERVICE. IF THE ACTUATOR IS REMOVED FROM THE VALVE, IT SHOULD BE REMOUNTED ON THAT SAME VALVE AFTER SERVICING IS COMPLETED. THE ACTUATOR MUST BE READJUSTED FOR PROPER "OPEN" AND "CLOSE" POSITION EACH TIME IT IS REMOUNTED.

DO NOT USE VDI/VDE MOUNTING HOLES TO LIFT AN ACTUATOR. OPERATING AN ACTUATOR ABOVE ITS TEMPERATURE LIMITS MAY DAMAGE INTERNAL AND EXTERNAL COMPONENTS AND MAY RESULT IN PERSONAL INJURY!

OPERATING OVER THE PUBLISHED PRESSURE LIMITS OF THE ACTUATOR MAY RESULT IN DAMAGE OR FAILURE OF THE ACTUATOR HOUSING, AND MAY RESULT IN PERSONAL INJURY!

## 1.2 HANDLING QUADRA-POWR X ACTUATORS

When handling the actuator or valve/actuator assembly, take its weight into account! Approximate actuator weights are shown in **Table 1**. Never lift the actuator or valve/actuator assembly by the actuator positioner, limit switch, their piping, or an NPT air connection. Handling of the actuator should be accomplished using lifting straps as shown in **Figure 1**. Failure to follow these instructions may result in damage or personal injury from falling parts. Obey any local or national requirements.

## 2. INSTALLATION

1. Check to see that the position indicator on the actuator is assembled correctly for the desired failure mode, either spring-to-close or spring-to-open. In the spring-to-close mode, the actuator will cycle clockwise to close upon loss of pressure. In the spring-to-open mode, the actuator will cycle counterclockwise to open upon loss of pressure.
2. If the actuator is not set up in the configuration desired, remove the four hex head screws (33), indicator plate (12), indicator pointer (24), and remount them on the opposite mounting surface. In the female actuators, the fastener identification plate shows the failure mode of the actuator.

Table 1.

Handling <i>Quadra-Powr X</i> Actuators	
Actuator Series	Approx. Weight kg (Lb.)
QPX1	12 (26)
QPX2	18 (39)
QPX3	30 (65)
QPX4	48 (105)
QPX5	94 (205)

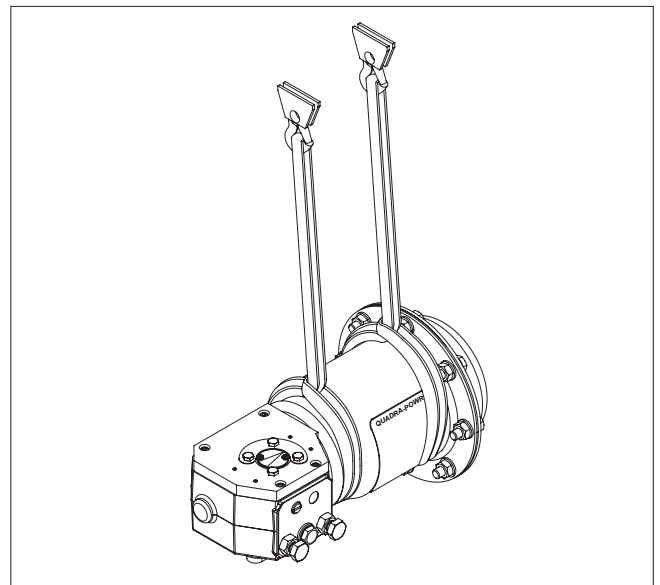

Figure 2.

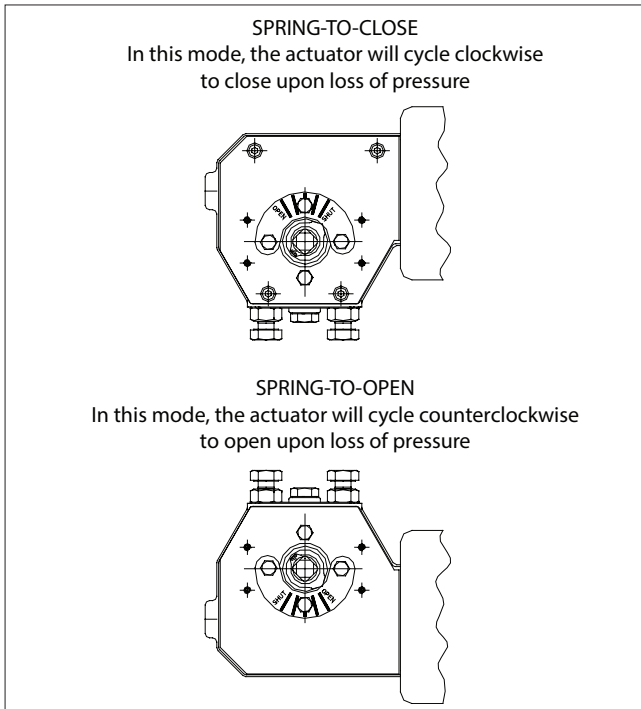

Figure 2.

3. Mount the actuator to the valve following the directions in the AMI (Actuator Mounting Instructions) or valve IMO.
4. Connect a regulated air supply to the 3/8" NPT fitting in the diaphragm casing (15). **CAUTION:** The maximum operating pressure is 100 psi (6.9 BAR).
5. Adjust the stop screws (19) by releasing the jam nut (23) and turning. Stops can only be adjusted when driver arm (3) is off the stop screws being adjusted. (Maximum rotation adjustment  $\pm 5^\circ$ .) Be sure to retighten jam nut (23).

## 2.1 OPERATION

The operating pressure, output torque and drive type is determined by the actuator designation. Maximum operating pressure is 100 psi (6.9 BAR). (See Table 2)

Actuator designation example: QPX4C/K40 is a series QPX4 spring diaphragm actuator that has a 60 psi (4.1 BAR) spring, an end of air pressure stroke output torque of 200 FT•LBS (272 N•m) and uses a 40 mm female key to drive the valve.

Before operating make sure all tapped holes in the body which are not being used are resealed with fasteners.

## 3. MAINTENANCE

Although Neles *Jamesbury* actuators are designed to work under severe conditions, proper preventative maintenance can significantly help to prevent unplanned downtime and in real terms reduce the total cost of ownership. Neles recommends inspecting actuators at least every five (5) years. The inspection and maintenance frequency depends on the actual application and process condition.

Before working on a *Quadra-Powr X* actuator, note that all fasteners except socket head shoulder screw (8) and hex head cap screw (88, on QPX4 & QPX5) are metric.

Table 2

Actuator Series	Spring Version	Operating Pressure in psi (BAR)	End of Spring Stroke Torque in FT•LBS (N•m)	Drive Type
QPX1	C	60 (4.1)	25 (34)	K15 - 15 mm Keyed M - 9/16" Square
QPX2	A**	20* (1.4)	11 (15)	
	B	40 (2.8)	38 (52)	K20 - 20 mm Keyed M - 9/16" Square
	C	60 (4.1)	57 (77)	
	D	80 (5.5)	74 (100)	
QPX3	A	20* (1.4)	26 (35)	K35 - 35 mm Keyed M - 3/4" Square
	B	40 (2.8)	76 (103)	
	C	60 (4.1)	114 (155)	
	D	80 (5.5)	146 (198)	
QPX4	B	40 (2.8)	153 (207)	K40 - 40 mm Keyed M - 1" Square
	C	60 (4.1)	229 (310)	
	D	80 (5.5)	294 (399)	
QPX5	B	40 (2.8)	305 (414)	K40 - 40 mm Keyed M - 1" Square
	C	60 (4.1)	458 (621)	
	D	80 (5.5)	587 (796)	

\* For Direct Control Application  
 \*\* QPX2A only available with QPX1 drive type options.

Under normal operating conditions the actuator requires only periodic observation to ensure proper adjustment. Standard replacement of "soft" parts in *Quadra-Powr X* actuators consists of items numbered 6, 14, 31, 62 and 64. See **REPAIR KITS/SPARE PARTS** Section.

1. When replacing the diaphragm use caution and be sure the air supply is disconnected. Back off nuts (29) from the hex head screws (27), holding the diaphragm casing and spring housing together until the nuts are flush with the hex head screw ends. Do not remove the nuts completely from the hex head screws. If tension still exists on the hex head screws, then the spring package is not properly contained. Stop disassembly: retighten nuts and return the actuator to the factory. If the spring package proves to be intact remove the nuts (29) and remove the hex head screws (27).
2. Lift off diaphragm casing (15). Remove hex head cap screw (88) and retaining washer (89). Remove diaphragm (14).
3. Inspect the inside of both the diaphragm casing (15) and the spring housing (32) for any rough spots or foreign matter which may cause abrasion to the diaphragm.
4. Place the new diaphragm (14) on the diaphragm retainer (10). Do not pinch or stretch the diaphragm. Attach with washer (89) and cap screw (88). Tighten to value in (Table 3) keeping spring housing (32) holes aligned with diaphragm (14) holes. Place the diaphragm casing (15) on the spring housing (32) and line up all the holes.
5. Insert hex head screws (27) in all holes. Do not force the hex head screws through the diaphragm. Install nuts (29) on screws and tighten uniformly using the standard practice of tightening diametrically opposite bolts in sequence with the torque requirements from (Table 3).

## 3.1 DISASSEMBLY

When disassembly of the actuator is required for maintenance, remove the actuator to a clean well lit area. Handling of the actuator is accomplished by using lifting straps. See **Section 1.2**.

**CAUTION:** Disconnect any pneumatic or electrical supplies, and vent any air pressure in the actuator before attempting any disassembly.

Obtain the following tools: two (2) M10 wrenches, preferably one being a ratchet, one (1) hex (Allen) wrench, 3 mm for QPX1, 5 mm for QPX2, 3 and 4, 6 mm for QPX5, one (1) screwdriver, one (1) plastic faced mallet.

1. Remove the cover (5) by removing six (four on QPX1) socket cap screws (21). If the cover cannot be removed, tap it with a plastic hammer to break the adhesion of the paint between the body and cover joint.
2. Use air pressure to remove spring preload by partially stroking the actuator. If the diaphragm (14) is ruptured, replace as instructed in the previous section.
3. To remove the socket shoulder screw (8) (or socket cap screw in QPX1) that holds the clevis (7) to the driver arm (3), first apply some heat to the lower arm to loosen the Loctite® on threads of the socket shoulder screw. **CAUTION:** DO NOT place fingers or hands inside Driver Housing when disconnecting Clevis from Driver Arm.
4. Slowly increase air pressure until the driver arm (3) moves slightly off the stop screw (19). Remove the socket shoulder screw (8).
5. Slowly relieve the air pressure in the actuator. The clevis (7) should be set against the spring retainer (30), and positioned symmetrically about the slot in the spring housing.
6. Shut off and bleed the air pressure to zero. Disconnect the air lines.
7. Remove the hex head screws (27) and hex nuts (29) holding the diaphragm casing and spring housing together. **CAUTION:** DO NOT remove diaphragm casing hex head cap screws (27) and nuts (29) or diaphragm casing while the actuator is pressurized.
8. Lift off diaphragm casing (15), remove hex head cap screw (88), washer (89) and diaphragm (14). Inspect the diaphragm for signs of wear, rupture or mechanical damage.
9. Inspect the inside of both the diaphragm casing and spring housing, as well as the outside of the diaphragm retainer for any rough spots or foreign matter which may cause abrasion of the diaphragm.
10. Lift the entire spring cartridge out of the unit.

**WARNING:**

DISASSEMBLY OF THE SPRING PACKAGE SHOULD NOT BE ATTEMPTED. SPECIAL EQUIPMENT IS REQUIRED. DISASSEMBLY OF THE SPRING PACKAGE MAY RESULT IN SERIOUS PERSONAL INJURY. IF MAINTENANCE IS REQUIRED SHIP THE ENTIRE ACTUATOR TO NELES.

It is usually not necessary to remove the spring housing (32) from the body (1). However, if removal is required, heat must be used to loosen the Loctite®. When reassembling, the information in (Table 3), torque and Loctite® recommendations must be met. All fasteners should use Loctite® 271 on the threads. Inspect and clean all components.

Good practice dictates that all bearings should be removed and replaced. See section 5 of this IMO for the proper actuator series repair kit number.

### 3.2 ASSEMBLY

To aid assembly, spread light oil or grease on the outside diameter of the new bearings.

1. Press driver arm bearings (6) into the body (1) and covers (5). This is best done in an arbor press, but a vise could be used if care is taken not to damage the bearing. Driver arm bearings are

to be pressed in until they are flush or 0.015 in. (0.38 mm) below the body counterbore or the inside cover surface. Press clevis bearings (62) into the clevis (7).

2. Apply lubricant, MOLYKOTE® GN grease on the barrel of shoulder screw (8) prior to assembly. Also, apply MOLYKOTE® GN grease to driver arm bearings (6).
3. Place the thrust bearing (31) into the counterbore in the body of QPX1-QPX5 actuators. Slide the other thrust bearing onto the trunnion of the driver arm (3). Place the driver in the body.
4. Spring housing (32), diaphragm retainer (10) and springs shall be lubricated with Kendall L-427 Super Blu® or Mobilgrease™ XHP 222. Lower the spring cartridge into the spring housing (32). Make sure that the spring package is not resting on the hex head cap screws (38) which hold the spring housing and body together. If bearing (64) has separated from diaphragm retainer (10), hold in place while lowering spring cartridge into housing.
5. Place the new diaphragm (14) on the diaphragm plate. Attach diaphragm (14) to diaphragm retainer (10) using washer (89) and hex head cap screw (88). Torque to the value specified in (Table 3).
6. Insert the hex head bolt (27) in all holes. Do not force the bolts through the diaphragm. Install nuts (29) and tighten uni-formly using the standard practice of tightening diametrically opposed bolts (criss cross pattern) in sequence. Follow (Table 3) for tightening torques.
7. Connect a regulated air supply to the pressure port and slowly increase the air pressure until the holes in the clevis and driver arm are aligned. Turn clevis a few degrees, if required, to align holes.
8. Apply Loctite® 271 on the threads of the shoulder screw. Insert it through the driver arm and clevis. Tighten per (Table 3).
9. Slowly release air pressure. Assemble cover by using the socket head screws (21). Apply tightening torque per (Table 3).
10. Install the indicator pointer (24) if this was previously disassembled. In female actuators make certain that the indicator points to the inscribed line in the driver arm. In male actuators, hold the indicator pointer in place with a retaining ring (9). **NOTE:** Refer to Installation instructions for spring-to-close or spring-to-open configuration.

Table 3

Torque Requirements					
Required Tightening Torques In FT•LBS (N•m) For Various Fasteners					
	QPX1	QPX2	QPX3	QPX4	QPX5
Nuts for Hex Head Screws through Diaphragm Casing (29)	24 (32)	24 (32)	24 (32)	24 (32)	24 (32)
Socket Head Cover Screws (21)	4 (5)	6 (8)	6 (8)	6 (8)	15 (20)
Socket Head Shoulder Screw (8)	35 (48)	55 (75)	132 (179)	132 (179)	132 (179)
Nuts on Actuator Rod (74)	55 (74)	55 (75)	88 (119)	132 (176)	176 (239)
Hex Head Screws between Body and Spring Housing (38)	5 (7)	18 (24)	30 (40)	30 (40)	55 (75)
Hex Head Cap Screws for Attaching Diaphragm to Diaphragm Retainer (88)	19 IN•LBS (1)	19 IN•LBS (1)	27 IN•LBS (2)	10 FT•LBS (14)	17 FT•LBS (23)

### 3.3 PARTS LIST AND BILL OF MATERIALS

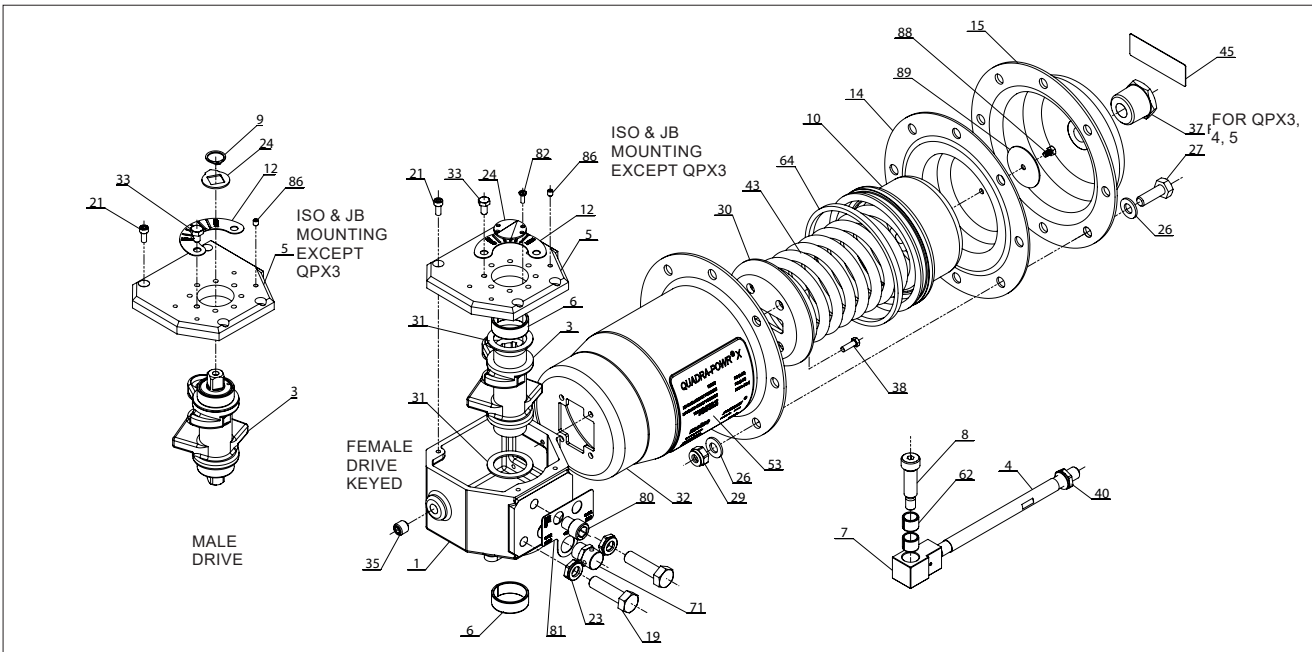

**Bills Of Materials And Parts**

ITEM NO.	PART DESCRIPTION	QPX1	QPX2	QPX3	QPX4	QPX5
1	Driver housing	1	1	1	1	1
3	Driver arm	1	1	1	1	1
4	Actuator rod	1	1	1	1	1
5	Cover	1	1	1	1	1
6 y	Driver arm bearing	2	2	2	2	2
7	Clevis	1	1	1	1	1
8	Shoulder screw	1	1	1	1	1
9	Retaining ring*	1	1	1	1	1
10	Diaphragm retainer	1	1	1	1	1
12	Indicator plate	1	1	1	1	1
14 x, y	Diaphragm with centering hole	1	1	1	1	1
15	Diaphragm casing	1	1	1	1	1
19	Hex head cap screw	2	2	2	2	2
21	Socket head cap screw	4	4 or 6	6	6	6
23	Hex Jam Nut	2	2	2	2	2
24	Indicator pointer	1	1	1	1	1
26	Washer	16	24	24	32	48
27	Hex head cap screw	8	12	12	16	24
29	Nylon insert lock nut	8	12	12	16	24
30	Spring retainer	1	1	1	1	1
31 y	Thrust bearing	2	2	2	2	2
32	Spring housing	1	1	1	1	1
33	Hex head cap screw	4	4	4	4	4
35	Set screw	1	1	1	1	1
37	NTP adapter	N/A	N/A	1	1	1
38	Hex head cap screw	4	4	6	10	10
40	Hex Jam Nut	1	1	1	1	1
43	Compression Spring	1	1	1	1	1
45	Attention plate	1	1	1	1	1
53	Identification tag	1	1	1	1	1
62 y	Clevis bearing	2	2	2	2	2
64 x, y	Bearing, diaphragm retainer	1	1	1	1	1
71	Breather	1	1	1	1	1
80	Hex Head Cap Screw	1	1	1	1	1
81	Name plate	1	1	1	1	1
82	Screw **	2	2	2	2	2
86	Socket set screw**	8	8	8	8	8
88	Hex head cap screw	1	1	1	1	1
89	Diaphragm washer	1	1	1	1	1

\* MALE ACTUATORS ONLY.

\*\* FEMALE ACTUATORS ONLY.

x = Included with Diaphragm Service Kit

y = Included with Complete Service Kit

## 4. ACCESSORIES

### 4.1 100% ADJUSTABLE STOP (AS)

The standard *Quadra-Powr* can be configured in the field for a 100% adjustable stop. Remove the set screw plug (35) with an allen wrench. Thread in the adjustable stop screw enough to reach the desired stop position and allow room for the lock nut. Screw on the lock nut for the adjustable stop and tighten to secure it in place.

### 4.2 MECHANICAL LOCKOUT (LD)

The standard *Quadra-Powr* can be configured in the field for a locking device to lock the actuator in its failsafe position. Installation of the locking device does not require adjustment of the standard open/close limit screws.

#### Installation (see Figure 3)

1. Before attempting to assemble lockout devices, make certain that the actuator is not pressurized.
2. Remove the plug (80) using an allen wrench.
3. Remove the lower jam nut from the locking stud.
4. Insert the locking stud through the hole in the locking plate. Thread the locking stud into the lockout hole and tighten securely. Tighten the upper jam nut to secure the locking plate. Pivot the locking cover down until the hole in the cover lines up with the hole in the end of the locking plate.
5. Secure the locking device with a padlock. A padlock with 1/4" – 5/16" (6.35 – 7.9mm) diameter shackle is recommended.

#### Removal and storage (see Figure 4)

1. Remove the padlock and swing the cover out of the way.
2. Loosen (do not remove) the upper jam nut and then remove the locking stud.
3. With the locking stud still inserted through the large hole in the locking plate, thread the lower jam nut onto the bottom of the stud. This will secure the stud and nuts for storage.
4. Re-insert the plug (item 80) into the locking hole. The wire tie can be secured to the plug for storage of the locking device.

### 4.3 1" NPT AIR INLET (F)

**NOTE:** Applicable only to QPX size 3 – 5.

Remove the 3/8" Reducing bushing (Item 37) to access the 1" NPT port.

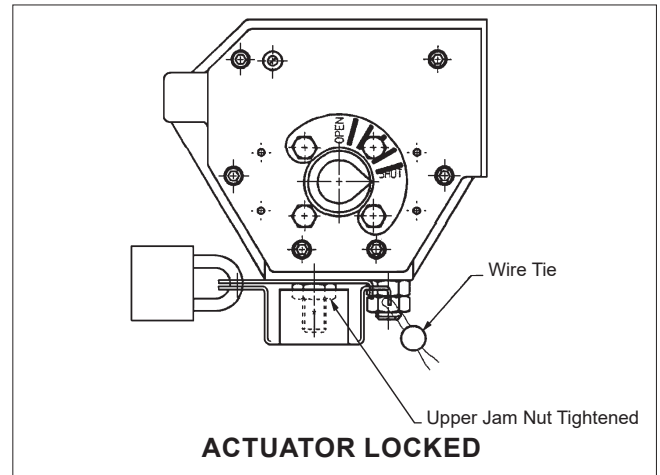

Figure 3.

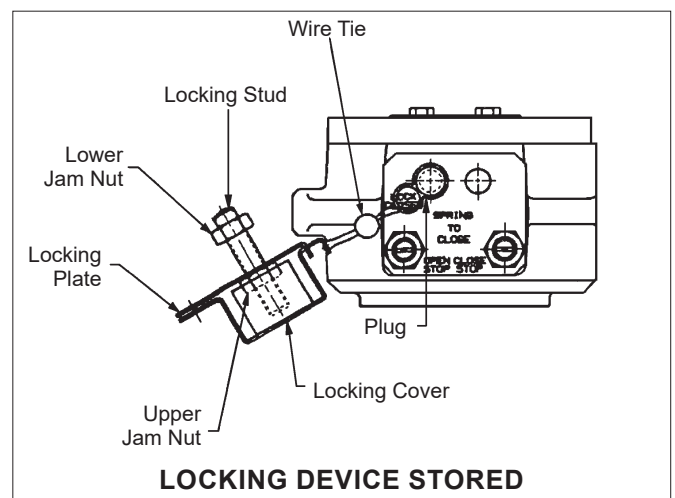

Figure 4.

### 4.4 MANUAL JACKSCREW OVERRIDE (MJX)



Figure 5.

The MJX is intended to move the valve upon failure of the actuator, supply air, or electrical system. When the handwheel of the manual jackscrew is turned clockwise, force is exerted on the diaphragm retainer, compressing the actuator spring and operating the valve in the direction of the air stroke.

## Installation

### WARNING:

SHUTOFF AND BLEED THE AIR SUPPLY LINE BEFORE INSTALLATION OR SERVICING. IF THERE IS STILL SPRING PRESSURE ON THE OVERRIDE SHAFT WHEN IT IS BACKED OUT, ALL THE WAY COUNTER CLOCKWISE, DO NOT DISASSEMBLE THE DIAPHRAGM CASING SCREWS.

1. On the actuator, remove the diaphragm casing from the spring housing by removing the lock nuts (13), flat washers (12), and hex head cap screws (11).
2. Once the diaphragm casing is removed, inspect the diaphragm for signs of damage and replace as needed.
3. On the MJX, turn the acme screw (2) counter clockwise until the o-ring (6) and o-ring carrier (3) are seated inside the MJX housing (1).
4. Install the MJX housing sub-assembly (1) in place of the diaphragm casing using the lock nuts (13), flat washers (12) and hex head cap screws (11) that were supplied with the MJX housing sub-assembly (1). The lock nuts (13) and hex head cap screws (11) must be tightened to a torque of 22..25 ft-lbs (30..34 Nm).

## Operation

### WARNING:

THE JACKSCREW IS NOT TO BE USED AS AN ADJUSTABLE OPEN STOP. THE JACKSCREW HANDWHEEL MUST BE FULLY RETRACTED DURING NORMAL OPERATION.

1. The jackscrew is operated by turning the handwheel clockwise. Depending on the jackscrew model, it can take between 17 and 35 turns to achieve full rotation. See the MJX Exploded View for details.
2. Stop turning the handle once the desired valve position is achieved.
3. When the cause of the malfunction is solved, turn the handwheel back to the actuator failsafe position. The actuator can now control the valve.

### Maintenance

1. All units are shipped fully greased and require only periodic inspection and greasing. If needed, use grease fitting (14) to add Molykote type grease until the grease cavity is full.
2. The MJX housing sub-assembly should not be fully disassembled. Some parts can be replaced if damaged, such as thrust bearing (7), pressure pad (4), hex head cap screw (8) and o-ring (6).

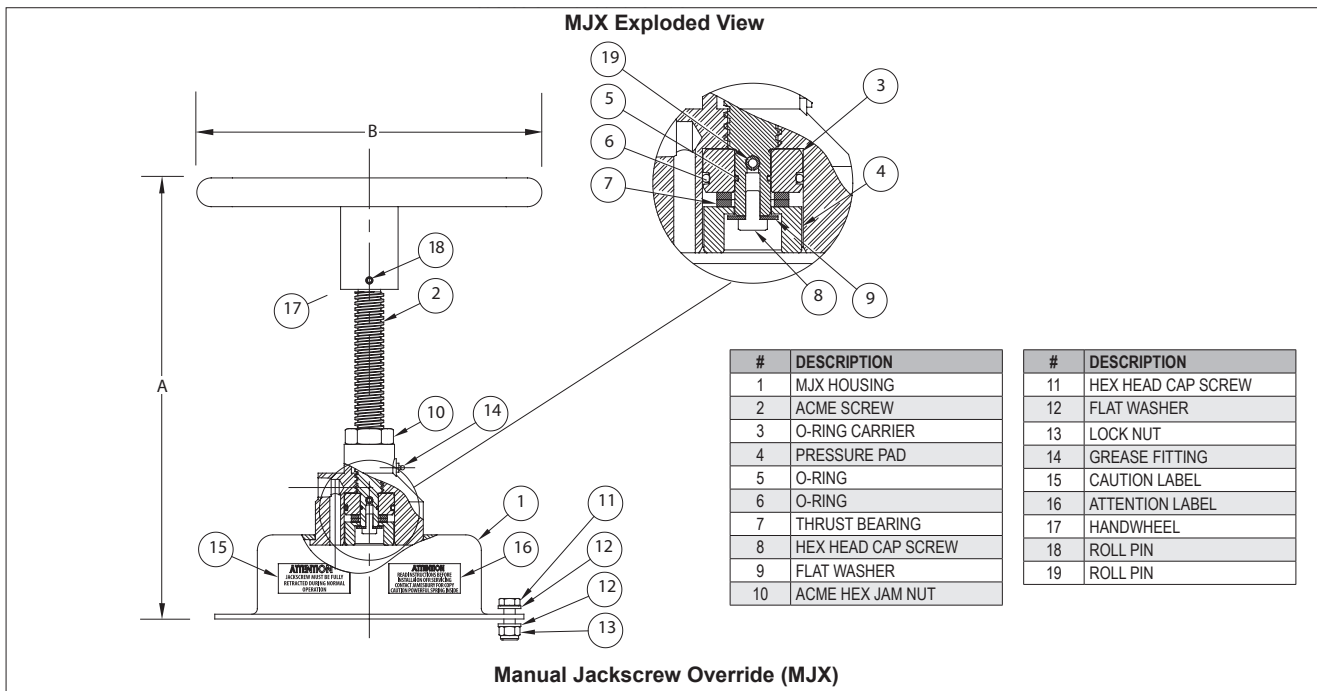

Figure 6.

Jackscrew specification								
Model	For actuator series	Max. input torque*		Number of turns to fully compress spring	Approximate dimensions			
		N-m	ft-lb		A		B	
					mm	in	mm	in
MJX-1	QPX-1	11	8	17	358.9	14.13	200	7.87
MJX-2	QPX-2	22	16	18	409.4	16.12	300	11.81
MJX-3	QPX-3	49	36	21	457.5	18.01	400	15.75
MJX-4	QPX-4	56	41	25	532.4	20.96	500	19.69
MJX-5	QPX-5	89	66	35	603.8	23.77	600	23.62

\*Based on typical valve with 80-psi (5.5) bar actuator spring.

## 4.5 MANUAL OVERRIDE GEARBOX (SRO)

The SRO is intended to move the valve upon failure of the actuator, supply air, or electrical system. **NOTE:** The following instructions reference a fail closed (clockwise to close) installation, but a fail open installation is also possible. The SRO can only be mounted to a QPX\_/M male drive.

### Installation

1. It is recommended to mount the handwheel on the input shaft prior to assembling the gearbox to the valve.
2. Verify that the flanges on the gearbox and valve align. Also verify that the valve stem and the bore of the gearbox driveshaft match.
3. Make sure the valve is in the fully closed position.
4. Make sure that the gearbox is in the fully closed position (as standard from the factory). This is achieved by turning the handwheel clockwise.
5. Screw the stud bolts into the bottom flange of the gearbox prior to mounting the gearbox on top of the valve.
6. **NOTE:** use of a gasket/sealant on the flanges between the valve/ gearbox and between the gearbox/actuator is recommended.
7. Insert the drive shaft of the valve into the bottom side onto the gearbox.
8. Ensure the driveshaft can make a free quarter turn clockwise (seen from the bottom side) from its end position. The gearbox can then open the valve in case of actuator or supply air failure.
9. Mount the gearbox perpendicular to the valve and secure the fasteners.
10. Mount the actuator on top of the gearbox.

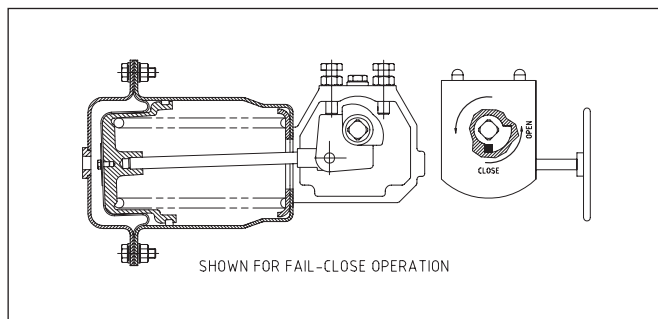

Figure 7.

### Stop screw adjustment

1. Remove the air from the actuator and ensure the valve/ actuator/gear are in the fully closed position.
2. With the actuator and gear mounted, backout both stop screws on the gear by 3-4 turns.
3. Using the actuator to cycle the valve, set the actuator stops for both open and close (see **section 2** of this IMO for instructions).
4. Open Stop: Turn the gear handwheel counter clockwise until it stops. Turn-in the gear open stop screw (**Figure 8**) until it stops and then tighten the lock nut.
5. Close Stop: Turn the gear handwheel clockwise until it stops. Turn-in the gear close stop screw (**Figure 8**) until it stops and then tighten the lock nut.
6. For a fail open actuator, reverse the above procedure.

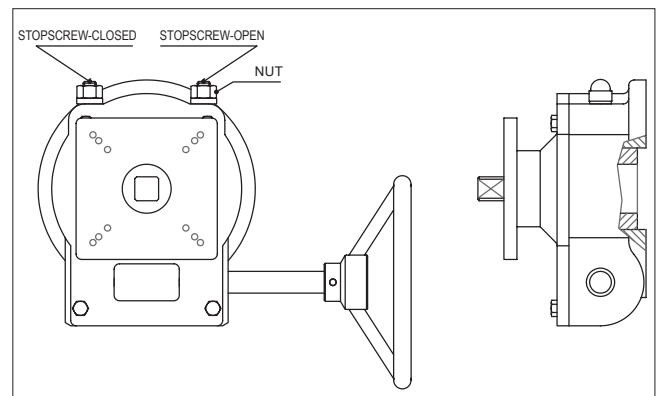

Figure 8.

### Operation

1. Vent the supply air from the pneumatic actuator.
2. The gearbox is operated by turning the handwheel. Depending on the gearbox model, it can take between 8 and 13 turns to achieve full rotation.
3. The gearbox is self-braking so simply stop turning the handle once the desired valve position is achieved.
4. When the cause of the malfunction is solved, turn the handwheel back to the actuator failsafe position. The actuator can now control the valve.

## 4.6 FUSIBLE PLUG (LK-3116)

The fusible plug melts during a fire or excessive environmental temperature when the temperature reaches an approximate level of 165°F. This releases the air from the diaphragm case and rotates the valve to its fail-safe position.

**NOTE:** If needed, LK-3192 has a higher melting point of 212°F.

### Installation

1. Using thread sealant, attach the fusible plug (3) and pipe nipple (1) into the street tee as shown in **Figure 9**.
2. Insert this assembly into the plug guard (4) and secure using the screw (5), lock washer (6), and hex nut (7).
3. Using thread sealant, attach the completed fusible plug assembly to the 3/8" NPT port on the QPX diaphragm casing. The tubing from the solenoid or positioner will attach to the other end of the pipe nipple.

## 5. REPAIR KITS/SPARE PARTS

SERVICE KITS		
Model	Complete	Diaphragm
QPX1	RKQ-68	RKQ-75
QPX2	RKQ-70	RKQ-76
QPX3	RKQ-71	RKQ-77
QPX4	RKQ-72	RKQ-78
QPX5	RKQ-73	RKQ-79

For further information on spare parts and service or assistance visit our web-site at [www.neles.com/products](http://www.neles.com/products)

### Fusible plug Exploded View

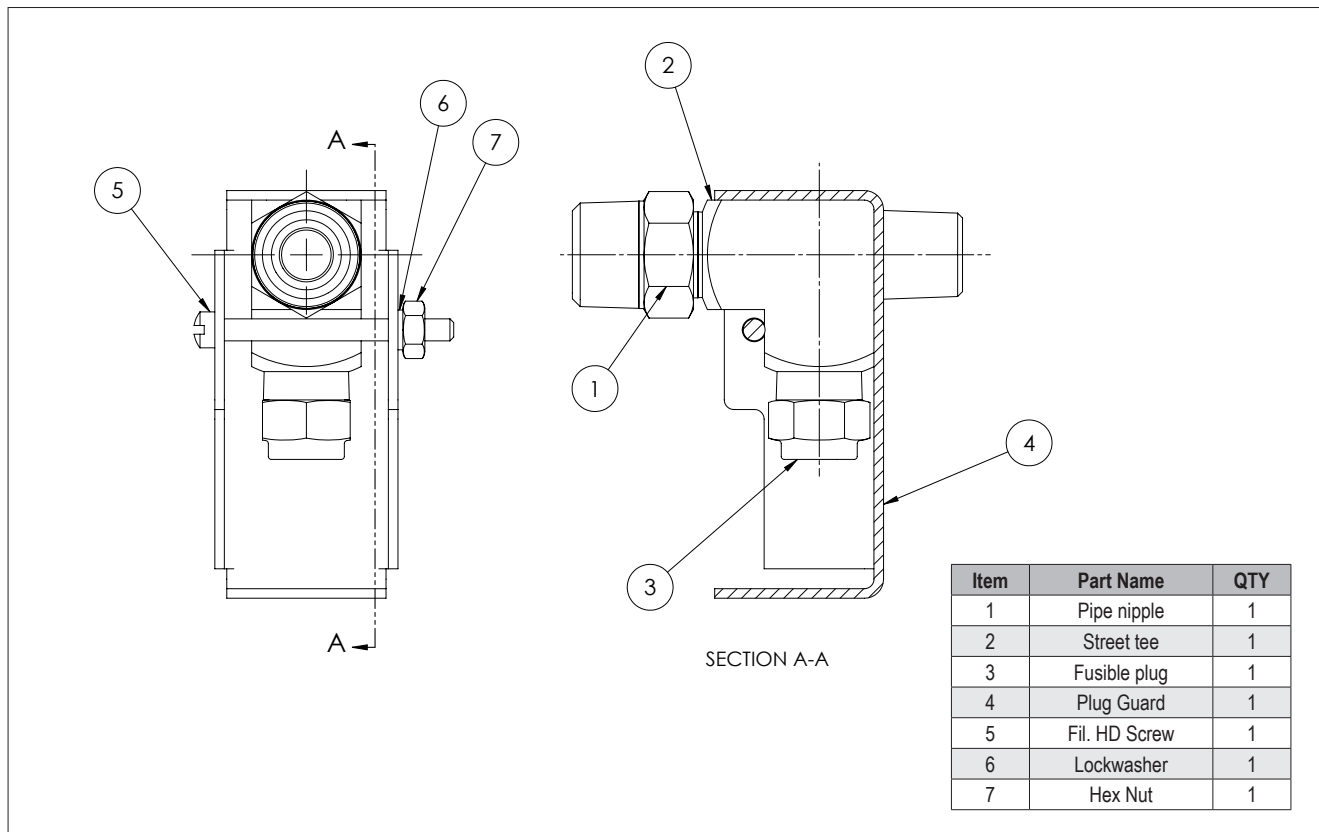

Figure 9.

**WARNING:**

As the use of the actuator is application specific, a number of factors should be taken into account when selecting a valve for a given application. Therefore, some of the situations in which the

valves are used are outside the scope of this manual. If you have any questions concerning the use, application or compatibility of the valve with the intended service, contact Neles for more information.

**HOW TO ORDER****PNEUMATIC, SPRING-DIAPHRAGM ACTUATOR, Series QPX**

1.	2.	3.	/	4.	5.	6.
QPX	1	C		M	AS	C

1. sign	2. sign	3. sign	4. sign		5. sign	6. sign
Actuator Series	Size	Spring Option	Keyed Female Drive	Male Square Drive	Options	Model version
QPX	1	C	K15 (15 mm)	M (Male Square)	- No sign, standard version AS 100% Adjustable stop MJX Manual Jackscrew Override SO Fail Open F 1" NPT Air Inlet (2. sign "3-5" only)	C (Model C)
	2	A				
		B				
		C				
		D				
	3	A	K35 (35 mm)			
		B				
		C				
		D				
	4	B	K40 (40 mm)			
		C				
		D				
		B				
	5	C				
		D				

3. sign	Spring Option Details
A	1.3 bar / 20 psi
B	2.8 bar / 40 psi
C	4.1 bar / 60 psi (standard)
D	5.5 bar / 80 psi

**ACCESSORIES**

Field Mountable Accessories		QPX Size				
		1	2	3	4	5
100% Adjustable Stop Kit	Code	AS-1		AS-3	AS-4	AS-5
	P/N	MA0234139		MA0234140	MA0234141	MA0234142
Mechanical Lockout Kit	Code	LD-60		LD-61	LD-62	LD-63
	P/N	MA0026407		MA0026408	MA0026409	MA0026410
Manual Jackscrew Override Kit	Code	MJX-1	MJX-2	MJX-3	MJX-4	MJX-5
	P/N	MA0026451	MA0026452	MA0026453	MA0026454	MA0026455
Manual Override Gearbox (QPX_/M only)	Code	SRO-1	SRO-2	SRO-3	SRO-4	SRO-5
	P/N	MA0043214	MA0043215	MA0043216	MA0043217	MA0043218
Fusible Plug	Code	LK-3116				
	P/N	MA0044535				

# Neles

Vanha Porvoontie 229, 01380 Vantaa, Finland.  
Tel. +358 10 417 5000.

**neles.com**

IMO-215 EN - 8/2020

Subject to change without prior notice. Neles, Jamesbury and Easyflow by Neles and Wafer-Sphere, and certain other trademarks, are either registered trademarks or trademarks of Neles Corporation or its subsidiaries or affiliates in the United States and/or in other countries. For more information [www.neles.com/trademarks](http://www.neles.com/trademarks)

Reinventing  
reliability