

NELES

Standard bore flanged ball valves series 7000 railroad

Series 7150RR, 7300RR & 730SRR

3" – 6" (DN 50 – 150) Class 150

3" (DN 50) Class 300

Installation, maintenance and
operating instructions

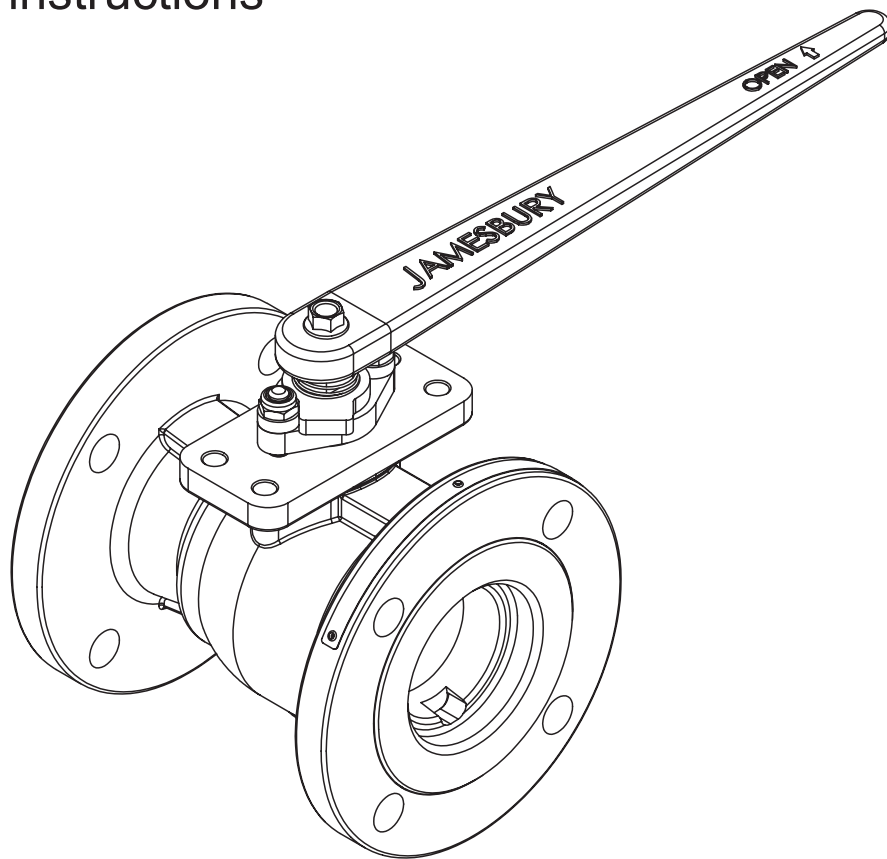

Table of Contents

1. GENERAL	3
1.1 Scope of the Manual	3
1.2 Valve Markings	3
1.3 Safety Precautions	3
2. TRANSPORTATION AND STORAGE	4
3. INSTALLATION	4
3.1 General	4
3.2 Handles	4
3.3 Installing on Tank Car	4
3.4 Commissioning	4
3.5 Steam Jacket Connections	4
4. MAINTENANCE	4
4.1 General	4
4.2 Disassembly	5
4.3 Checking Parts	5
4.4 Assembly	6
4.5 Pressure Testing the Valve	7
5. REPAIR KITS	7
6. SERVICE/SPARE PARTS	7
7. EXPLODED VIEW - VALVE	8
8. EXPLODED VIEW - INSERT FIELD WRENCH	9
9. HOW TO ORDER 7000 SERIES RAILROAD VALVES	11

READ THESE INSTRUCTIONS FIRST!

These instructions provide information about safe handling and operation of the valve.

If you require additional assistance, please contact the manufacturer or manufacturer's representative.

SAVE THESE INSTRUCTIONS!

Addresses and phone numbers are printed on the back cover.

1. GENERAL

1.1 Scope of the Manual

This instruction manual contains important information regarding the installation, maintenance and troubleshooting of Jamesbury® 3" – 6" (DN 50 – 150) Series 7150RR and 3" (DN 50) Series 7300RR and 730SRR Standard Bore Flanged Ball Valves for railroad service. Please read the instructions carefully and save them for future reference.

WARNING:

AS THE USE OF THE VALVE IS APPLICATION SPECIFIC, A NUMBER OF FACTORS SHOULD BE TAKEN INTO ACCOUNT WHEN SELECTING A VALVE FOR A GIVEN APPLICATION. THEREFORE, SOME OF THE SITUATIONS IN WHICH THE VALVES ARE USED ARE OUTSIDE THE SCOPE OF THIS MANUAL.

IF YOU HAVE ANY QUESTIONS CONCERNING THE USE, APPLICATION OR COMPATIBILITY OF THE VALVE WITH THE INTENDED SERVICE, CONTACT NELES FOR MORE INFORMATION.

1.2 Valve Markings

The valve has an identifications plate attached to the pipeline flange (See **Figure 1**).

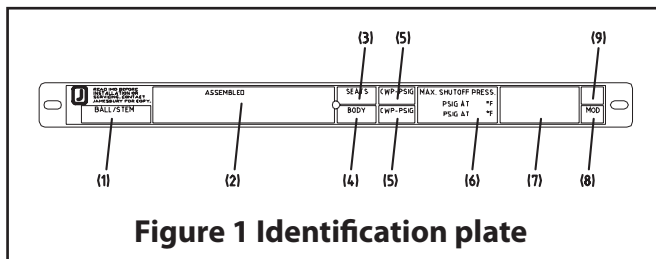

Figure 1 Identification plate

Identification plate markings:

1. Ball/Stem material
2. Valve catalog code
3. Seat Material
4. Body Material
5. Maximum operating pressure
6. Maximum/minimum shut-off pressure/temperature
7. Approvals/Special Service marking
8. Model
9. Assembly date

1.3 Safety Precautions

WARNING:

DO NOT EXCEED THE VALVE PERFORMANCE LIMITATIONS!

EXCEEDING THE PRESSURE OR TEMPERATURE LIMITATIONS MARKED ON THE VALVE IDENTIFICATION PLATE MAY CAUSE DAMAGE AND LEAD TO UNCONTROLLED PRESSURE RELEASE. DAMAGE OR PERSONAL INJURY MAY RESULT.

WARNING:

SEAT AND BODY RATINGS!

THE PRACTICAL AND SAFE USE OF THIS PRODUCT IS DETERMINED BY BOTH THE SEAT AND BODY RATINGS. READ THE IDENTIFICATION PLATE AND CHECK BOTH RATINGS. THIS PRODUCT IS AVAILABLE WITH A VARIETY OF SEAT MATERIALS. SOME OF THE SEAT MATERIALS HAVE PRESSURE RATINGS THAT ARE LESS THAN THE BODY RATINGS. ALL OF THE BODY AND SEAT RATINGS ARE DEPENDENT ON VALVE TYPE AND SIZE, SEAT MATERIAL, AND TEMPERATURE. DO NOT EXCEED THESE RATINGS!

WARNING:

BEWARE OF BALL MOVEMENT!

KEEP HANDS, OTHER PARTS OF THE BODY, TOOLS AND OTHER OBJECTS OUT OF THE OPEN FLOW PORT. LEAVE NO FOREIGN OBJECTS INSIDE THE TANK CAR. WHEN THE VALVE IS ACTUATED, THE BALL FUNCTIONS AS A CUTTING DEVICE. DISCONNECT ANY PNEUMATIC SUPPLY LINES, ANY ELECTRICAL POWER SOURCES AND MAKE SURE SPRINGS IN SPRING-RETURN ACTUATORS ARE IN THE FULL EXTENDED/RELAXED STATE BEFORE PERFORMING ANY VALVE MAINTENANCE. FAILURE TO DO THIS MAY RESULT IN DAMAGE OR PERSONAL INJURY!

WARNING:

WHEN HANDLING THE VALVE OR VALVE/ACTUATOR ASSEMBLY, TAKE ITS WEIGHT INTO ACCOUNT!

NEVER LIFT THE VALVE OR VALVE/ACTUATOR ASSEMBLY BY THE ACTUATOR, POSITIONED, LIMIT SWITCH OR THE PIPING. PLACE THE LIFTING DEVICES SECURELY AROUND THE VALVE BODY. FAILURE TO FOLLOW THESE INSTRUCTIONS MAY RESULT IN DAMAGE OR PERSONAL INJURY FROM FALLING PARTS.

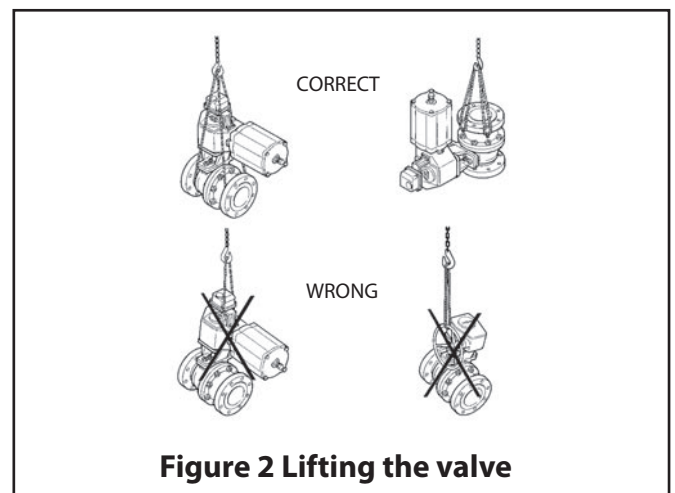

Figure 2 Lifting the valve

2. TRANSPORTATION AND STORAGE

Check the valve and the accompanying devices for any damage that may have occurred during transport.

Store the valve carefully. Storage indoors in a dry place is recommended.

Do not remove the flow port protectors until installing the valve.

Move the valve to its intended locations just before installation.

The valve is usually delivered in the open position.

If the valve(s) will be stored for a long period, follow the recommendations in IMO-S1 to maintain valve's integrity.

3. INSTALLATION

3.1 General

Remove the flow port protectors and check that the valve is clean inside. Clean valve if necessary.

Flush the tankcar carefully before installing the valve. Foreign objects, such as sand or pieces of welding electrodes, will damage the ball and seats.

3.2 Handles

If the valve handle (31) has to be removed for any reason, the handle must be remounted properly. (See **Figure 8**)

WARNING:

FAILURE TO PROPERLY MOUNT THE HANDLE MAY RESULT IN IMPROPER VALVE OPERATION, DAMAGE OR PERSONAL INJURY.

3.3 Installing on Tank Car

WARNING:

THE VALVE SHOULD BE TIGHTENED ON FLANGES USING APPROPRIATE GASKETS AND FASTENERS COMPATIBLE WITH THE APPLICATION, AND IN COMPLIANCE WITH APPLICABLE PIPING CODES AND STANDARDS. CENTER THE FLANGE GASKETS CAREFULLY WHEN FITTING THE VALVE BETWEEN FLANGES. DO NOT ATTEMPT TO CORRECT MISALIGNMENT BY MEANS OF FLANGE BOLTING.

The valve may be installed in any position and offers tightness in both directions. It is recommended, however, that the valve be installed with the insert (2) towards the tank car.

Refer to **Section 4, MAINTENANCE**, for stem seal adjustment. If there is weepage past the stem seals upon installation, it means the valve may have been subject to wide temperature variations in shipment. Leak-tight performance will be restored by a simply stem seal adjustment described in the **MAINTENANCE** section.

3.4 Commissioning

Ensure that there is no dirt or foreign objects left inside the valve or tank car. Flush the tank car carefully. Make sure that the valve is fully open when flushing.

Ensure that all nuts and fittings are properly fastened.

WARNING:

GOOD PRACTICE DICTATES THAT ONCE INSTALLED, BUT PRIOR TO FIRST USE, THE VALVE IS LEAK TESTED IN PLACE TO ASSURE LEAK-TIGHTNESS HAS NOT BEEN COMPROMISED BY THE INSTALLATION PROCESS. INSTALLATION ACTIONS THAT CAN CAUSE LEAKAGE INCLUDE, BUT ARE NOT LIMITED TO; WRENCHING, SOLDERING, WELDING AND/OR HOISTING. SEE **SECTION 4.5**.

3.5 Steam Jacket Connections (if applicable)

The steam-jacketed valve should be firmly attached to the tank car prior to fitting and welding of steam jacket connections. See **Section 3.3**.

The valve does not need to be disassembled prior to fitting or welding of steam jacket connections; however, the valve must be in either the fully open or fully closed position.

Carefully fit the steam lines to the valves steam jacket connections. There should be no side loads on the valves steam jacket connections due to misalignment of the steam line piping.

Welding connections should only be made by ASME, Section IX qualified welders. Additional AAR welder qualifications may apply.

An AAR certified welding inspector should inspect the steam jacket connection prior to pressure testing.

Following approval of the welds, pneumatically test the pressure tightness of the steam jacket connections to the pressure rating of the steam system on the tank car, but do not to exceed 250psig (17.2 barg.). Cover the welds with a leak detection fluid and observe for three (3) minutes. Any indication of leakage is cause for rejection.

4. MAINTENANCE

4.1 General

Although Neles *Jamesbury* valves are designed to work under severe conditions, proper preventative maintenance can significantly help to prevent unplanned downtime and in real terms reduce the total cost of ownership. Neles recommends inspecting valves at least every five (5) years. The inspection and maintenance frequency depends on the actual application and process condition. Routine maintenance consists of tightening the hex nuts (18) in (**Figure 8**) periodically to compensate for stem seal wear.

Overhaul maintenance consists of replacing seats and seals. A standard repair kit consisting of these parts may be obtained through your authorized Neles Distributor.

NOTE: Repair kits include stem bearings (70), secondary stem seal (71), seats (7), body seal (65) and stem seals (69). Refer to the Service Kit chart (see **Table 1**).

WARNING:

FOR YOUR SAFETY IT IS IMPORTANT THE FOLLOWING PRECAUTIONS BE TAKEN PRIOR TO REMOVAL OF THE VALVE FROM THE TANK CAR OR BEFORE ANY DISASSEMBLY:

1. WEAR ANY PROTECTIVE CLOTHING OR EQUIPMENT NORMALLY REQUIRED WHEN WORKING WITH THE FLUID INVOLVED.
2. DEPRESSURIZE THE TANK CAR AND CYCLE THE VALVE AS FOLLOWS:
 - A. UPON VERIFYING THE TANK CAR IS EMPTY, PLACE THE VALVE IN THE OPEN POSITION.
 - B. CYCLE THE VALVE TO RELIEVE RESIDUAL PRESSURE IN THE BODY CAVITY BEFORE REMOVAL FROM THE TANK CAR.
 - C. AFTER REMOVAL AND BEFORE ANY DISASSEMBLY, CYCLE THE VALVE AGAIN SEVERAL TIMES.
3. THESE VALVES ARE SUITABLE FOR A WIDE VARIETY OF FLUIDS AND GASES. BE CERTAIN THAT THE VALVE MATERIALS SELECTED ARE SUITABLE FOR THE APPLICATION.

4.2 Disassembly

NOTE: If complete disassembly becomes necessary, replacement of all seats, seals and bearings is recommended. (Refer to **Repair Kits, Table 1**).

NOTE: Always use original OEM parts to make sure the valve functions properly.

1. Follow the steps in all the **WARNING** Sections before performing any work on the valve.
2. Open and close the valve and leave in the closed position.
3. Secure body (1) with body joint opening facing up.
4. Remove the handle screw (35), handle (31), and retaining ring (34) from the top of the stem.
5. The insert design requires that the insert be unthreaded in a counter clockwise motion using the following method using the insert field wrench. Assemble the field wrench as follows, (refer to **Figure 9**):
 - a. Place driver (A) into the insert slots.
 - b. Put the plate (C) on top of the driver (A).
 - c. Place the studs (E) through the plate (C) and flange holes. Thread the nuts (F) onto the stud below the flange.
 - d. On the top side of the plate (C) put a flat washer (G), die spring (H), flat washer (G), and nut (F). Tighten to slightly compress springs.
6. Place a pipe or rod through the driver (A) and loosen the insert by turning counter clockwise.
7. Remove the tool and lift out the insert.

8. Place the valve in the vertical position with the insert end up.
9. Remove the body gasket (65), seat (7). Rotate the stem so that the ball is in the closed position and remove the ball (3). **BE CAREFUL NOT TO SCRATCH OR DAMAGE BALL WHEN REMOVING FROM VALVE BODY.** The spring (36), which is between the bottom of the stem and the ball, may fall out at this time. If the spring does fall out with the ball, remove it from the stem to prevent it from being lost. A piece of wood or other soft material may be used to unseat the parts from the opposite side.
10. Remove the second seat (7) from the body (1). **BE CAREFUL NOT TO SCRATCH THE BODY SEALING SURFACE BEHIND THE SEAT.** A piece of wood or other soft material may be used to unseat the parts from the opposite side.
11. Remove retaining ring (34), off the spring (33) and indicator stop (32).
12. Remove the stud nuts (18).
13. Remove the stop bushings (39) and compression plate (10).
14. Press the stem (5) from the top into the valve body and remove it through the end of the body. **BE CAREFUL NOT TO SCRATCH ANY SEALING SURFACES ON THE STEM OR IN THE BODY.**
15. Remove the old stem bearings (70), and secondary stem seal (71). **BE CAREFUL NOT TO SCRATCH ANY SEALING SURFACES IN THE BODY.**
16. Remove the stem seals/v-ring set (69). **BE CAREFUL NOT TO SCRATCH ANY SEALING SURFACES IN THE STEM BORE.**

4.3 Checking Parts

NOTE: For detailed instructions on visual inspection of critical components, refer to IMO-R26.

1. Clean all disassembled parts.
2. Check the stem (5) and ball (3) for damage. Pay particular attention to the sealing areas.
3. Check all sealing and gasket surfaces of the body (1) and body cap (2). Also sealing surfaces should be clean, with no corrosion, old seal material or commodity residue.
4. Inspect in threads of in seat and body. Dry fit insert into body thread to check fits.
5. Replace any fastener where the threads are damaged or have been heated, stretched or corroded.
6. Replace any damaged parts.
7. Replace any parts that have cracks, gouges or pits that will affect sealing.

4.4 Assembly

It is advisable to replace seats and seals if complete disassembly and reassembly becomes necessary. Refer to the Service Kit chart (see **Table 1**). A good lubricant compatible with the tank car commodity **MUST** be applied to the insert threads to prevent galling during assembly.

1. Clean all valve components if not done previously.
2. Re-inspect all components for damage before reassembling the valve. Look for damage to the seating areas, stem, body and body cap; and look for wear in the bearing areas. Replace any damaged parts.
3. Carefully clean and polish the ball (3) sealing surface. It should be free of all scratches and grooves.
4. If the ball is slightly damaged, it may be possible to smooth the sealing surface with crocus cloth or equivalent. If deep scratches are present, replace the ball.
5. Secure body (1) with body joint opening facing up.
6. Slide one valve seat (7) sideways into the body (1) to below the stem bore, and tilt it into place so that the proper surface (see **Figure 3**) will be adjacent to the ball (3), being careful not to cut or scratch the seat.

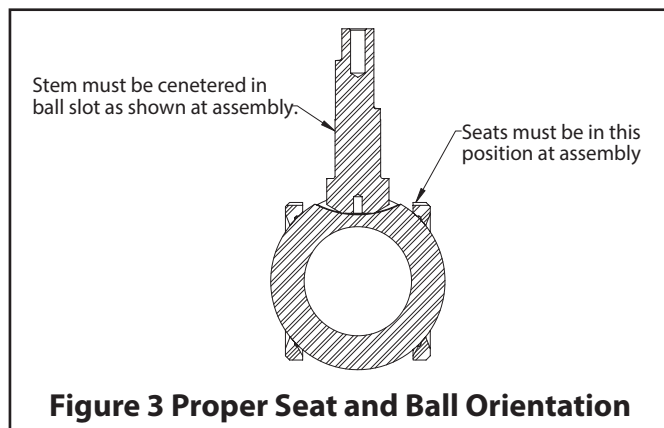

7. For Fire-tite®, Place the stem bearings (70) and secondary stem seal (71) as shown in **Figure 4** on the stem. For non *Fire-tite* place the stem bearing (70) on the stem. See How to Order Section to determine proper valve construction.

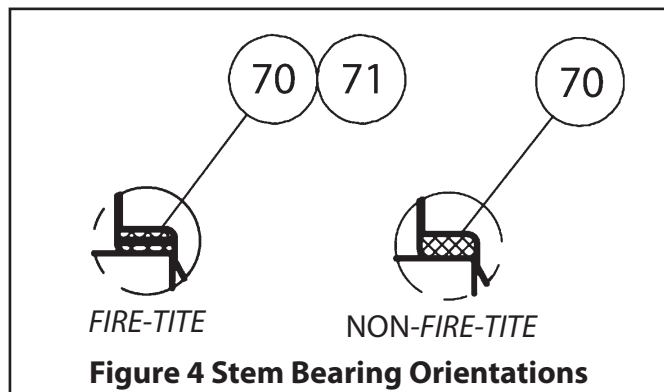

8. Insert the stem (5), through the insert end of the body, being careful not to scratch the stem sealing surface; and press it gently up into the stem bore until resistance is felt from the stem bearing. Holding the stem in place from the bottom, insert the stem seals (69) over the stem (5). (see **Figure 5** for proper V-ring and graphite seal orientation).

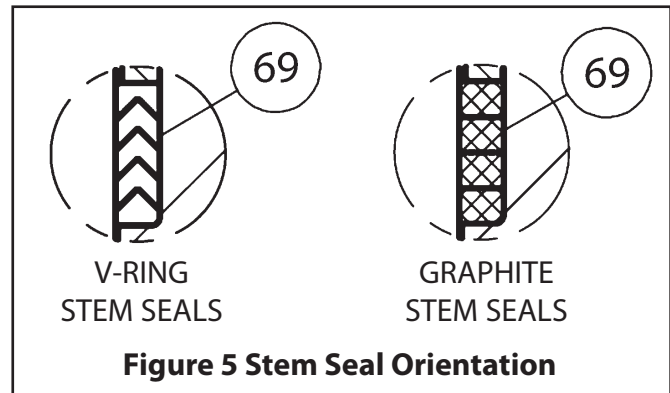

9. Place the compression plate (10) over the studs (14). Place one stop bushing (39) over each stud (14).
10. Place a stud lock nut (18) on each stud (14) and tighten nuts alternatively so that the compression plate (10) remains parallel with the body. Tighten down the nuts until the stem seals/v-ring set is fully seated, then tighten the nuts and additional 1/4 turn. If necessary, retighten the stud nuts (18) until the plate is level.

WARNING:

IF THE COMPRESSION PLATE IS NOT LEVEL AND PARALLEL TO THE BODY, AN UNEVEN LOAD IS APPLIED TO THE STEM SEALS AND MAY RESULT IN LEAKAGE AND PREMATURE WEAR.

NOTE: Check all fastener threads for damage. Ensure fasteners are not bent or deformed. Assure nuts can be assembled the full length of the fastener with no more than finger tight force. Fastener grade markings must be visible after assembly.

11. Screw the insert (2) into the body until it is fully seats, and then mark its position as shown in **Figure 6**. Counting the number of turns, remove the insert.
12. Place the valve in a vertical position, body joint up, on a clean soft surface such as a folded rag or piece of cardboard. Insert bottom grounding spring (36) into the hole at the bottom of the stem (5). Insert the ball (3) rotating it onto the stem (5) in the closed position. If necessary, turn the stem blade to align with the ball slot. Make certain that the stem blade is in the middle of the ball slot; i.e. equal distance from the ends of the slot. Rotate the ball if necessary (see **Figure 3**).
13. Place the second seat (7) into the insert (2) with the proper surface adjacent to the ball (see **Figure 3**).
14. Gently place the body gasket (65) into the machined recess of the body (1).

15. Apply a lubricant compatible with the tank car commodity to the insert threads and screw the insert into the body. The tightening of the insert should be done using the insert field wrench. The insert must be tightened the same number of turns as in Step 11, insuring that the marks are no more than 1/8" (3.18 mm) apart, as shown in **Figure 7**.
16. Place the indicator stop (32) with "BTM" making facing down, over the stem so that the longer part is over the body.
17. Place the spring (33) over the stem (5) with the larger diameter contacting the indicator stop (32).
18. Compress the spring (33) and hold down by putting the retaining ring (34) in the groove in the stem (5).
19. If the valve is to be grounded, test as follows:
 - a. User an ohmmeter accurate to within +/- 10%
 - b. Check continuity between top of stem and body base metal. Also check between ball and body base metal. Precaution should be taken to prevent scratching the ball OD.
 - c. Resistance in either the open, half open or closed position shall not exceed 5 ohms using a source not exceeding 12 volts.

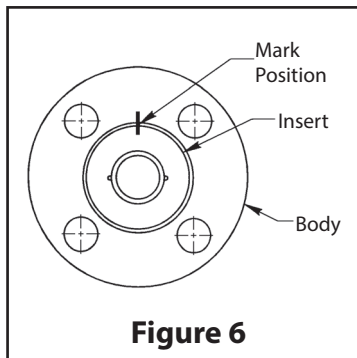

Figure 6

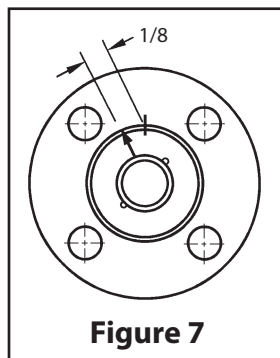

Figure 7

20. With the ball in the open position, install handle (31) and handle screw (35). **NOTE:** With the ball in the open position the handle must be over the non-insert end of the valve.
21. Cycle the valve slowly a few times to assure smooth operation and to set the seats.

4.5 Pressure Testing the Valve

WARNING:

WHEN PRESSURE TESTING, EXERCISE CAUTION AND MAKE SURE ALL EQUIPMENT USED IS IN GOOD WORKING CONDITION AND APPROPRIATE FOR THE INTENDED PRESSURE.

If the valve is to be tested prior to returning to service, make sure the test pressures are in accordance with an applicable standard.

When testing the valve for external tightness, keep the ball in the half open position.

If testing the valve seat tightness, please contact Neles for advice.

WARNING:

WHEN PERFORMING ANY TESTS, NEVER EXCEED THE MAXIMUM OPERATING PRESSURE OR MAXIMUM SHUT-OFF PRESSURE LISTED ON THE IDENTIFICATION PLATE.

5. REPAIR KITS

Standard repair kits are listed in (**Table 1**). When ordering repair kits for your valve refer to **Section 1.2, Valve Markings** and check area "3" on your valve's identification plate determine the correct seat material for your valve.

6. SERVICE/SPARE PARTS

We recommend that valves be directed to our service centers for maintenance. The service centers are equipped to provide rapid turn-around at a reasonable cost and offer new valve warranty with all reconditioned valves.

NOTE: When sending goods to the service center for repair, do not disassemble them. Clean the valve carefully and flush the valve internals. Include the material safety datasheet(s) (MSDS) for all media flowing through the valve. Valves sent to the service center without MSDS datasheet(s) will not be accepted.

For further information or assistance on repair kits and spare parts, visit our website at <https://www.neles.com/products/valves/railroad-valves/>.

NOTE: When ordering spare parts not included in repair kits, always include the following information:

- a. Valve catalog code from identification plate
- b. If the valve is serialized, the serial number (stamped on the valve body)
- c. From **Figure 8**, the ballooned part number, part name and quantity required.

7. EXPLODED VIEW - VALVE

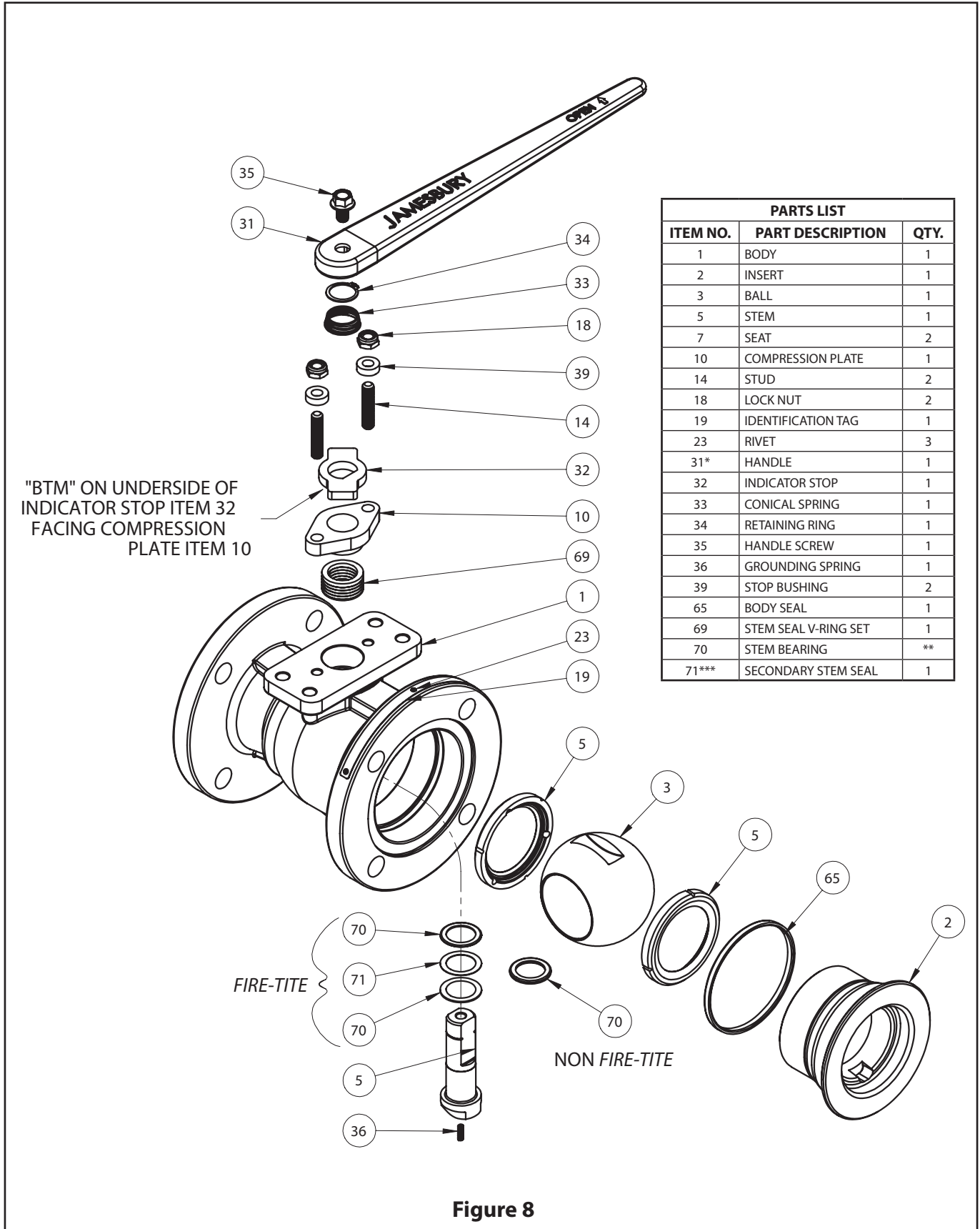

8. EXPLODED VIEW - INSERT FIELD WRENCH

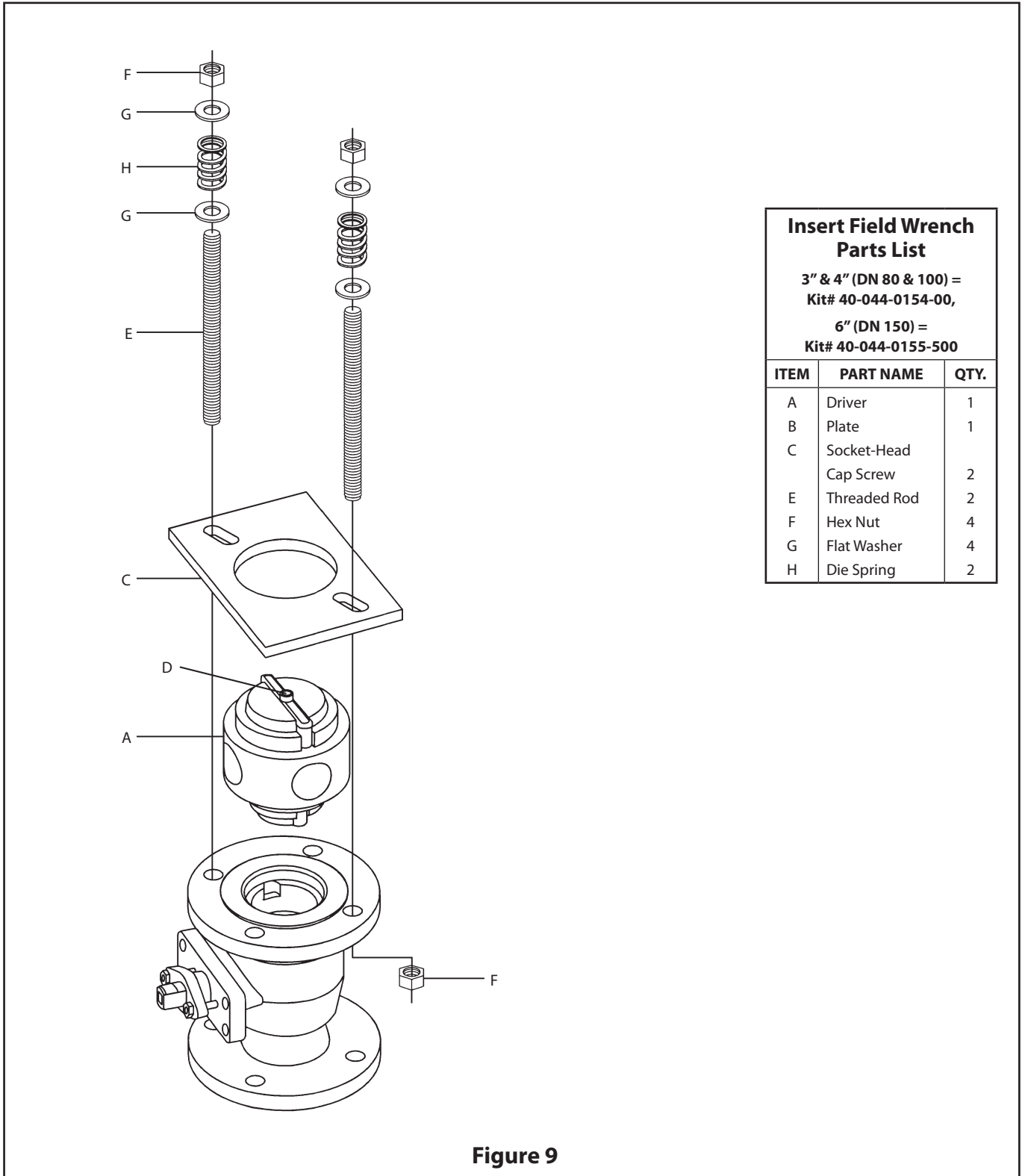

Insert Field Wrench Parts List		
3" & 4" (DN 80 & 100) = Kit# 40-044-0154-00,		
6" (DN 150) = Kit# 40-044-0155-500		
ITEM	PART NAME	QTY.
A	Driver	1
B	Plate	1
C	Socket-Head	1
	Cap Screw	2
E	Threaded Rod	2
F	Hex Nut	4
G	Flat Washer	4
H	Die Spring	2

Figure 9

Table 1 - Repair Kits**Valve Size**

Seat Material	3"(DN 80) 7150/7300	4"(DN 100) 7150	6"(DN 150) 7150
PTFE (T)	RKN-174TTT	RKN-175TTT	RKN-196TTT
Filled PTFE (M)	RKN-174MTT	RKN-175MTT	RKN-196MTT
PFA Seats & Seals	RKN-174BPT	RKN-175BPT	RKN-196BPT
XTREME®	RKN-174XTZ	RKN-175XTZ	RKN-196XTZ

*For grounded valves, grounding washers listed below are also needed for ordering. (One per valve)

	3"(DN 80)	4"(DN 100)	6"(DN 150)
Class 150	004 0847 60	004 0847 60	004 0848 60
Class 300	004 0847 60	-	-

9. HOW TO ORDER JAMESBURY 7000 SERIES RAILROAD VALVES

1	2	3	4	5	6	7		
3	7150	RR	31	22	36	XTZ	1	A

1. sign	Valve Size (Inch / mm)
INCHES	3", 4", 6"
DN	80, 100, 150

2. sign	Valve Series & Style	Size Range
7150	Standard Bore Class 150	3", 4", 6"
7300	Standard Bore Class 300	3"
730S	Standard Bore Class 300	3"

3. sign	Special Construction
RR	Railroad Service

4. sign	End Connection Construction	Size Range
11	Raised Face Non-Fire-tite Non-trunnion	3", 4", 6" Class 150 3" Class 300
31	Raised Face Fire-tite Non-trunnion	3", 4", 6" Class 150 3" Class 300

5. sign	Body Material	Size Range
22	Carbon Steel (WCB)	All
35	Alloy 20 (CN7M)	Optional in all Sizes
36	Stainless Steel (CF8M)	All
71	Monel®	Optional in all Sizes

6. sign	Ball & Stem Material	Size Range
00**	Same as body	All (Carbon steel not available)
36	Stainless Steel (CF8M)	All
71	Monel	Optional in all Sizes
73	Hastelloy®	Optional in all Sizes

** Use code 00 when trim matches the body material

7. sign	Seat & Seal Material	Size Range
XTZ	Xreme	All
TTT	PTFE	All

8. sign	Bolts	Nuts	Application
1	ASTM A193 Gr B7	ASTM A194 Gr 2H	Carbon Steel Monel
2	ASTM A193 Gr B8, B8C, B8M or B8T (Class 2)	ASTM A194 Gr 8B, 8CB, 8MB or 8TB, or 8FB	316 St. Stl. Alloy 20
4	Monel		Monel All NACE All Cl2
5	ASTM A193 Gr B7M	ASTM A194 Gr 2HM	All NACE

9. sign	Model
A	Model A

Neles

Vanha Porvoontie 229, 01380 Vantaa, Finland.
Tel. +358 10 417 5000.

neles.com