

# Medical Grade Power Strips with Load Monitoring Inform™ Technology

PK-A3311-10-02-0A

Rated Max: 125 VAC, 60 Hz, 12 Amp Regulatory Derated		
	4 Outlet	6 Outlet
<b>Non-Surge</b>	53C4M-1Nx	53C6M-1Nx
<b>Surge</b>	53C4M-1Sx	53C6M-1Sx
<b>x = Length of cord:</b> 5 = 15ft (4.57m) cord and 7 = 7ft (2.13m) cord		

Rated Max: 125 VAC, 60 Hz, 16 Amp Regulatory Derated		
	4 Outlet	6 Outlet
<b>Non-Surge</b>	53C4M-2Nx	53C6M-2Nx
<b>Surge</b>	53C4M-2Sx	53C6M-2Sx
<b>x = Length of cord:</b> 5 = 15ft (4.57m) cord and 7 = 7ft (2.13m) cord		

## WARNINGS:

- **TO AVOID FIRE, do not** plug into another re-locatable power tap or extension cord.
- To be installed and/or used in accordance with appropriate electrical codes and regulations.
- If you are not sure about any part of these instructions, consult an electrician.
- Only connect to a properly grounded outlet.

## WARNINGS FOR SURGE MODELS ONLY:

- **Do not** install this device if there is not at least 30 feet (10 meters) or more of wire between the electrical outlet and the electrical service panel.
- This device features internal protection that will disconnect the surge protective component at the end of its useful life but will maintain power to the load now unprotected. If this situation is undesirable for the application, follow the manufacturer's instructions for replacing the device.

## CAUTIONS:

- **FOR INDOOR USE ONLY.**
- Electromagnetic field may interfere with other equipment. If interference occurs, move medical strip away from equipment being affected.
- No user serviceable parts inside.
- Only outlet Medical Grade power strips can be used with emergency trolley carts.
- The socket outlet should be installed near the equipment and be easily accessible.

## IMPORTANT SAFETY INSTRUCTIONS SAVE THESE INSTRUCTIONS

## INSTALLATION

ENGLISH

## DESCRIPTION

Leviton's Medical Grade Power Strips are designed for use in rugged medical environments such as patient care areas. They comply with UL 60601-1 (Medical Electrical Equipment) and UL 60950-1 (Information Technology Equipment) standards and are certified to UL 1363A (Special Purpose Re-locatable Power Tap) to supply power to plug-connected medical equipment in patient care vicinities as defined in NFPA 99. These power strips have ETL determined compliance to all UL standards mentioned in this instruction sheet.

These Medical Grade Power Strips are available in non-surge and surge models. Surge models meet the UL 1449 3rd Edition standard and are classified as Type 3 surge protective devices. The strips are available in 4 or 6 outlet versions with 7 or 15 foot power cords. Each outlet is protected by a unique cover designed specifically for patient care areas.

For a list of all standards and compliance see specifications section below.

## SPECIFICATIONS

### All Models

- 5 Year Limited Warranty
- NFPA 99 - Complies with requirements as it pertains to patient care vicinities.
- UL 60601-1, UL 60950-1, UL 1363A
- Hospital Grade receptacles
- Hospital Grade molded plug
- Lockable individual outlet covers
- Resettable, 15 or 20 Amp circuit breaker
- Rugged metal housing
- Easily accommodates surface mounting
- Green power LED indicates power is present
- Yellow load monitoring LED is on all models
- Class 1 equipment
- Operating temperature: 0°C to 40°C (32°F to 104°F)
- Relative humidity: 5% to 95% non-condensing
- Transport and storage temperature: -10°C to +50°C (14°F to +122°F)

### Surge Models Only

- UL 1449 3rd Ed. Type 3 device
- 18mm MOV fused SPD circuitry
- Green protection LED indicates surge protection is active
- Multi-line protection (L-N, N-G, L-G).
- Voltage Protection Ratings (VPR):  
L-N: 600Vpk  
L-G: 600Vpk  
N-G: 500Vpk
- Maximum surge current rating per mode: (L-N): 27kA
- Joule rating: 644j
- Maximum Continuous Operating Voltage (MCOV): 150 V
- EMI/RFI noise reduction: -6db to -29db (100kHz to 100mHz)

## OPERATION

1. Plug power cord into 125 VAC outlet.
2. **All Models:** The green "POWER" LED will illuminate when power is applied. "LOAD MONITOR" LED will illuminate Yellow when power strip exceeds the NFPA 99 75% of allowable amperage.  
**Surge Models only:** The green "PROTECTION" LED will illuminate when surge protection is active.
3. To open outlet cover, use a plug blade of the component to be plugged in as shown in **FIGURE 1**.
4. To close cover, press down until it snaps closed.
5. Operating symbols:
  - Power LED: Indicates power is present when lit.
  - Protection LED (**surge models only**): Indicates surge protection is active when lit.
  - Load Monitor: Steady Yellow LED indicates unit exceeds 75% of amperage.
  - ●: Green dot indicates hospital grade outlet.
  - ~: AC Symbol indicates alternating current.
  - ⊕: Earth ground symbol indicates grounding electrical point.
  - Δ: Meets direct support requirements for current carrying parts at 120 V rms or less and 15 A or less.

## LOAD MONITORING:

This power strip contains a load monitoring feature which will notify the user when 75% of the rated cord current has been reached. A rule under the NFPA 99 states: "The sum of the ampacity of all appliances connected to the outlets does not exceed 75 percent of the ampacity of the flexible cord supplying the outlets".  
Note: A momentary blink of the yellow load monitoring LED may occur when a load is applied. This is due to inrush current briefly exceeding the 75% limit. As long as the steady-state condition of the load monitoring LED is not illuminated, the load is within the NFPA 99 allowable limit.

## INSTALLATION - FLYING LEADS MODELS ONLY

Models containing flying leads (no power plug) must be hardwired correctly to maintain power, protection and polarity status.

1. **WARNING: TO AVOID FIRE, SHOCK, OR DEATH; TURN OFF POWER** at circuit breaker or fuse and test that power is off before wiring!
2. Connect leads to 125 VAC single phase power source as shown in **FIGURE 2**.
3. Restore power at circuit breaker or fuse.

## MOUNTING

Medical strips can be surface mounted using mounting holes on either end of strip.

1. Mark mounting surface using medical strip as template.
2. Drill holes and attach strip using screws (**not supplied**).
3. Refer to **FIGURE 3** for mounting dimensions.

## CARE AND MAINTENANCE

**WARNING:** Do not spray with liquid cleaning products.

- To clean, unplug unit and wipe with a clean cloth.
- Check status LEDs monthly. Normal operation requires LEDs to be lit.
- Check circuit breaker (CB) status monthly. Normal operation requires CB to be depressed.

## FOR CANADA ONLY

For warranty information and/or product returns, residents of Canada should contact Leviton in writing at Leviton Manufacturing of Canada ULC to the attention of the Quality Assurance Department, 165 Hymus Blvd, Pointe-Claire (Quebec), Canada H9R 1E9 or by telephone at 1 800 405-5320.

## LIMITED 5 YEAR WARRANTY AND EXCLUSIONS

Leviton warrants to the original consumer purchaser and not for the benefit of anyone else that this product at the time of its sale by Leviton is free of defects in materials and workmanship under normal and proper use for five years from the purchase date. Leviton's only obligation is to correct such defects by repair or replacement, at its option. For details visit [www.leviton.com](http://www.leviton.com) or call 1-800-824-3005. This warranty excludes and there is disclaimed liability for labor for removal of this product or reinstallation. This warranty is void if this product is installed improperly or in an improper environment, overloaded, misused, opened, abused, or altered in any manner, or is not used under normal operating conditions or not in accordance with any labels or instructions. **There are no other or implied warranties of any kind, including merchantability and fitness for a particular purpose, but if any implied warranty is required by the applicable jurisdiction, the duration of any such implied warranty, including merchantability and fitness for a particular purpose, is limited to five years. Leviton is not liable for incidental, indirect, special, or consequential damages, including without limitation, damage to, or loss of use of, any equipment, lost sales or profits or delay or failure to perform this warranty obligation.** The remedies provided herein are the exclusive remedies under this warranty, whether based on contract, tort or otherwise.

For Technical Assistance Call: 1-800-824-3005 (USA Only) or 1-800-405-5320 (Canada Only) [www.leviton.com](http://www.leviton.com)

PK-A3311-10-02-0A

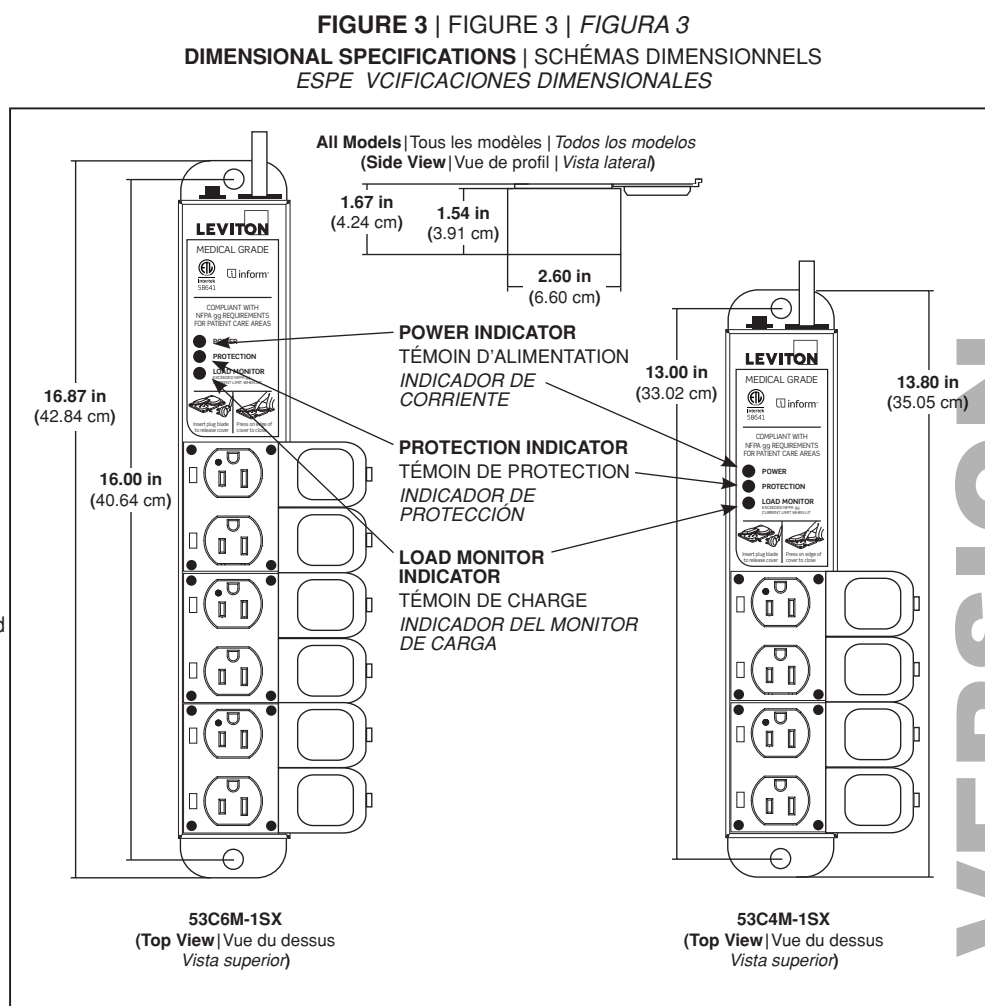
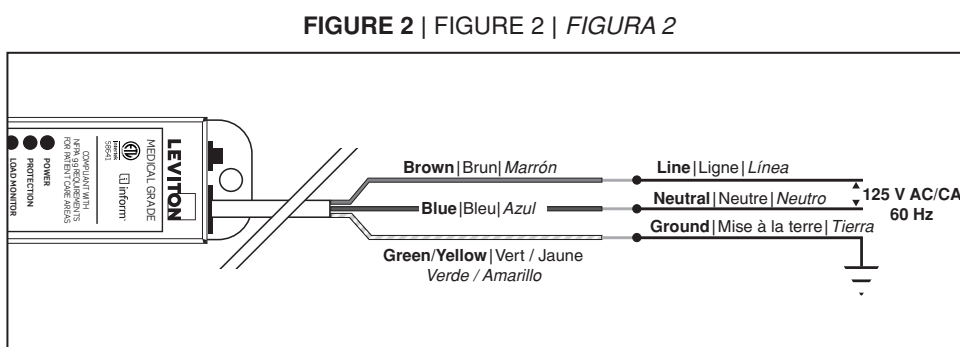
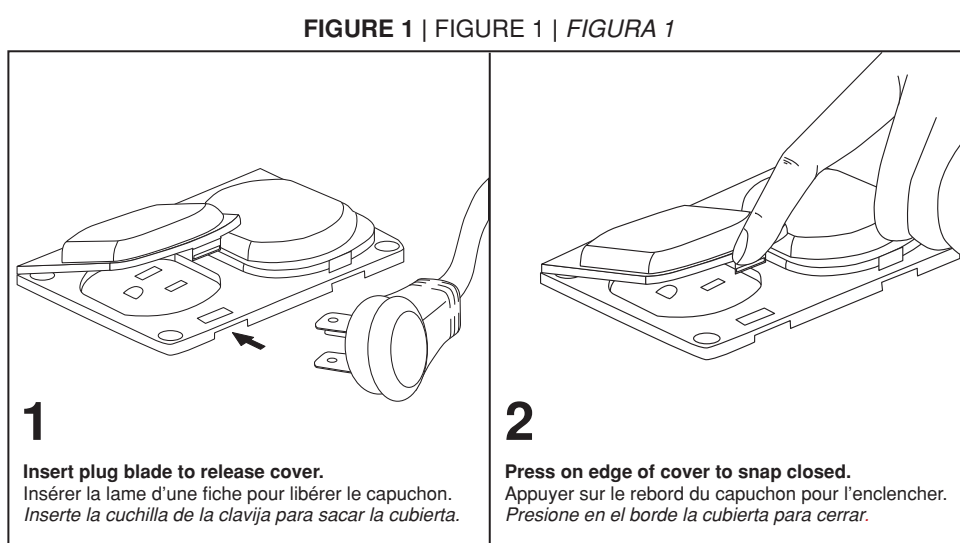

REVISION

