

Breaker current sensor and rating plug replacement kit

⚠ WARNING

DO NOT ATTEMPT TO INSTALL OR PERFORM MAINTENANCE ON EQUIPMENT WHILE ENERGIZED. BREAKER MUST REMAIN IN THE "OPEN" AND "DISCHARGED" CONDITION DURING THE INSTALLATION OF THIS ACCESSORY KIT. DEATH OR SEVERE PERSONAL INJURY CAN RESULT FROM CONTACT WITH ENERGIZED EQUIPMENT. ALWAYS VERIFY THAT NO VOLTAGE IS PRESENT BEFORE PROCEEDING. MANUFACTURER/SUPPLIER ASSUMES NO RESPONSIBILITY FOR DAMAGE DONE TO CIRCUIT BREAKERS OR OTHER EQUIPMENT DURING FIELD INSTALLATION OF ANY ACCESSORY.

Section 1: General information

Required tools

- Phillips head screwdriver (#2 recommended)
- Slot head screwdriver

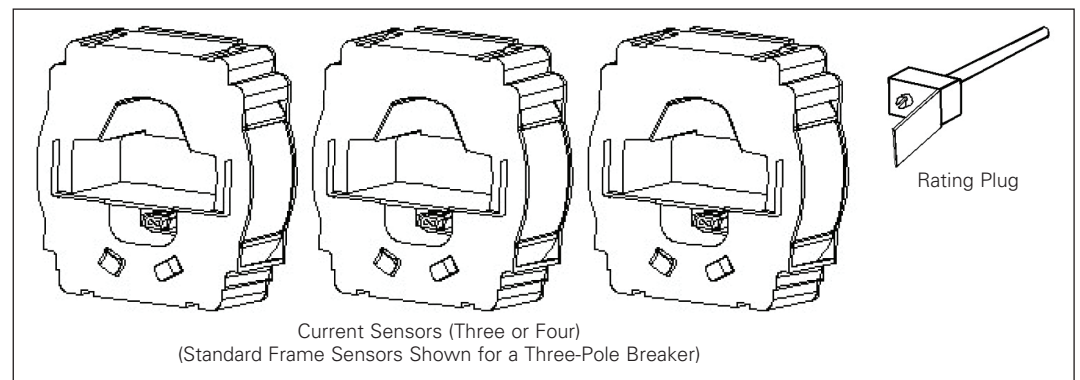

Figure 1. Contents of Kit

EAT•N

Powering Business Worldwide

Section 2: Installation

Step 1: Remove current sensor door. Unscrew the #10 x 5/8-inch long self-threading screws (seven in a three-pole breaker; nine in a four-pole breaker).

Step 2: Remove existing sensors (if equipped). Remove and unplug them from the connected wiring.

Step 3: Install new sensors. Plug new sensors (one required per pole) to existing plug connector. Slide connected sensor into housing as shown in **Figure 3** while feeding wiring into cavity below load conductor terminals.

Step 4: Reinstall current sensor door. Locate door back in place of breaker and carefully insert screws into the existing cut threads.

Step 5: Remove trip unit cover. Remove cover by loosening two screws.

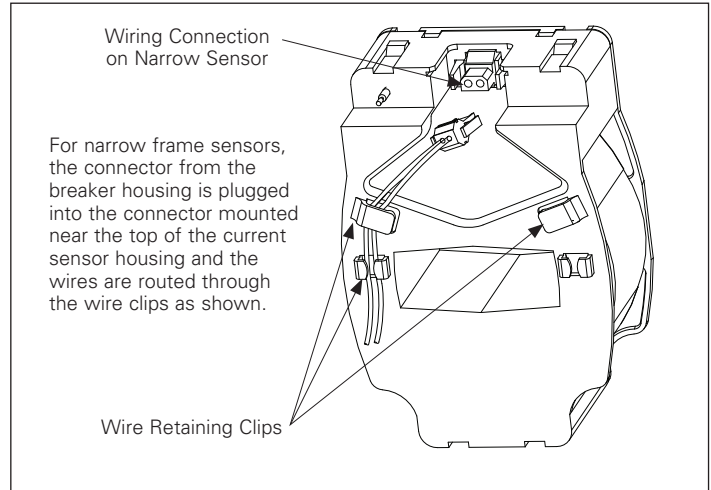

Figure 2. Narrow Frame Sensor Installation

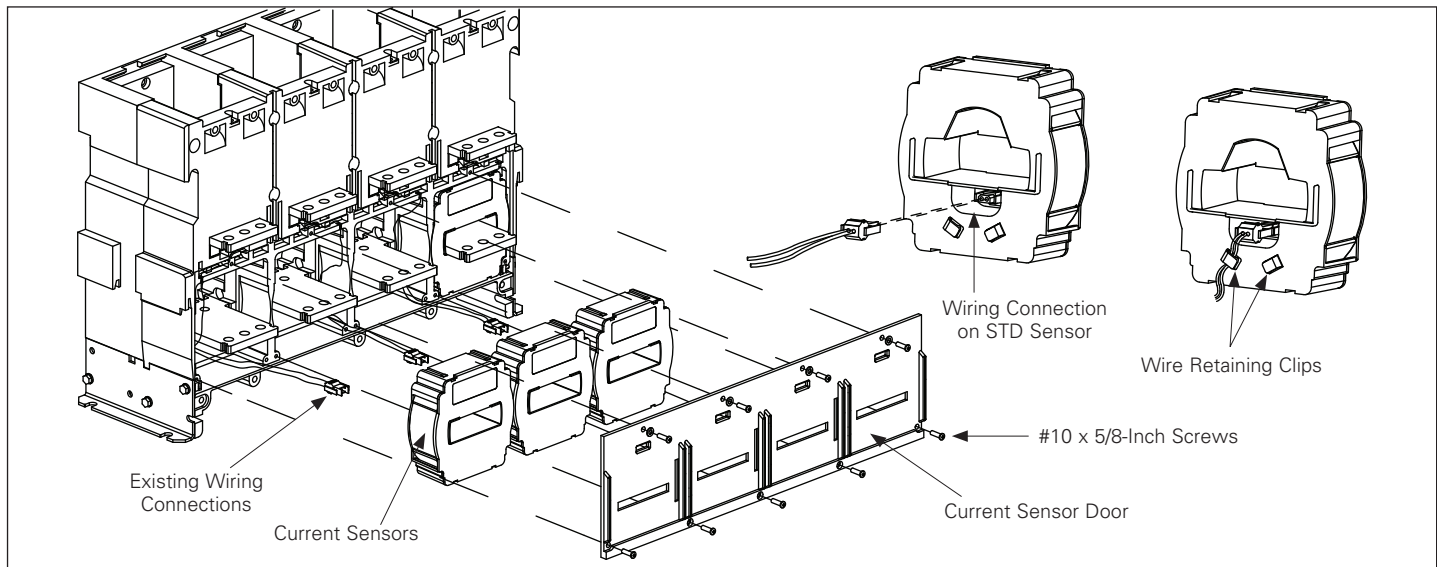

Figure 3. Step 3

Step 6: Remove existing rating plug. If trip unit is already equipped with a rating plug, remove it by opening the rating plug hinged door and unscrewing the slotted screw located behind the door. Now gently pull the rating plug straight out.

Step 7: Insert new rating plug. Carefully insert new rating plug into the rating plug location in the trip unit, open the hinged door, and screw lightly into place (torque should be no more than 17 in lbs or 2nM.)

Step 8: Reinstall trip unit cover.

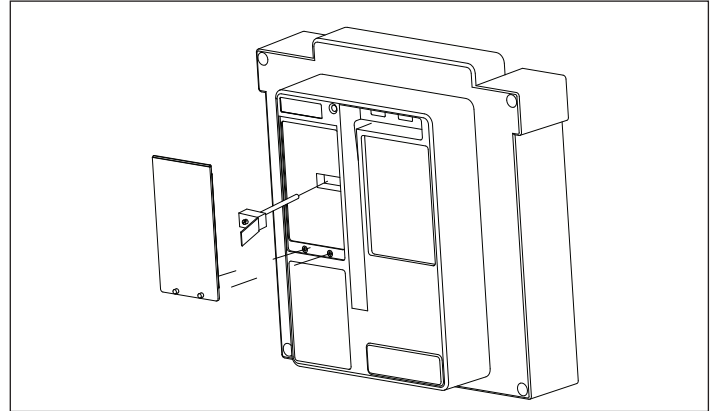

Figure 4. Step 6

Disclaimer of warranties and limitation of liability

The information, recommendations, descriptions, and safety notations in this document are based on Eaton Corporation's ("Eaton") experience and judgment, and may not cover all contingencies. If further information is required, an Eaton sales office should be consulted.

Sale of the product shown in this literature is subject to the terms and conditions outlined in appropriate Eaton selling policies or other contractual agreement between Eaton and the purchaser.

THERE ARE NO UNDERSTANDINGS, AGREEMENTS, WARRANTIES, EXPRESSED OR IMPLIED, INCLUDING WARRANTIES OF FITNESS FOR A PARTICULAR PURPOSE OR MERCHANTABILITY, OTHER THAN THOSE SPECIFICALLY SET OUT IN ANY EXISTING CONTRACT BETWEEN THE PARTIES. ANY SUCH CONTRACT STATES THE ENTIRE OBLIGATION OF EATON.

THE CONTENTS OF THIS DOCUMENT SHALL NOT BECOME PART OF OR MODIFY ANY CONTRACT BETWEEN THE PARTIES.

In no event will Eaton be responsible to the purchaser or user in contract, in tort (including negligence), strict liability, or otherwise for any special, indirect, incidental, or consequential damage or loss whatsoever, including but not limited to damage or loss of use of equipment, plant or power system, cost of capital, loss of power, additional expenses in the use of existing power facilities, or claims against the purchaser or user by its customers resulting from the use of the information, recommendations, and descriptions contained herein.

The information contained in this manual is subject to change without notice.

Eaton Corporation
Electrical Sector
1000 Cherrington Parkway
Moon Township, PA 15108
United States
877-ETN-CARE (877-386-2273)
Eaton.com

© 2011 Eaton Corporation
All Rights Reserved
Printed in USA
Publication No. IL2C13762H01 / Z10725
January 2011



PowerChain
Management®

PowerChain Management is a registered trademark of Eaton Corporation.

All other trademarks are property of their respective owners.