

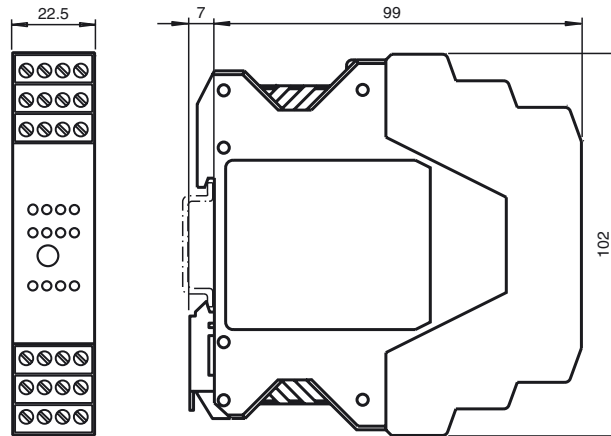

Dimensions

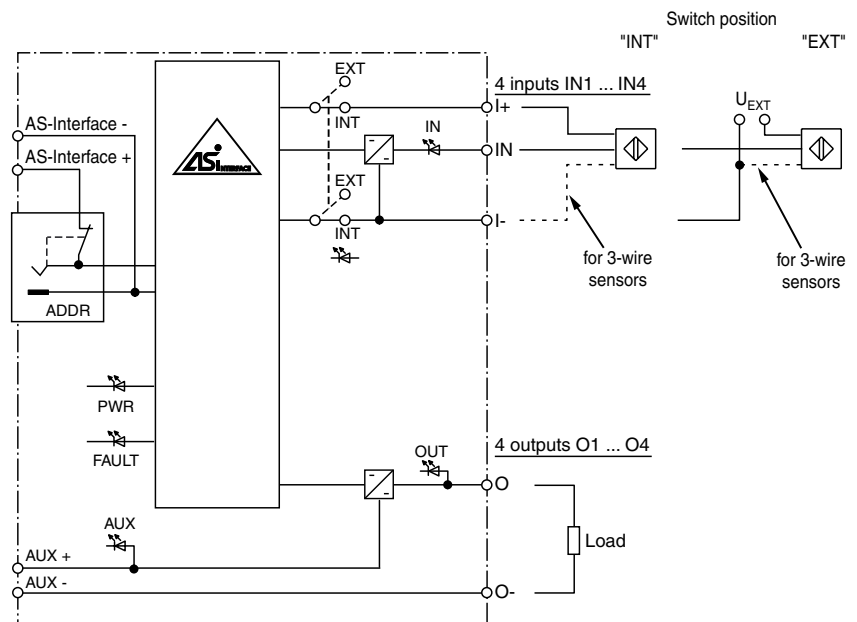

Electrical connection



Model number

VBA-4E4A-KE-ZEJQ/E2L

KE switch cabinet module
4 inputs and 4 outputs

Features

- Housing with removable, mechanical and color coded terminals
- Communication monitoring
- Inputs for 2- and 3-wire sensors
- Addressing jack
- Power supply of outputs from the external auxiliary voltage
- Selectable supply to the sensors: External or from the module
- Function display for bus, external auxiliary voltage, internal sensor supply, inputs, and outputs
- Red LED per channel, lights up in the event of output overload
- Switchable lead breakage detection (outputs)

Indicating / Operating means

ATTENTION

Do not connect the terminals I+, IN and I- with any external potential when switch set to "INT"

Sensor supply:
INT = internal sensor supply (from AS-i)
EXT = external sensor supply

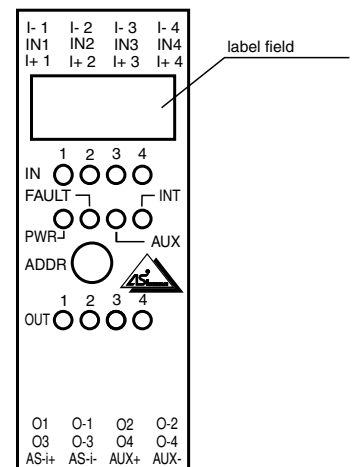
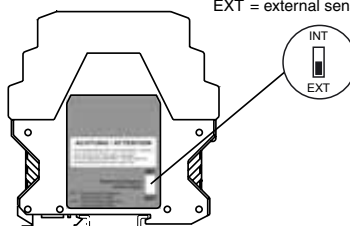

Release date: 2015-09-08 09:39 Date of issue: 2016-07-11 217801_eng.xml

Technical data

General specifications

| | |
|-------------------------------|-----------|
| Slave type | A/B slave |
| AS-Interface specification | V3.0 |
| Required master specification | ≥ V3.0 |
| UL File Number | E223772 |

Functional safety related parameters

| | |
|--------------------------------|-------|
| MTTF _d | 190 a |
| Mission Time (T _M) | 20 a |
| Diagnostic Coverage (DC) | 0 % |

Indicators/operating means

| | |
|-----------|---|
| LED FAULT | Error display; red LED red: communication error, i.e. address is 0 red flashing: overload internal input supply, i.e. overload or lead interruption outputs |
| LED INT | Internal input supply active; LED green |
| LED PWR | AS-Interface voltage; green LED green: voltage OK flashing green: address 0 |
| LED AUX | ext. auxiliary voltage U _{AUX} ; dual LED green/red green: voltage OK red: reverse voltage |
| LED IN | switching state (input); 4 LED yellow |
| LED OUT | switching state (output); 4 LED yellow/red yellow: output active red: output overload or lead interruption |

Electrical specifications

| | | |
|----------------------------|------------------|---|
| Auxiliary voltage (input) | U _{EXT} | 12 ... 30 V DC PELV |
| Auxiliary voltage (output) | U _{AUX} | 20 ... 30 V DC PELV |
| Rated operating voltage | U _e | 26.5 ... 31.6 V from AS-Interface |
| Rated operating current | I _e | ≤ 35 mA (without sensors) / max. 190 mA |
| Protection class | | III |
| Surge protection | | U _{EXT} , U _{AUX} , U _e : overvoltage category II, safe isolated power supplies (PELV) |

Input

| | |
|--------------------------|--|
| Number/Type | 4 inputs for 2- or 3-wire sensors (PNP), DC |
| Supply | from AS-Interface (switch position INT, default settings) or external U _{EXT} (switch position EXT) |
| Voltage | 21 ... 31 V DC (INT) |
| Current loading capacity | ≤ 150 mA, overload- and short-circuit protected (INT) |
| Input current | ≤ 9 mA (limited internally) |
| Switching point | according to DIN EN 61131-2 (Type 2) |
| 0 (unattenuated) | ≤ 3 mA |
| 1 (attenuated) | ≥ 5 mA |
| Signal delay | < 1 ms (input/AS-Interface) |

Output

| | |
|----------------|--|
| Number/Type | 4 electronic outputs, PNP, overload and short-circuit proof |
| Supply | from external auxiliary voltage U _{AUX} |
| Current | 2 A per output, sum 4A (T _B ≤ 40 °C) 0.5 A per output, total 2A (T _B ≤ 60 °C, arranged in series without gaps) 2 A per output, total 4A (T _B ≤ 60 °C, arranged in series with 5 mm gap) |
| Voltage | ≥ (U _{AUX} - 0.5 V) |
| Usage category | DC-13 |

Programming instructions

| | |
|----------|---------|
| Profile | S-7.A.7 |
| IO code | 7 |
| ID code | A |
| ID1 code | 7 |
| ID2 code | 7 |

| Data bits (function via AS-Interface) | input | output |
|---------------------------------------|-------|--------|
| D0 | IN1 | O1 |
| D1 | IN2 | O2 |
| D2 | IN3 | O3 |
| D3 | IN4 | O4 |

Parameter bits (programmable via AS-i) function

| | |
|----|--|
| P0 | Communication monitoring P0 = 0 monitoring = off, the outputs maintain the status if communication fails P0 = 1 monitoring = on, i.e. if communication fails, the outputs are deenergised (default settings) |
| P1 | Input filter P1 = 0 input filter on, pulse suppression ≤ 2 ms P1 = 1 input filter off (default settings) |
| P2 | Lead breakage outputs P2 = 0 lead breakage on P2 = 1 lead breakage off (default settings) |
| P3 | not used |

Function

The AS-Interface I/O module VBA-4E4A-KE-ZEJQ/E2L is a control cabinet module with 4 inputs and 4 electronic outputs. The housing is only 22.5 mm wide and takes up little space in the control cabinet. The module is mounted by snapping onto the 35-mm DIN rail in compliance with EN 50022.

The connection is made via plug-in terminals. Four-terminal blocks (black) are used for the inputs and outputs. The connection of the external bulk power and the AS Interface is via 2-terminal blocks (bulk power grey, AS-Interface yellow). Terminals for the inputs and outputs are mechanically coded to prevent incorrect connection.

The supply to the inputs and the connected sensors can be fed either from the internal supply of the module (from the AS-Interface) or via an external voltage source. A switch located on the side of the module changes the supply source. The choice of internal input supply is displayed via the INT LED. The IN and OUT LEDs display the current switching status of the relevant inputs and outputs. The OUT LED also indicates an overload or a lead breakage at the associated output.

Note:

The device is equipped with a communication monitor, which deactivates the outputs if the AS-Interface does not communicate with the module for more than 40 ms. The communication monitor can be deactivated via the parameter P0. Filters that suppress pulses with a duration of 2 ms or less at the inputs can be connected via the parameter P1.

Parameter P2 activates a lead breakage detection system for the outputs. This function detects and reports a missing load, providing the relevant output is deactivated. The associated OUT LED and the 'peripheral fault' function display the signal transmitted to the AS-Interface master. A signal indicating an overload of the internal input supply or the outputs is also transmitted to the AS-Interface master via the 'peripheral fault' function. Communication via the AS-Interface continues even if a peripheral fault is set.

Accessories

VBP-HH1-V3.0-KIT

AS-Interface Handheld with accessory

VBP-HH1-V3.0

AS-Interface Handheld

VAZ-PK-1,5M-V1-G

Adapter cable module/hand-held programming device

| Ambient conditions | |
|---|---|
| Ambient temperature | -25 ... 60 °C (-13 ... 140 °F) |
| Storage temperature | -25 ... 85 °C (-13 ... 185 °F) |
| Relative humidity | 85 % , noncondensing |
| Climatic conditions | For indoor use only |
| Altitude | ≤ 2000 m above MSL |
| Pollution degree | 2 |
| Mechanical specifications | |
| Degree of protection | IP20 |
| Connection | removable terminals rated connection capacity: rigid/flexible (with and without wire-end ferrules): 0.25 mm ² ... 2.5 mm ² for multiple-wire connection with two wires of equal cross-section: flexible with twin wire-end ferrules: 0.5 mm ² ... 1.5 mm ² |
| Material | |
| Housing | PA 66-FR |
| Mass | 150 g |
| Mounting | DIN mounting rail |
| Tightening torque of clamping screws | 0.5 Nm ... 0.6 Nm |
| Compliance with standards and directives | |
| Directive conformity | |
| EMC Directive 2004/108/EC | EN 61000-6-2:2005, EN 61000-6-4:2007, EN 50295:1999 |
| Standard conformity | |
| Noise immunity | EN 61000-6-2:2005, EN 61326-1:2006, EN 50295:1999 |
| Emitted interference | EN 61000-6-4:2007 |
| Input | EN 61131-2:2004 |
| Degree of protection | EN 60529:2000 |
| Fieldbus standard | EN 50295:1999, IEC 62026-2:2006 |

Notes

Do not connect inputs and outputs, which are supplied via the module from AS-interface or via auxiliary power, with power supply and signal circuits with external potentials.