



CONNECT AND PROTECT

Surge Protection Solutions

nVent ERICO Critec Product Selection Guide



ERICO

NOTE: Product application information given in this document is of a general nature. Installers of the product are cautioned to ensure product is always installed in accordance with any applicable National Standards, Codes, and Practices.

Table of Content

The Need for Coordinated Protection.....	5
Six Point Plan of Protection.....	7
nVent ERICO Expertise	8
Certified Surge Protection Devices	9
Transient Discriminating Technology	10
The Core of TD Technology	11
Selection and Application of AC Power System SPDs (UL System)	12
Selection and Application of AC Power System SPDs.....	13
Data and Signal Line Protection.....	17
Products.....	20
Surge Protection Product Selection.....	22
SES40P	25
SES40	26
SES200.....	27
TDXM Modular Series.....	29
TDXC Compact Series	35
Rail Primary Power Surge Protector	38
Rail Primary Power Surge Protector With Flying Lead.....	39
Rail Secondary Power Surge Protector, AC Circuits	40
Rail Secondary Power Surge Protector, DC Circuits.....	41
DT and EDT SPD Features.....	42
DT1 Din Rail Surge Protection IEC Class I+II, 1+0 Mode	43
DT1 DIN Rail Surge Protection IEC Class I+II, 2+0 Mode.....	44
DT1 DIN Rail Surge Protection IEC Class I+II, 3+0 Mode	45
DT1 DIN Rail Surge Protection IEC Class I+II, 4+0 Mode	46
DT2 DIN Rail Surge Protection IEC Class II, 1+0 Mode	47
DT2 DIN Rail Surge Protection IEC Class II, 2+0 Mode	48
DT2 DIN Rail Surge Protection IEC Class II, 3+0 Mode.....	49
DT2 DIN Rail Surge Protection IEC Class II, 4+0 Mode.....	50
EDT2 Enhanced Din Rail Surge Protection IEC Class II, 1+0 Mode.....	51
EDT2 Enhanced DIN Rail Surge Protection IEC Class II, 2+0 Mode.....	52
EDT2 Enhanced DIN Rail Surge Protection IEC Class II, 3+0 Mode.....	53
EDT2 Enhanced DIN Rail Surge Protection IEC Class II, 4+0 Mode.....	54
PVT1 Photovoltaic Surge Protection Class I.....	55
PVT2 Photovoltaic Surge Protection Class II.....	56
Transient Discriminating Surge Diverter, 20 kA Three Mode.....	57
Surge Diverter, 24/48 DC	58
Transient Surge Filter	59
Surge Reduction Filter N-Series, Single Phase	60
Surge Reduction Filter N-Series, Three Phase.....	61
High Speed Data Line Protector.....	62

Table of Content

Subscriber Line Protector, Single Stage.....	63
Telephone Line Protector	64
Coaxial Surge Protector.....	65
Closed Circuit Television Protector	66
Community Antenna Protector, High Frequency.....	67
LAN Surge Protector	68
Data Equipment Protector.....	69
Universal Transient Barrier, Single Pair.....	70
Universal Transient Barrier, Dual Pair.....	71
Universal Transient Barrier, Single Pair Isolated Ground	72
Universal Transient Barrier, Modem/Telephone.....	73
nVent ERICO Protection Device, F-Series.....	74
nVent ERICO Protection Device, EPD100P Series	75
nVent ERICO Protection Device Kit.....	76
nVent ERICO Protection Device Replacement Module.....	77
nVent ERICO Protection Device Replacement Base	78
DIN Rail.....	78
Electronic Track Signal Protector	79
RTBN Rail Transient Barrier	80
Remote Transmitter Protector.....	81
Load Cell Protector	82
Surge Counter, Digital Display	83
Potential Equalization Clamp.....	84
MOV/GDT/SAD Tester MGATESTER1	85
Glossary of Terminology	86

The Need for Coordinated Protection



CRITICAL FACTORS

Critical factors need to be considered when determining the need for facility protection. Many factors can be determined by answering the following questions:

- What is the risk to personnel?
- What is the risk of equipment damage?
- What are the consequences of equipment failure?
- Is the equipment associated with an essential service?
- How will equipment failure affect overall facility operation and revenue generation?
- What are the legal implications of providing inadequate protection?

The statistical nature of lightning and the broad spectrum of energy delivered by a lightning flash, the problems created by various power generation and distribution systems, and the continued trend to more sensitive and specialized electronics, requires careful selection of available technologies if adequate protection is to be provided.

WHAT ARE THE COSTS OF INADEQUATE PROTECTION?

The costs that can result from inadequate protection are many and varied. The type of equipment within a facility will have a direct impact on the damage that can occur. Robust equipment, such as lighting and air-conditioning systems, are often able to withstand impulses as high as 1500 volts and are not as sensitive to the rapid rate-of-rise exhibited by the pre-clamped surge waveform as are electronics.

These systems are often not critical to the continuing operation of the site and therefore usually do not require the premium level of protection that is essential for more sensitive equipment.

However, significant damage can occur, even to the more robust systems, as a result of lightning induced surges resulting within a radius of several kilometers, or from switching induced surges. Costs can range from degradation of electrical or electronic systems to data loss, equipment destruction or injury to personnel. Some of these costs can appear relatively minor but the loss of an essential service or revenues associated with a facility or plant shut down can be enormous.

SOURCES OF TRANSIENTS AND SURGES

Although lightning is the most spectacular form of externally generated surges, it is only one source of over-voltage. Other sources include the switching of power circuits, the operation of electrical equipment by neighboring industries, the operation of

power factor correction devices, and the switching and clearing of faults on transmission lines. It is important to note that lightning does not need to directly strike a power line for such damage to occur; a strike several hundred meters away can induce large damaging transients, even to underground cables.

It is estimated that 70 to 85% of all transients are generated internally within one's own facility by the switching of electrical loads such as lights, heating systems, motors and the operation of office equipment.

Modern industry is highly reliant on electronic equipment and automation to increase productivity and safety. The economic benefits of such devices are well accepted. Computers are commonplace and microprocessor-based controllers are used in most manufacturing facilities. Microprocessors can also be found embedded in many industrial machines, security & fire alarms, time clocks and inventory tracking tools. Given the wide range of transient sources and the potential cost of disruption, the initial installed cost of surge

protection can readily be justified for any facility.

As a guide, the cost of protection should be approximately 10% of the cost of the facility's economic risk.

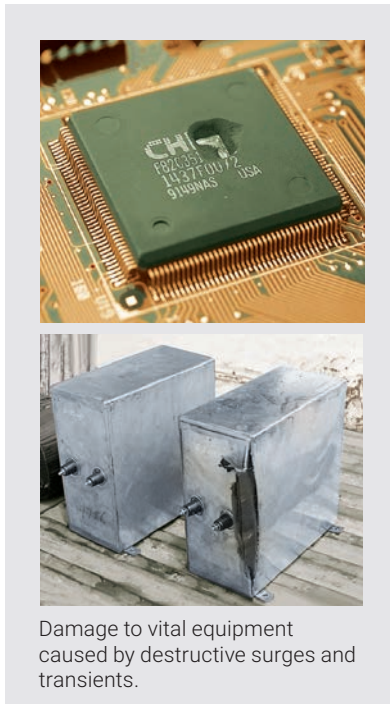

Damage to vital equipment caused by destructive surges and transients.

The Need for Coordinated Protection

Reliable protection of structures, industrial and commercial operations and personnel, demands a systematic and comprehensive approach to minimize the threats caused by transient over-voltages. Grounding, bonding, lightning protection and surge protection all need to be considered for comprehensive facility electrical protection. Each of these are interdependent disciplines that need a holistic design approach to ensure the facility is not left with a vulnerable "blind spot". The investment in surge protection can be wasted if "blind spots" exist. For example, installing a surge protection device on the power supply to a programmable logic controller is of little value if the I/O lines are not also protected. In addition, an air terminal on the facility may capture the lightning energy but without a dependable

ground system, this energy cannot be safely dissipated. Equally, even the most expensive Surge Protection Devices (SPDs) are poor performers if a low impedance equipotential ground is not provided. These interdependent disciplines are best applied when looking at a total facility rather than at an individual piece of equipment or portion of the facility.

It is for these reasons that nVent ERICO developed the Six Point Plan of Protection. The plan prompts the consideration of a coordinated approach to lightning protection, surge and transient protection and grounding, an approach that embraces all aspects of potential damage, from the more obvious direct strike to the more subtle mechanisms of differential earth potential rises and voltage induction at service entry points.

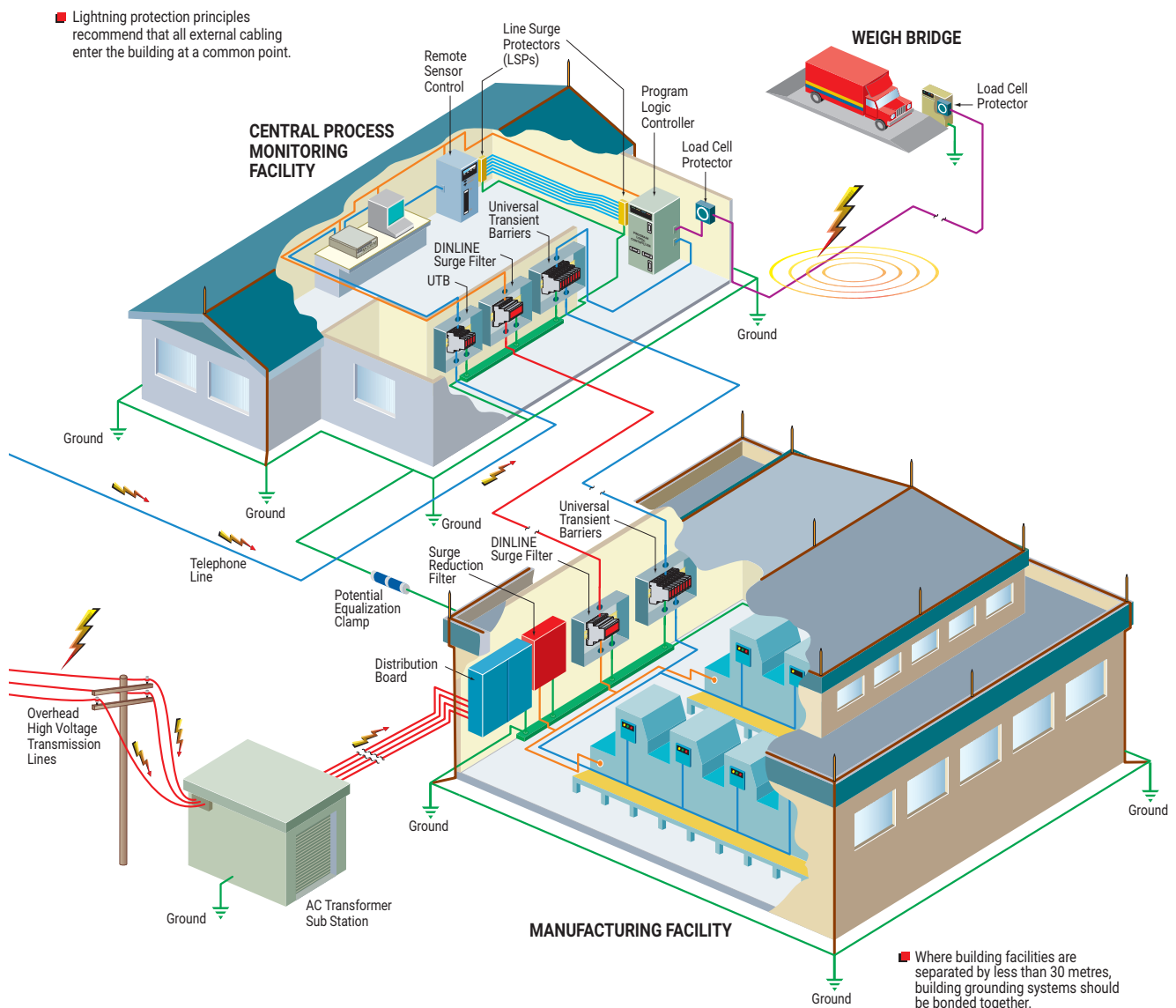

The Six Point Plan applied to a manufacturing facility. Surge and transient protection principles applied to a total facility rather than individual pieces of equipment.

Six Point Plan of Protection

By following the Six Point Plan of Protection, nVent ERICO customers are able to implement the most effective solutions to individual lightning, grounding and surge problems while retaining an integrated protection philosophy.

Point 5 of the Six Point Plan advocates protection of AC power services, advocating a coordinated approach to surge protection, where the first stage of defense is the installation of primary protection devices at the mains supply service entrance, followed by secondary protection at distribution branch panels and where necessary, at point-of-use applications.

Point 6 recognizes the need to provide effective surge protection on cables supplying telecommunications, signal and data management equipment.

The Six Point Plan of Protection from nVent ERICO

- 1 Capture the lightning strike.**
Capture the lightning strike to a known and preferred attachment point using a purpose-designed air terminal system.
- 2 Convey this energy to ground.**
Conduct the energy to the ground via a purpose-designed downconductor.
- 3 Dissipate energy into the grounding system.**
Dissipate energy into a low impedance grounding system.
- 4 Bond all ground points together.**
Bond all ground points to eliminate ground loops and create an equipotential plane.
- 5 Protect incoming AC power feeders.**
Protect equipment from surges and transients on incoming power lines to prevent equipment damage and costly operational downtime.
- 6 Protect low voltage data/telecommunications circuits.**
Protect equipment from surges and transients on incoming telecommunications and signal lines to prevent equipment damage and costly operational downtime.

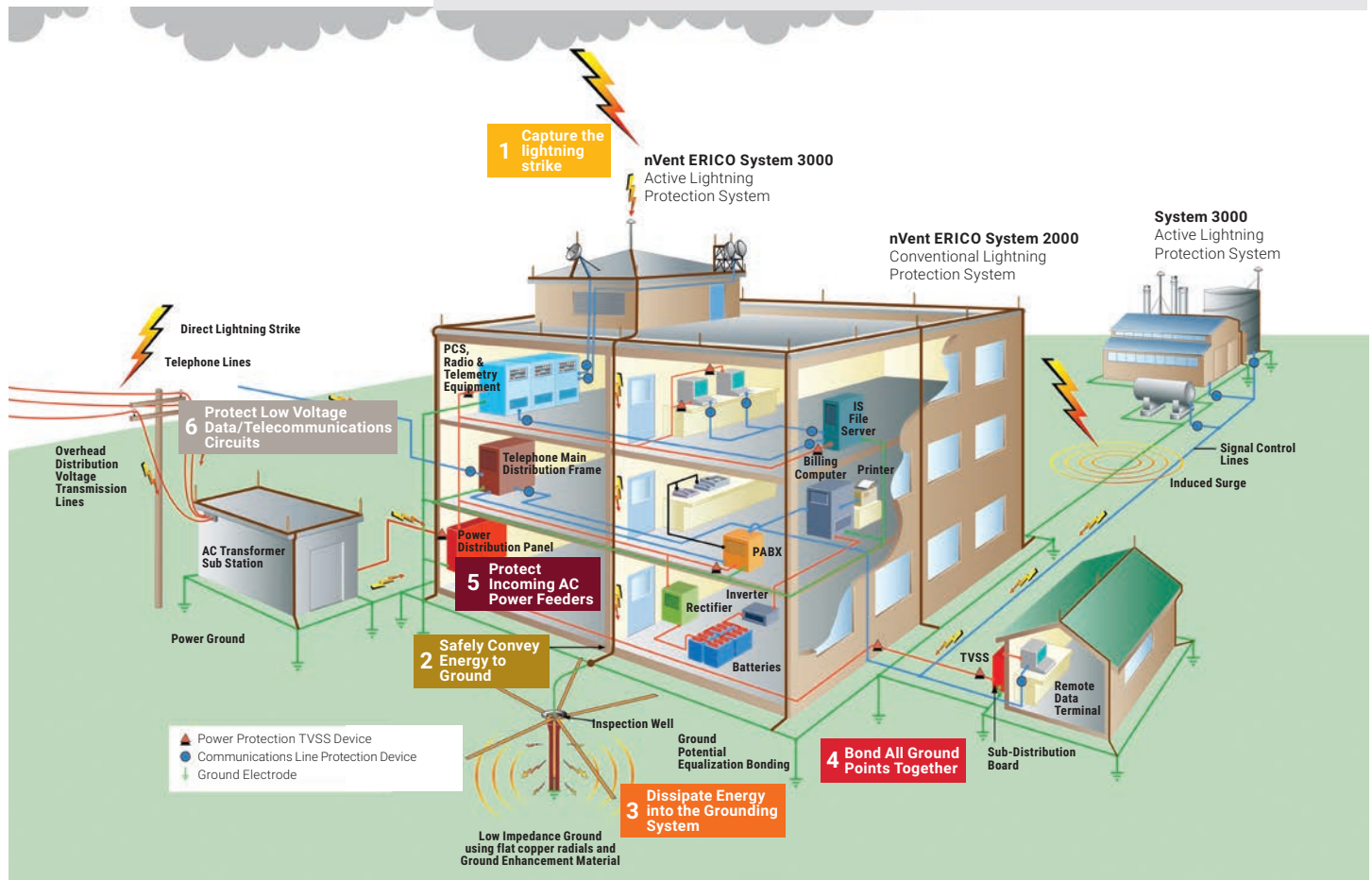

nVent ERICO Expertise

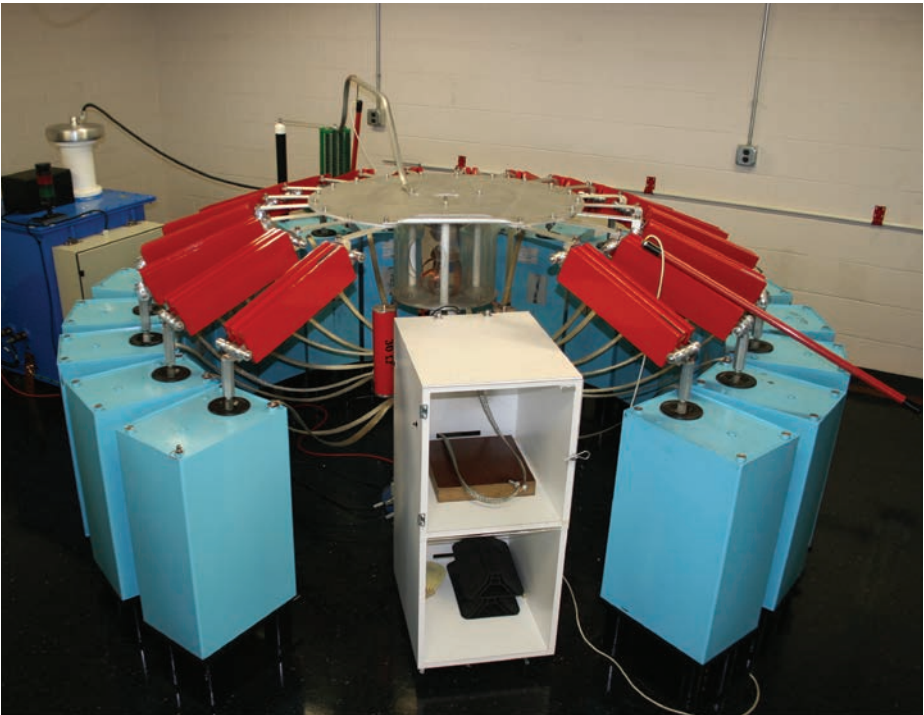

The nVent ERICO advantage is our approach to the complete Facility Electrical Protection Solution. Well designed and high quality Surge Protection is critical to a facility equipment's reliable operation, however it is only part of the solution.

nVent ERICO therefore offers the complete range and expertise in grounding, bonding, surge and lightning protection, providing the complete solution worldwide and across applications including Commercial, Industrial, Telecom, Utility and Railway. Our service and expertise encompasses more than just the product.

PRODUCT TESTING

To effectively meet market requirements and ensure our products are designed and tested to the highest of performance standards, nVent ERICO has invested in state of the art testing equipment that is able to:

- Support application testing for clients – to ensure your equipment is adequately protected.
- Participate in the UL Client Test Data Program.
- Support competitive product testing.
- Test and evaluate to a range of mechanical, electrical and environmental requirements.

HISTORY

nVent ERICO continues to be a pioneer in the low voltage Surge Protection industry, having been involved in grounding and bonding applications for over 100 years, and as a manufacturer of SPDs for over thirty years.

Our involvement in the industry predates the creation of the initial IEC and UL low voltage surge protection standards. We've been on the journey since the early days of Low Voltage AC surge protection, with the issuing of the IEEE587 standard in 1980, and we have been active on all major worldwide SPD standards committees and industry bodies (including IEEE, IEC, and UL) since.



SEMINARS AND SITE AUDITS

Each year nVent ERICO conducts hundreds of seminars in numerous countries around the world, educating specifiers, engineers, and installers on Facility Electrical Protection, of which surge protection plays a key role.

Certified Surge Protection Devices



nVent ERICO surge protective devices (SPDs) provide the option for traditional construction or TD technology. For example, the DT product line features traditional construction, while the EDT product line features with TD technology. These product lines have been designed and independently tested and certified to the latest editions of both IEC61643-11 and UL1449 Ed. 4

This provides the user of the product peace of mind that the products will perform safely in application, and also perform to the claimed ratings provided. Both these standards have stringent tests that are not easy to pass, but essential to ensure the product is designed well for safe behavior, and for effective protection performance to the product ratings.

Compliance to these standards are required by code in many countries, however still many countries around the world do not require compliance, leaving those countries vulnerable to poorly performing products.

An informed buyer will avoid non-compliant product, instead demanding compliance to one or both of these standards, factually verified by an independent third party test laboratory certificate. Compliance to these standards alone however should be considered a benchmark or minimum



requirement, as there are certain enhanced performance requirements that may be advantageous for some applications.

One example of this is how the SPD performs during an AC overvoltage event. In both standards referenced above,

the requirement is for the SPD to safely disconnect from service during these events, however a better solution is for the SPD to survive such an event, thereby continuing to provide protection to your valuable equipment being protected.

nVent ERICO's TD technology delivers just that, a true step-up in performance for SPDs. Our SPDs with TD technology have been designed to be unaffected by the AC overvoltages applied during testing, while not compromising the clamping performance. This provides them with the ability to survive extreme overvoltage conditions and still be operational afterwards to protect your valuable equipment from subsequent surges and transients.

This extends greatly the life expectancy of the SPD within the most extreme environments, saving maintenance work and reducing operational downtime.

Transient Discriminating Technology

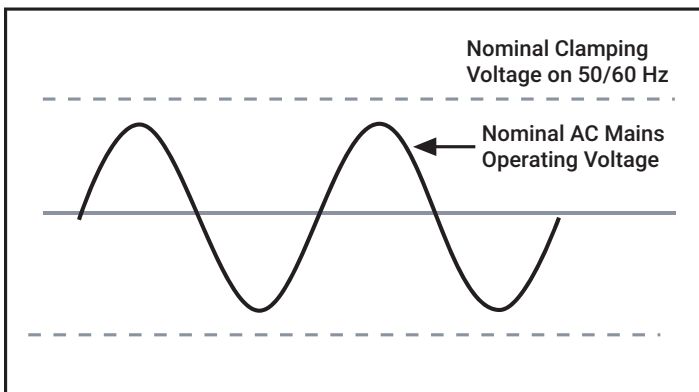

To meet the fundamental requirements of performance, longer service life and greater safety under real world conditions, nVent ERICO has developed Transient Discriminating (TD) Technology.

This quantum leap in technology adds a level of “intelligence” to the Surge Protection Device enabling it to discriminate between sustained abnormal overvoltage conditions (Temporary Over Voltages – TOVs) and true transient or surge events. Not only does this help ensure safe operation under practical application, but it also prolongs the life of the protector since permanent disconnects are not required as a means of achieving internal over-voltage protection.

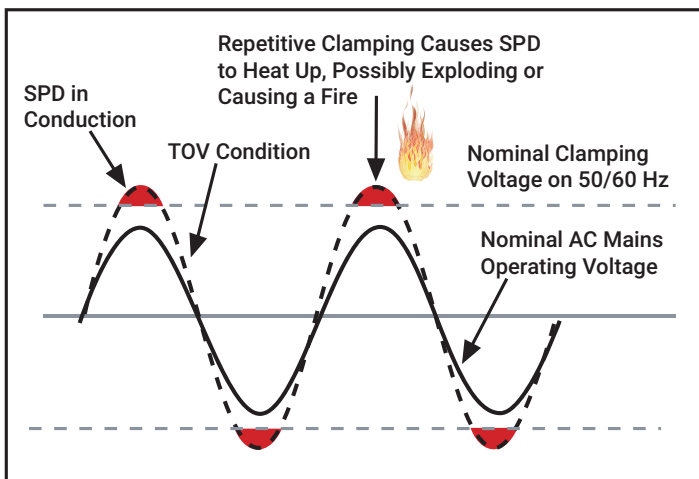

TRADITIONAL TECHNOLOGIES

Conventional SPD technologies utilizing metal oxide varistors and/or silicon avalanche diodes to clamp or limit transient events are susceptible to sustained 50/60 Hz mains over-voltage conditions (TOVs) which often occur during faults to the utility system. Such occurrences present a significant safety hazard when the suppression device attempts to clamp the peak of each half cycle on the mains overvoltage.

This condition can cause the device to rapidly accumulate heat and in turn fail with the possibility of inducing a fire hazard. The diagram shows how a traditional SPD is chosen to have a nominal clamping voltage that is above the peak of the nominal AC mains voltage. However, in the lower diagram, it can be seen that when the AC mains experiences a Temporary Over-Voltage (TOV), the SPD attempts to clamp the over-voltage, and rapidly heats up, resulting in failure, potentially accompanied by fire or explosion.

The Core of TD Technology



The secret to nVent ERICO's Transient Discriminating Technology is its active frequency discrimination circuit. This patented device can discriminate between a temporary over-voltage (TOV) condition and a very fast transient, which is associated with lightning or switching-induced surges. When the transient frequencies are detected, the patented Quick-Switch within TD activates to allow the robust protection to limit the incoming transient. The frequency discriminating circuit that controls the Quick-Switch helps ensure that the SPD device is immune to the effects of a sustained 50 or 60 Hz TOV. This allows the device to keep operating, in order to help provide safe and reliable transient protection, even after an abnormal over-voltage condition has occurred.

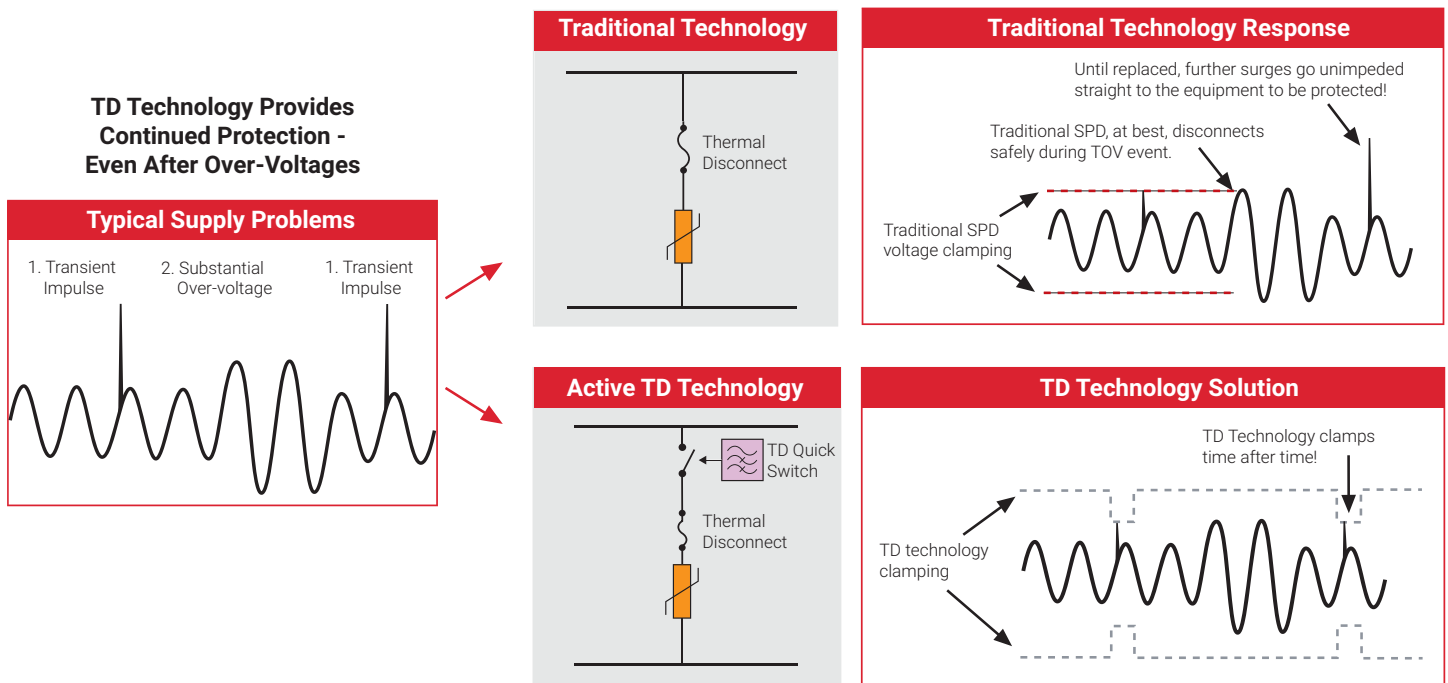

Effectively, TD Technology allows the SPD to have two clamping levels – one well above the peak of a TOV (up to twice its nominal AC voltage!), and the other much lower, to effectively and swiftly clamp lightning transients.

As the explanatory illustration shows, this allows the TD circuit to still remain operational after TOV events, thus continuing to clamp transients and providing a much longer operational life. For example, the IEC 61643-11 standard applies a test of 442 Vac for two hours from Line to Neutral for SPDs intended to operate at 230 Vac. While most SPDs fail safely during this test, nVent ERICO's EDT2 Series SPDs are unaffected by this stringent test, and remain completely operational. The IEC 61643-11 standard calls this Withstand mode, as opposed to Safe Failure mode.

nVent ERICO SPDs that incorporate TD Technology are especially recommended for any site where sustained over-voltages are known to occur, and where failure of traditional SPD technologies cannot be tolerated.

Selection and Application of AC Power System SPDs (UL System)

RECOMMENDED SURGE RATINGS (8/20µs)

ANSI/IEEE C62.41			CAT C	CAT B	CAT A
IEC 61643 Test Class	I		I, II	II	III
VDE Classification	A		B	C	D
	POINT-OF-ENTRY HIGHLY EXPOSED OR CRITICALLY IMPORTANT SITES	POINT-OF-ENTRY EXPOSED OR RURAL SITES	POINT-OF-ENTRY INNER CITY SITES	SUB CIRCUITS OR NEAR TO POINT-OF-ENTRY	DISTRIBUTED CIRCUITS, POWER OUTLETS, CIRCUITS REMOTE FROM POINT-OF-ENTRY
EXPOSURE					
HIGH Ng >2	100kA	70kA	40kA	20kA	10kA
MED. Ng 0.5-2	65kA	40kA	20kA	20kA	5kA
LOW Ng <0.5	65kA	40kA	15kA	5kA	3kA

Ng = strikes/km²/year.

RECOMMENDED PRODUCTS	
PRODUCT SERIES	SRF N SERIES
	TDX 50, 100, 200, 300, 400
	SES40P SERIES
	DT1 SERIES
	DT2/EDT2 SERIES
	TSF Series
	TDS1301 Series

"TYPE" OF SPD

In the UL system, SPDs are tested to various Types, intended to assess and assure their suitability for use in different locations and circumstances. The Type of SPD indicates its suitability for use in certain areas of a facility (service entrance, Branch Panel, etc.). Because of this, the battery of tests that the SPD are subject to will be more or less severe, in descending order of Type.

The SPD Types are as follows:

Type 1 – Permanently connected SPDs, intended for installation between the secondary of the service transformer and the line side of the service equipment overcurrent device, as well as the load side, including Molded Case SPDs intended to be installed without an external overcurrent protective device.

Type 2 – Permanently connected SPDs intended for installation on the load side of the service equipment overcurrent device; including SPDs located at the branch panel and Molded Case SPDs.

Type 3 – Point of utilization SPDs, installed at a minimum conductor length of 30 feet (10 meters) from the electrical service panel to the point of utilization, for example cord connected, direct plug-in, receptacle type and SPDs installed at the utilization equipment being protected.

Type 4 Component Assemblies – Component assembly consisting of one or more Type 5 components together with a disconnect (integral or external) or a means of complying with the limited current tests.

Type 1, 2, 3 Component Assemblies – Consists of a Type 4 component assembly with internal or external short circuit protection.

Type 5 – Discrete component surge suppressors, such as MOVs that may be mounted on a PWB, connected by its leads or provided within an enclosure with mounting means and wiring terminations.

Fitting SPDs at all three locations may not be necessary, depending on the building size, and wiring length. Generally, SPDs are always fitted at the point of entry (Service Entrance), and in smaller equipment rooms may just be, additionally, at the equipment. In larger buildings, spread over multiple floors or large areas, SPDs should also be provided at the Branch Panels, and additionally at sensitive or critical equipment.

SPDs are primarily rated according to how large a surge current magnitude they can handle, and how well they limit the voltage while conducting that surge current. These parameters are

Selection and Application of AC Power System SPDs

Having determined the Class of SPD required, the correct voltage and configuration needs to be determined. The standard IEC 60364-1 details the following system configurations. In the descriptions that follow, U_0 is used for the nominal systems voltage, and U_c is used for the maximum continuous operating voltage (this is a parameter of an SPD).

TN-C System

In this system, the neutral and protective earth conductor are combined in a single conductor throughout the system. This conductor is referred to as a PEN, a "Protective Earth & Neutral". All exposed conductive equipment parts are connected to the PEN.

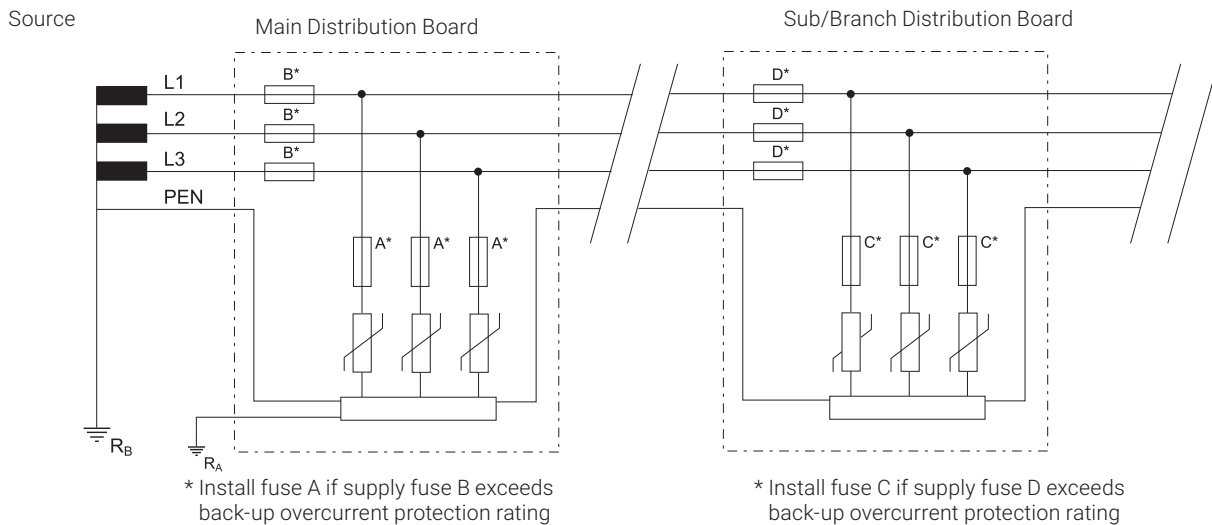

SPDs Installed	Description	Example Product
Phase to PEN (*3+0*)	At least $1.1 \times U_0$	DT230030R

For example, on a 230 V Ph-N system, Ph-PEN protection should have a U_c rating of at least 255 V. Generally an SPD with a U_c rating of at least 275 V would be selected for 220 to 240 V systems. Often, to allow for power supply voltage fluctuations, a U_c of at least $1.3 \times U_0$ is recommended, such as a U_c of 300 V for a 230 V system, or nVent ERICO's TD technology would be chosen.

TN-S System

In this system, a separate neutral and protective earth conductor are run throughout. The Protective Earth (PE) conductor is normally a separate conductor, but can also be the metallic sheath of the power cable. All exposed conductive equipment parts are connected to the PE conductor.

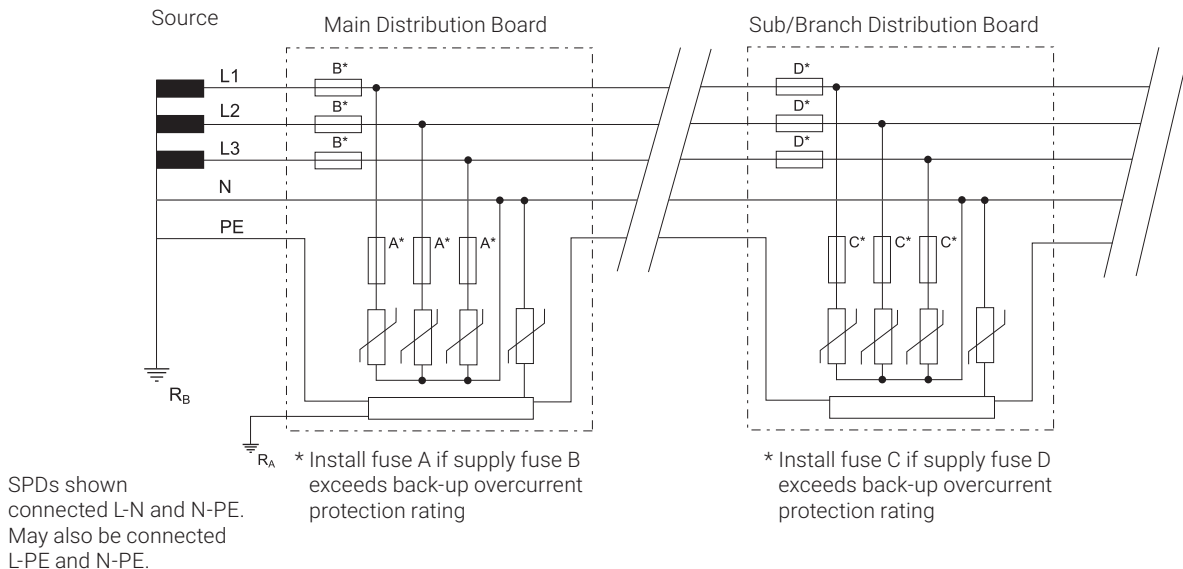

Selection and Application of AC Power System SPDs

SPDs Installed	Description	Example Product
Phase to PE ("4+0"), or Phase-N, and N-PE ("3+1")	At least 1.1 x Uoc	DT230040R DT230031R

For example, on a 230 V Ph-N system, Ph-PE (or Ph-N) protection should have a Uc rating of at least 255 V. Generally an SPD with a Uc rating of at least 275 V would be selected for 220 to 240 V systems. Often, to allow for power supply voltage fluctuations, a Uc of at least 1.3 x Uo is recommended, such as a Uc of 300 V for a 230 V system, or nVent ERICO's TD technology would be chosen.

TN-C-S System

In this system, the supply is configured as per TN-C, while the downstream installation is configured as per TN-S. The combined PEN conductor typically occurs between the substation and the entry point into the building, and earth and neutral are separated in the Main Distribution Board. This system is also known as Protective Multiple Earthing (PME) or Multiple Earthed Neutral (MEN).

The supply PEN conductor is earthed at a number of points throughout the network and generally as close to the consumer's point-of-entry as possible.

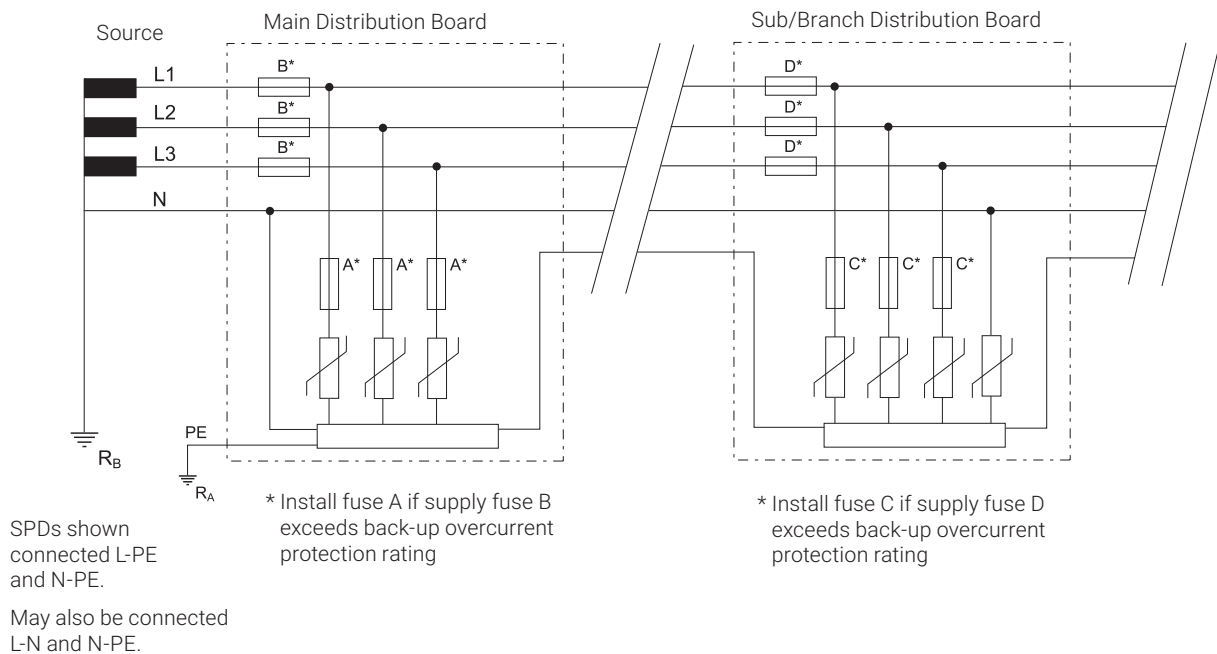

SPDs Installed	Description	Example Product
MDB: Phase to PEN ("3+0")		
DB: Phase to PEN ("4+0"), or Phase-N, and N-PE ("3+1")	At least 1.1 x Uo	DT130030R, DT230040R, DT230031R

For example, on a 230 V Ph-N system, Ph-PE (or Ph-N) protection should have a Uc rating of at least 255 V. Generally an SPD with a Uc rating of at least 275 V would be selected for 220 to 240 V systems. Often, to allow for power supply voltage fluctuations, a Uc of at least 1.3 x Uo is recommended, such as a Uc of 300 V for a 230 V system, or nVent ERICO's TD technology would be chosen.

Selection and Application of AC Power System SPDs

TT SYSTEM

A system having one point of the source of energy earthed and the exposed conductive parts of the installation connected to independent earthed electrodes. The incoming supply neutral is not earthed at the main distribution board.

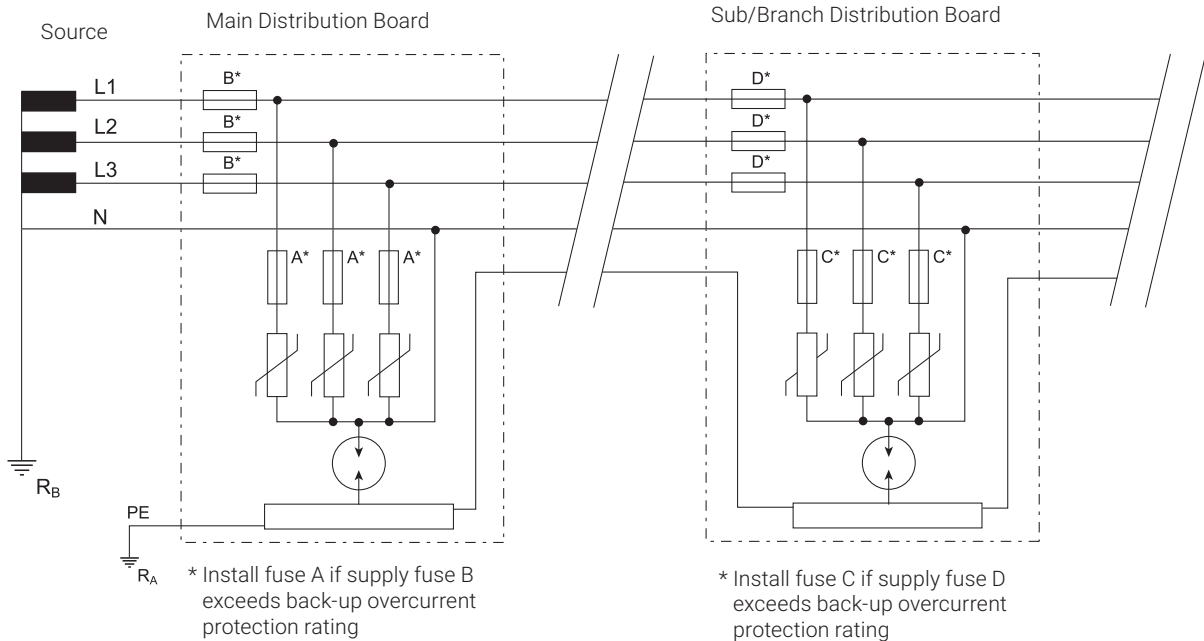

SPDs Installed	Description	Example Product
Phase to N, N-PE ("3+1")	At least 1.1 x Uoc	DT130031R, DT230031R

For example, on a 230 V Ph-N system, Ph-N protection should have a Uc rating of at least 255 V. Generally an SPD with a Uc rating of at least 275 V would be selected for 220 to 240 V systems. Often, to allow for power supply voltage fluctuations, a Uc of at least 1.3 x Uo is recommended, such as a Uc of 300 V for a 230V system, or nVent ERICO's TD technology would be chosen.

In the TT system, in order for overcurrent protective devices (fuses and circuit breakers) to operate in the intended manner, it is important that SPDs must not connect directly from phase to protective ground, but from phase to neutral and neutral to ground. Therefore, the Neutral-to-PE SPD carries both the PE to neutral impulse current and the PE to phase impulse currents. This SPD is recommended to be a GDT (Gas Discharge Tube) due to their generally superior energy handling characteristics.

Selection and Application of AC Power System SPDs

IT SYSTEM

A system having no direct connection between live parts and earth, but all exposed conductive parts of the installation being connected to independent earthed electrodes. The source is either floating or earthed through a high impedance (to limit fault currents). This means that during a Phase to Earth fault, the systems continues to operate. This is detected, and maintenance efforts commenced to rectify the fault. However, during this time, the Phase to Earth voltage rises to the usual Line to Line voltage, and installed SPDs must withstand this during this time. Most installed IT systems do not utilise a neutral conductor - equipment is powered from line to line. The IT system is typically used in older installations in countries such as Norway and France. It is also used in special applications, such as intensive care wards of hospitals and special industrial applications.

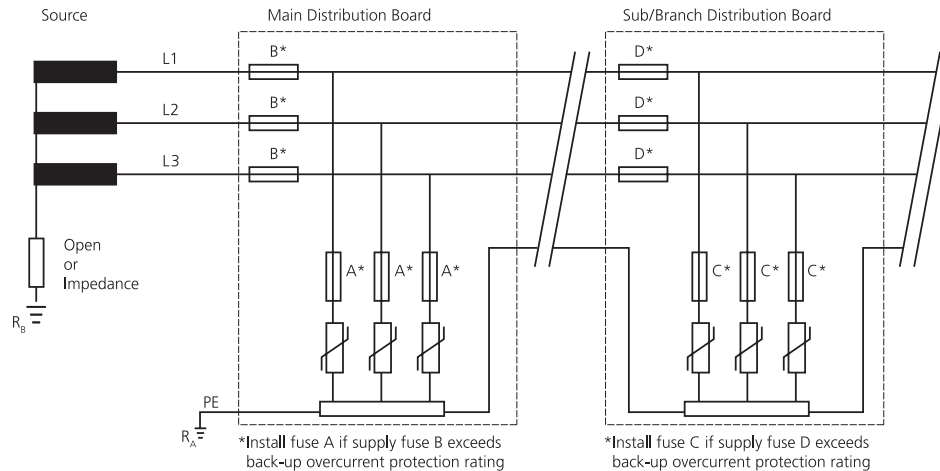

SPDs Installed	Description	Example Product
Phase to PEN ("3+0")	At least 1.73 x Uo	DT230030R

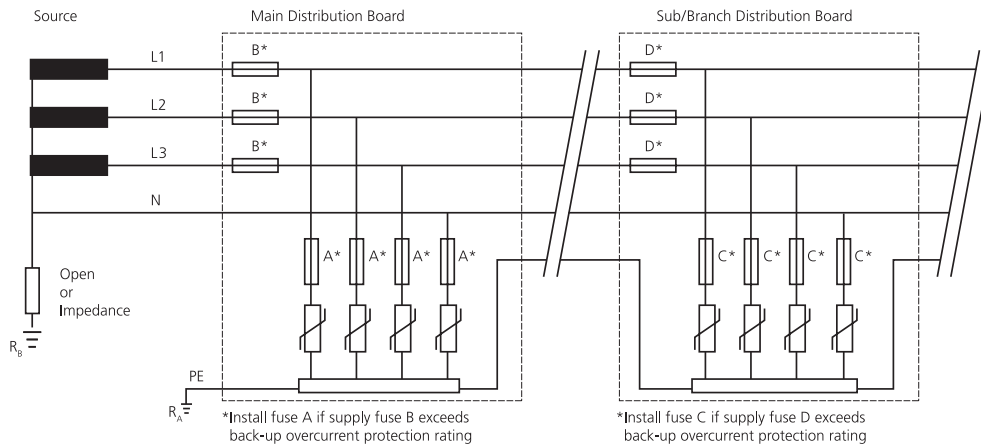

SPDs Installed	Description	Example Product
Phase to PEN ("4+0")	At least 1.73 x Uo	DT130040R, DT230040R

For example, on a 230 V Ph-N system, Ph-PE and N-PE protection should have a Uc rating of 440 V (allowing for the L-L voltage and a 10% tolerance). Often an additional safety margin is applied, to allow for instabilities that can occur in the ungrounded IT system, such as a Uc of 480 V.

Data and Signal Line Protection

HOW TO SELECT SURGE PROTECTION FOR DATA, SIGNALLING AND CONTROL CIRCUITS

Knowing where to install surge protection can be difficult. To ensure cost-effective protection is provided for data, signalling and control circuits, two issues need to be considered:

- Where should the SPDs be installed?
- What type of SPD is appropriate for each circuit type and location?

WHERE SHOULD THE SPD(S) BE INSTALLED?

Communications devices are at risk from transients being induced onto the interconnecting signal lines. The use of surge protection barriers, installed at either end of the lines, provides cost effective protection. Communication or signal lines that enter or exit the building pose the highest risk. In such circumstances, protection devices should be installed at the point-of-entry or at the equipment termination itself. Internal wiring which extends more than 10 to 15m should also be protected. Twisting or shielding of cables provides a level of protection, however this should not be regarded as sufficient for the sensitive interfaces that characterize today's communication devices.

HOW TO SELECT AN SPD FOR A GIVEN LOCATION

Five parameters must be considered to ensure that surge protection devices for use on data, signalling or control circuits are effective and do not adversely affect operation of the circuit.

1. SPDs are designed to clamp the excess transient voltage to safe levels sustainable by the equipment, yet should not interfere with the normal signalling voltages. As a guide, the SPD clamping voltage should be selected to be approximately 20% higher than peak working voltage of the circuit.
2. The line current rating of the SPD should be sufficient to handle the maximum expected signalling current.
3. The SPD bandwidth should be sufficient to allow correct operation of the system without adverse attenuation. This ensures that the attenuation of the SPD at the nominal operating frequency of the system does not exceed the stated limit. For most SPDs, frequency attenuation data or a maximum recommended baud rate is generally specified.
4. The connection termination, mounting method, number of lines to be protected and other physical aspects must be considered.
5. The SPD surge rating should be appropriate for the intended location. For circuits internal to the building, surge ratings of 1-5kA are generally sufficient. For the protection of circuits that connect to exposed lines entering or exiting the facility, 10-20kA is recommended. Alternatively a protocol or standard may be specified that defines the above parameters. All UTB products are rated 20kA for higher exposure areas.

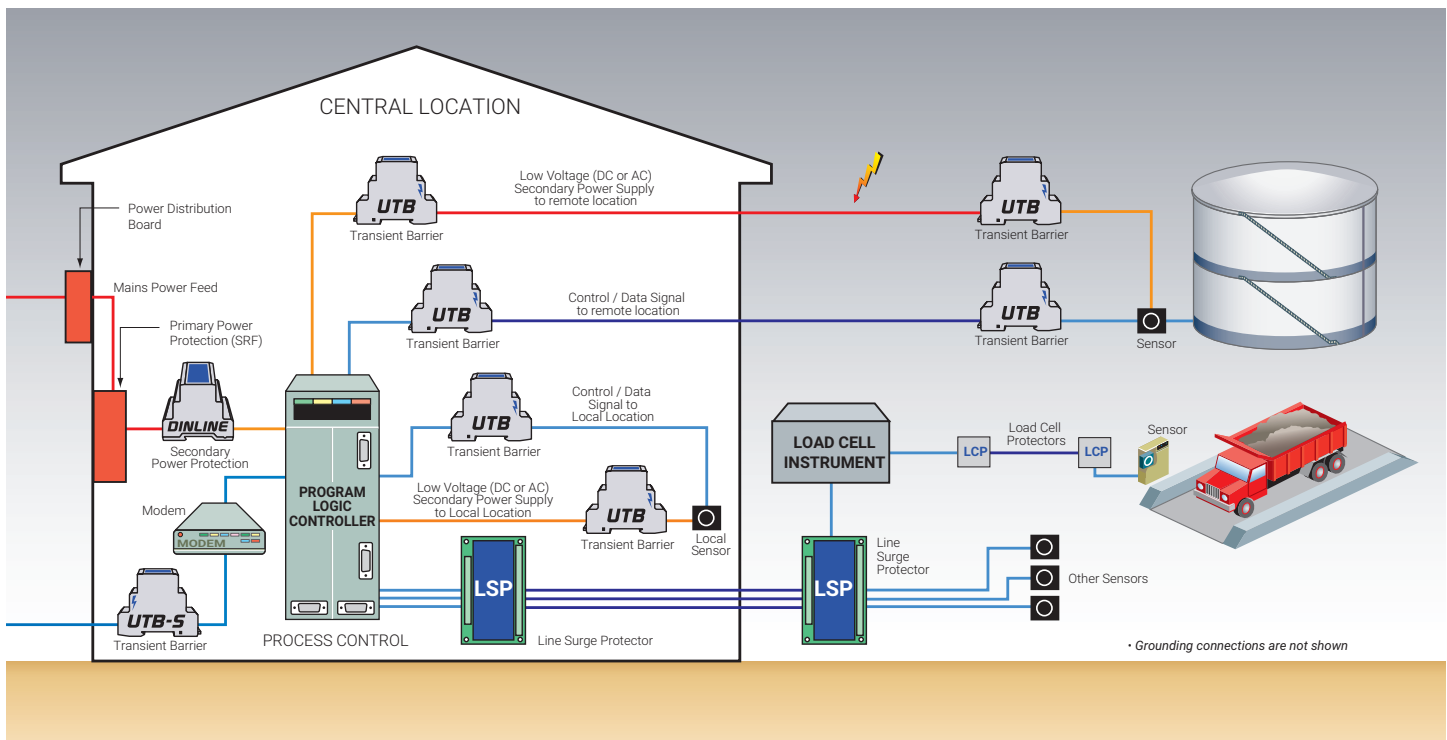

Data and Signal Line Protection

SAMPLE APPLICATIONS

2-Wire Isolated Ground Transducers/Sensors

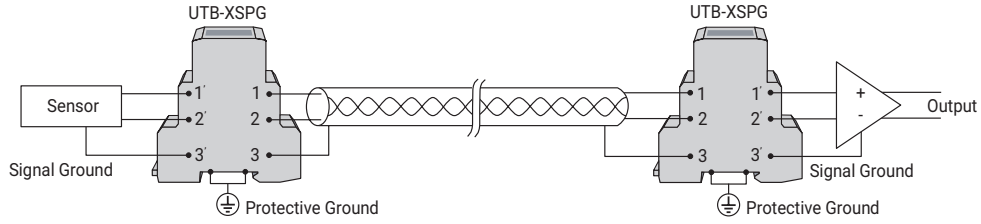

2-Wire Sensors

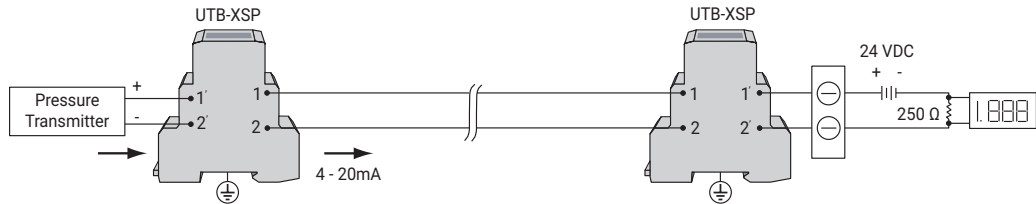

Powered Sensor Protection

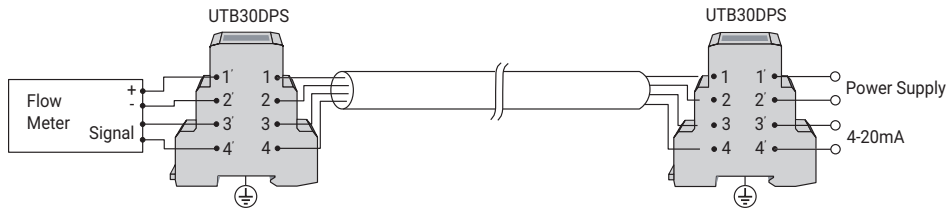

Multiple Sensor or up to 4-Wire Sensor

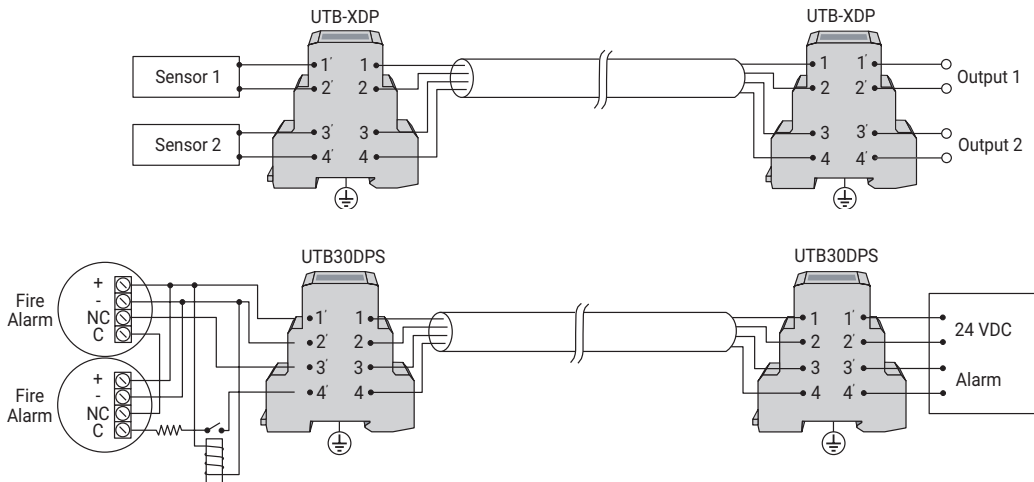

Protecting Sensors in Hazardous Locations

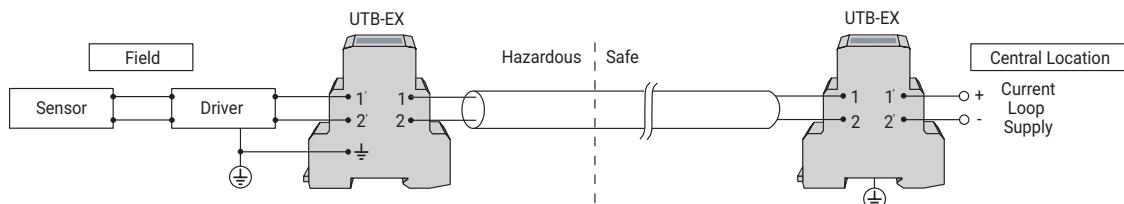

Data and Signal Line Protection

GUIDE TO DATA AND SIGNALING CIRCUITS

The selection of an SPD for communication and signalling circuits requires knowledge of the:

1. Maximum Continuous Operating Voltage (U_c)
2. Maximum line current (I_L)
3. Frequency
4. Termination (connector type and/or impedance)

Where a protocol is known, this often eliminates the need to verify product selection criteria 1-3, and occasionally 4.

A number of different SPDs often meet the requirements as defined by the protocol, so the final choice of which SPD to use is often determined by its type of physical connection, number of lines to be protected, or its surge rating. Some protocols do not define the actual connector or pin configuration, and in some cases, not all lines defined by the protocol will be used. Please refer to the documentation provided with the equipment requiring protection to ensure the proposed protection modes are adequate and that the SPD's characteristics will not interfere with normal system operation.

Protocol/Standard	Description	Applicable SPD Series
RS-232 (V.24)	Unbalanced, bi-directional communication circuit. Although standard allows +/- 25 V signaling, use of more than +/- 12 V is uncommon	UTB 15 SP ⁽¹⁾ , UTB 15DP ⁽²⁾ UTB 5 ⁽¹⁾
RS-422 (V.11)	Industrial version of RS-232. 0-5 V balanced signaling	UTB 5 ⁽¹⁾
RS-423	Similar to RS-232 but +/- 5 V signaling used	UTB 5 ⁽¹⁾
RS-485	Similar to RS-422 but allows multiple devices to communicate. DB-9 connector is common	UTB 5 ⁽¹⁾
Ethernet	Ethernet is the term used to describe a family of communication protocols.	LANRJ45C6P
Cat 4	* 10BaseT is a 10 MHz system using twisted pair of coax cables	
Cat 5	* 100BaseT is a 100 MHz system using twisted pair cables	
Cat 6	* 10GBaseT is a 250 MHz system using twisted pair cables	
10BaseT	Cat 4 is a cable specification that allows operation up to 10BaseT, while Cat 5 allows operation up to 100BaseT frequencies.	
100BaseT		
PoE	Power Over Ethernet	
Telephone Lines		UTB SA ⁽²⁾ , UTB TA ⁽²⁾
4-20 mA current loop (with HART)	Common industrial communications protocol used to interface with transducers etc	UTB xDP, UTB 30DPS, UTB xSP
Binary Signals		UTB xSP ⁽¹⁾ , UTB xDP ⁽¹⁾
Bitbus (IEEE 1118)	Digital communications network based on RS-485 and SDLC allowing communication between PLCs and controllers	UTB 5 ⁽¹⁾
CAN-Bus (data signal line)	Differential serial communications protocol defined in ISO 11898 standard	
DeviceNet (data signal line)	Communication protocol used to connect industrial devices such as limit switches, motor starters to PLCs and controllers	
M-Bus	Communication protocol for networking and remote reading of heat, gas, water, and energy meters	UTB 60 ⁽¹⁾
Ex (I) - HART, 4-20 mA circuit, measurement circuits	Hazardous locations	UTB15 Ex, UTB30 Ex
Profibus - PA	Process field bus - process automation. Ideal for explosion - hazardous areas	UTB30 Ex
Strain gauge / Load cells	As used in weigh bridges etc.	LCP01A
ASDL	Asymmetric Digital Subscriber Line. Protocol for data communication over copper telephone lines. Uses single copper wire pair.	UTB TA ⁽²⁾ , UTIntegrated Service Digital Network. Protocol for voice and data over copper telephone lines
HDSL	High bit rate Digital Subscriber Line. Protocol for data communication over copper telephone lines. Uses two copper wire pairs.	B SA ⁽²⁾
ISDN	Integrated Service Digital Network. Protocol for voice and data over copper telephone lines	

1. The number of UTB's required is dependent on the number of wires being used in the signalling circuit. UTBs are designed for balanced circuits and each UTB will protect one pair of wires. The UTB can also be used to protect two unbalanced circuits.
2. The UBT TA is rated to 500 A 8/20 us and intended to meet US NEC requirements. The UTB SA are rated to 20 kA 8/20 μs and specifically designed and approved for use on the Australian telecommunication network.

Products

AC POWER SURGE PROTECTION

DT1

The DIN Rail mounted DT1 family of SPDs provide reliable and efficient protection against voltage transients within the IEC Class I & II environments and is certified to UL Type 1 CA. Tested and independently certified to the IEC (via VDE) and UL standards, the DT1 Series provides a range of safety and performance features for the harshest environments and suitable for protection within a wide range of applications.

DT2

The DIN Rail mounted DT2 family provides many of the same benefits as the DT1 Series but is specifically designed to fit within the parameters of IEC Class II environments and is certified to UL Type 1 CA. Targeting the Class II / Type 1 CA classification allows the system designer to effectively select the correct coordinated protection while keeping total project costs in check.

EDT2

The DIN Rail mounted EDT2 family of SPDs provide reliable protection against voltage transients within the IEC Class II environments and is certified to UL Type 1 CA. In addition, nVent ERICO's Transient Discriminating (TD) technology ensures continued operation during and after sustained and abnormal over-voltage events. Tested and independently certified to the IEC (via VDE) and UL standards, the EDT2 Series provides a range of safety and performance features for the harshest environments and suitable for protection within a wide range of applications. The EDT2 Series provides extended service life in the harshest of environments, ensuring your equipment and systems are kept safe and operational through extreme abnormal voltage conditions.

TDX Modular

nVent ERICO's line of Transient Discriminating Panel Protectors are designed for critical protection applications. This line is specifically designed for equipment, panel and motor protection applications and to provide long life, even under the most adverse over-voltage conditions. All products are listed to CE, UL 1449 Ed. 4. Some of the features include: replaceable modules, TD Technology for Temporary Overvoltage protection, thermal protection, short circuit current cartridge fusing, compact enclosures, voltage presence LEDs, status indication flag per mode, audible alarm, surge counter, filter, and voltage free contacts.

TDX Compact

nVent ERICO's line of Transient Discriminating Panel Protectors are designed for critical protection applications. This line is specifically designed for equipment, panel and motor protection applications and to provide long life, even under the most adverse over-voltage conditions. All products are listed to CE, UL 1449 Ed. 4 to Type 1 and Type 2 locations. Some of the features include; TD Technology for Temporary Overvoltage protection, thermal protection, short circuit current cartridge fusing, compact enclosures, voltage presence LEDs, audible alarm, and voltage free contacts.



Products

AC POWER SURGE PROTECTION



SES40P

The nVent ERICO SES40P Series of Surge Protective Devices (SPD) provide economical protection against damaging transients and surge events. These Type 1 devices are UL Listed to UL 1449 Edition 4 and cUL Listed to CAN/CSA C233.1. This allows installations on the line or load side (Type 1 or Type 2) of the service panel in accordance with the NEC 2014 or CAN/CSA C233.1 without the requirement for additional circuit breakers or fuses. Primary applications are service entrance, branch, commercial, industrial, and residential. Other applications include OEM panels, solar combiner boxes, UL 96A lightning protection installations and light pole applications. The housing is constructed of UV-stabilized thermoplastic and meets the UL 50 Type 4X rating, making it ideal for both indoor and outdoor applications. All of the models have a 20kA nominal discharge current rating, the highest level recognized under the UL 1449 Edition 4 standard.

SURGE FILTERS



SRF

The SRF (Surge Reduction Filters) product family combines high-energy surge diversion with surge filtering, making them ideal for primary service protection applications. Their efficient low pass filtering stage dramatically reduces the rate-of-voltage rise and the let-through voltage thereby substantially reducing the risk of physical equipment damage. They incorporate TD technology making them robust against AC power system temporary overvoltages, and their standards compliance to IEC 61643-11 Class I & Class II ensure maximum product performance with maximum product safety.

TSF

The Transient Surge Filter (TSF) product family combines nVent ERICO's Transient Discriminating (TD) technology with a low pass filter to protect against transient events and attenuate small signal RFI/EMI noise problems. Perfect for PLC controllers, SCADA systems, motor control centers, and other similar applications, the TSF also features serviceable surge modules and a compact form factor. The TSF range of products are certified to UL 1449 4th Edition, UL 1283 5th Edition (EMI Filtering), and IEC 61643-11 Class II.

DATA / SIGNAL PROTECTION





Lightning or induced surges can destroy or compromise signal communications systems and data. nVent ERICO offers multiple series of data and signal surge protection devices designed to provide transient protection for equipment from induced surges. These are also well-suited to the protection of industrial equipment and are compact in size, while offering high surge carrying capacity. nVent ERICO data and signal surge protection offers a complete solution to eliminate damage, downtime, and power disruption..

Surge Protection Product Selection

The various product solutions available are listed below. The basic division is into power protection and signal protection. Power protectors are further divided into shunt protection and series (filtering) protection. Signal protectors are generally divided by connectors types and application.

Power Protection – Non-Dinrail Type 1

Shunt protection for Power Circuits

<p>TDX YYY V ZZZ</p> 	<p>TDX = PRODUCT FAMILY</p>	<p>YYY = SURGE RATING 50 KA 100 KA 200 KA 300 KA 400 KA</p>	<p>V = PRODUCT VERSION M = MODULAR S = MODULAR WITH SURGE COUNTER & FILTER (100KA & 200KA) C = COMPACT</p>	<p>ZZZ = VOLTAGE CONFIGURATION 120 120/208 120/240 120/240D 240 240D 277/480 277/480TT 347/600 480D</p>
<p>SES40P XXX YY</p> 	<p>SES = PRODUCT FAMILY</p>	<p>XXXX = VOLTAGE CONFIGURATION 120 120/240 208 240 480 300</p>	<p>YY = CONFIGURATION 1P = SINGLE PHASE SP = SPLIT PHASE 3P = THREE PHASE DC = DIRECT CURRENT</p>	

Power Protection - Dinrail Test Class 1 and 2 Protectors

Shunt protection for power circuits

<p>(E)DTX YYY ZZ (R)</p> 	<p>(E)DTX = PRODUCT FAMILY DT1 = Dinrail IEC Test Class 1 DT2 = Dinrail IEC Test Class 2 EDT2 = Enhanced Dinrail IEC Test Class 2</p>	<p>YYY = VOLTAGE 75 = 75 V 150 = 150 V 300 = 300 V 350 = 350 V 480 = 480 V 550 = 550 V (EDT2 only) 750 = 750 V 880 = 880 V (EDT2 only)</p>	<p>ZZ = MODE 10 = 1 + 0 20 = 2 + 0 30 = 3 + 0 40 = 4 + 0 11 = 1 + 1 31 = 3 + 1</p>	<p>R = REMOTE CONTACTS</p>
---	---	---	---	-----------------------------------

Surge Protection Product Selection

Power Protection – Transient Surge Filters

Series protection for power circuits (6 A to 20 A)

<p>TSF XXA YYYY</p> 	<p>TSF = PRODUCT FAMILY</p>	<p>XX = LINE CURRENT 6 = 6 A 20 = 20 A</p>	<p>YYY = VOLTAGE 24 = 24 V (6 A only) 120 = 120 V 240 = 240 V</p>
--	------------------------------------	---	---

Power Protection – Surge Reduction Filters

Series protection for power circuits (63 A to 800 A)

<p>SRF XXXA N</p> 	<p>SRF = PRODUCT FAMILY</p>	<p>XXX = LINE CURRENT 63 = 63 A 125 = 125 A 250 = 250 A 500 = 500 A 800 = 800 A</p>	<p>N = N SERIES</p>
--	------------------------------------	---	----------------------------

Signal Protection – Universal Transient Barriers

General purpose signal protection

<p>UTB XXX SP</p> 	<p>UTB = PRODUCT FAMILY</p>	<p>XXX = VOLTAGE 5 = 5 V 15 = 15 V 30 = 30 V 60 = 60V 110 = 110V</p>	<p>SP = SINGLE PAIR DP = DUAL PAIR</p>
--	------------------------------------	--	---

Telephone line protection

<p>UTBSA</p> 	<p>UTB = PRODUCT FAMILY</p>	<p>SA = TELEPHONE TA = TELEPHONE, UL LISTED</p>
---	------------------------------------	--

Signal Protection – Coaxial Surge Protection

General purpose coaxial cable protection

<p>CSP1 XXX YYY</p> 	<p>CSP1 = PRODUCT FAMILY</p>	<p>XXX = CONNECTOR NB = N type, F-F bulkhead NMF = N type, male-female BNC = BNC type, male-female SMA = SMA type, male-female F = F Type male-female</p>	<p>YYY = MODE 90 = 90 V 600 = 600 V</p>
--	-------------------------------------	---	--

Surge Protection Product Selection

Signal Protection – High Speed & Subscriber Line Protection

High Speed twisted pair Krone block protection

<p>HSP 10 K XXX</p> 	<p>HSP = PRODUCT FAMILY</p>	<p>10 = 10 PAIR</p>	<p>K = KRONE BLOCK</p>	<p>XXX = VOLTAGE 12 = 12 V 36 = 36 V 72 = 72 V 230 = 230 V</p>
--	------------------------------------	----------------------------	-------------------------------	---

General twisted pair Krone block protection

<p>SLP 1 RJ11</p> 	<p>SLP = PRODUCT FAMILY</p>	<p>1 = 1 PAIR</p>	<p>RJ11A = RJ11 CONNECTOR RJ11 = RJ11 CONNECTOR, UL LISTED</p>
--	------------------------------------	--------------------------	---

<p>SLP 10 K1F</p> 	<p>SLP = product family</p>	<p>10 = 10 pair</p>	<p>K = Krone block</p>
---	------------------------------------	----------------------------	-------------------------------

Signal Protection – Closed Circuit & Cable TV

Coaxial Cable CCTV

<p>CCTV 12</p> 	<p>CCTV = PRODUCT FAMILY</p>	<p>12 = voltage</p>
---	-------------------------------------	----------------------------

Closed Circuit & CATVHF Section

<p>CATVHF</p> 	<p>CATVHF1 = PRODUCT FAMILY</p>
--	--

Signal Protection – Local Area Network

General Purpose RJ45 protection

<p>LAN RJ45 C6P</p> 	<p>LAN = PRODUCT FAMILY</p>	<p>RJ45 = connector</p>	<p>C6P = Category 6 Protection</p>
--	------------------------------------	--------------------------------	---

SES40P

SERVICE ENTRANCE SUPPRESSION



SES40P shown with optional Flush Plate (SES40PPF)

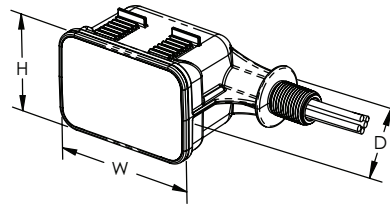

Features

- Compact NEMA®-4X enclosure design can be flush mounted or installed in a small space
- LED status indication flag for status monitoring
- 40 kA 8/20 μ s maximum surge rating per mode protection suitable for service entrance and distribution panels
- CE, UL® 1449 Edition 4 Listed, CSA-22.2
- Optional bracket for mounting within panel backplane SES40PBRK

The nVent ERICO SES40P Series of Surge Protective Devices (SPD) provide economical protection against damaging transients and surge events. These Type 1 devices are UL® Listed to UL 1449 Edition 4 and cUL® Listed to CAN/CSA C233.1. This allows installations on the line or load side (Type 1 or Type 2) of the service panel in accordance with the NEC® 2014 or CAN/CSA C233.1 without the requirement for additional circuit breakers or fuses. Primary applications are service entrance, branch,

commercial, industrial, and residential. Other applications include OEM panels, solar combiner boxes, UL 96A lightning protection installations and light pole applications. The housing is constructed of UV-stabilized thermoplastic and meets the UL 50 Type 4x rating, making it ideal for both indoor and outdoor applications. All of the models have a 20kA nominal discharge current rating, the highest level recognized under the UL 1449 Edition 4 standard.

Part Number	SES40P120/240SP	SES40P1201P	SES40P2083P	SES40P2401P	SES40P4801P	SES40P4803P	SES40P300DC
Nominal System Voltage (U_n)	120/240 VAC	120 VAC	120/208 VAC	240 VAC	277/480 VAC	277/480 VAC	300 VDC
Distribution System	1Ph 2W+G		3Ph 4W+G 3Ph Δ 3W+G	1Ph 2W+G		3Ph 4W+G 3Ph Δ 3W+G	DC 2W+G
Max Continuous Operating Voltage (U_c)	150/300 VAC	150 VAC	150/300 VAC	300 VAC	340/590 VAC	340/590 VAC	360 VDC
Frequency	0 – 100 Hz						–
Short Circuit Current Rating (SCCR)	200 kA						100 kA
Nominal Discharge Current (I_n), Per Mode	20 kA 8/20 μ s						
Max Discharge Current (I_{max}), Per Mode	40 kA 8/20 μ s						
Voltage Protection Rating (VPR),	L-L 1,800 V L-N 900 V	L-N 1,800 V L-PE 900 V N-PE 900 V	L-L 1,800 V L-N 900 V L-PE 1,800 V N-PE 900 V	L-N 2,500 V L-PE 1,500 V N-PE 1,200 V	L-L 2500 V L-N 1500 V L-PE 2500 V N-PE 1500 V	L-L 2,500 V L-N 1,500 V L-PE 2,500 V N-PE 1,500 V	DC+ - DC- 2,500 V PE - DC- 1,500 V PE - DC+ 1,500 V
Status Indication	Blue LED						
Technology	MOV with thermal disconnect						
Lead Length	36"						30"
Lead Size	#12						
Temperature	-40 to 176 °F						
Enclosure Material	UL® 94V-0 Thermoplastic, UL 50 Type 4X						
Enclosure Rating	UL 50E Type 4X, NEMA 4X, IP65						NEMA®-4X
Mounting	1/2" straight nipple						3/4" straight nipple
Unit Weight	0.55 lb		0.85 lb	0.55 lb		0.85 lb	0.55 lb
Certification Details	UL® 1449 Edition 4 Type 1/2, 20 kA Mode						UL® 1449 Edition 4 for DC General Use, Solar PV
Complies With	ANSI®/IEEE® C62.41.2-2002 Cat A, Cat B, Cat C						
Dimensions H x D x W	2 3/4" x 3" x 4 3/4"						

SES40

SERVICE ENTRANCE SUPPRESSOR, 40 KA, METAL

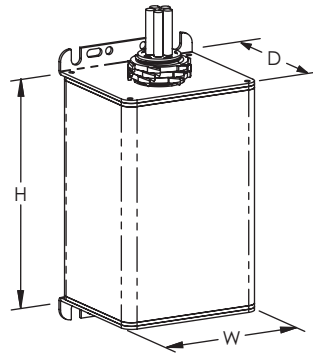
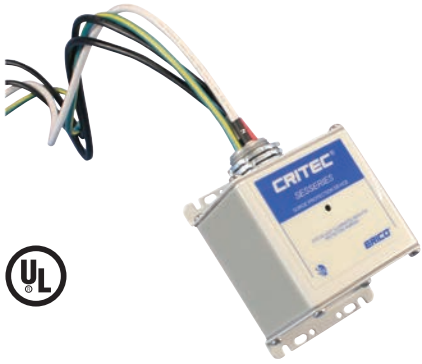

Features

- Compact NEMA®-4 enclosure design can be flush mounted or installed in a small space
- LED status indication flag for status monitoring
- 120/240 VAC operating voltage suits the most common power distribution system for residential or small commercial buildings
- 40 kA 8/20 μ s maximum surge rating (per mode) provides protection suitable for service entrance and distribution panels

Part Number	SES40120/240
Nominal System Voltage (Un)	120/240 V
Distribution System	1Ph 3W+G
Max Continuous Operating Voltage (Uc)	170/276 VAC
Frequency	50 – 60 Hz
Short Circuit Current Rating (SCCR)	200 kA
Nominal Discharge Current (In)	20 kA 8/20 μ s
Max Discharge Current (Imax)	40 kA 8/20 μ s per mode
Voltage Protection Rating (VPR)	800 V @ 3 kA; 1,200 V @ 20 kA
Protection Modes	L-L; L-N; L-PE
Status Indication	LED
Technology	MOV with thermal disconnect
Lead Length	30"
Lead Size	#10
Ground Lead Length	36"
Temperature	-40 to 176 °F
Enclosure Material	Metal
Enclosure Rating	IP 65 NEMA®-4
Mounting	3/4" straight nipple
Depth (D)	2.87"
Height (H)	3.27"
Width (W)	3.27"
Unit Weight	1.54 lb
Certification Details	UL® 1449 Edition 4 Type 1/2, 20 kA Mode
Complies With	ANSI®/IEEE® C62.41.2-2002 Cat A, Cat B, Cat C ANSI®/IEEE® C62.41.2-2002 Scenario II, Exposure 2, 20 kA 8/20 μ s, 2 kA 10/350 μ s IEC® 61643-1 Class II
Certifications	UL
Standard Packaging Quantity	1 pc

SES200

TRANSIENT DISCRIMINATING SERVICE ENTRANCE SUPPRESSOR

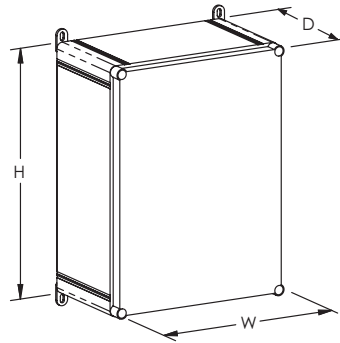

Features

- 200kA 8/20 μ s primary protection – rated for service entrance applications
- NEMA®-4X enclosure – for harsh environments
- Internal high interrupt capacity fusing – for added safety
- Modular design – allows easy replacement of surge modules
- Built in disconnect and fusing eliminates need for external fusing
- Transient Discriminating (TD) Technology – provides increased service life
- Optional Filter and Surge Counter – for enhanced protection
- UL® 1449 4th Edition

The SES200 series of Transient Voltage Surge Suppressors deliver specification grade performance and features at an affordable price. The versatile and compact design provides high quality protection for a wide variety of commercial and industrial applications where sensitive electronic equipment is to be protected.

Internal electronics continuously monitor SPD protection, and the status is displayed on 5 segment LED bar graphs. Alarm contacts for remote monitoring are a standard feature.

The SES200 provides up to 200kA 8/20 μ s per mode of surge material, making it ideal for the protection of service entrance panels and helping to ensure a long operational life under severe lightning conditions.

The replaceable surge modules provide protection to L-N and N-G modes, delivering effective protection from both common mode and differential transients in single phase and three phase WYE systems. Models for grounded delta power systems provide L-L protection.

Transient Discriminating (TD) Technology, which meets the safety standards of UL 1449 Edition 4, provides a superior life by eliminating the common temporary over-voltage failure mode of most SPDs.

The SES is designed to mount adjacent to the service entrance panel with the connection being made via a small length of conduit.



SES200 metal enclosure option



SES200 without filter or surge counter options

Note: Ensure that installation of this model of the SES200 is not exposed to direct sunlight as solar radiation may cause internal temperatures to exceed the maximum specified and damage will result to the surge protective modules. A sun shield should be fitted if this unit is to be installed outdoors and exposed to sunlight.

SES200

TRANSIENT DISCRIMINATING SERVICE ENTRANCE SUPPRESSOR

Model	SES200 120/208	SES200 120/240	SES200 240D	SES200 277/480	SES200 120/208CM	SES200 120/240CM	SES200 240DCM	SES200 277/480CM
Nominal Voltage, U _n	120/208 V	120/240 V	220/240 V	277/480 V	120/208 V	120/240 V	220/240 V	277/480 V
Distribution System	3Ph Y 4W+G	1Ph 3W+G	3Ph Δ 3W+G	3Ph Y 4W+G		1Ph 3W+G	3Ph Δ 3W+G	3Ph Y 4W+G
System Compatibility(1)	TN-C, TN-S, TN-C-S							
Max Cont. Operating Voltage, U _c	170/295 VAC	170/340 VAC	400 VAC	400/692 VAC	170/295 VAC	170/340 VAC	400 VAC	400/692 VAC
Stand-off Voltage	240/415 V	240/480 V	275 V	480/831 V	240/415 V	240/480 V	275 V	480/831 V
Frequency	50/60 Hz							
Operating Current @ U _n	25 mA							
Aggregate Surge Rating	200kA (8/20μs per line)							
Impulse Current, I _{imp}	20 kA 10/350 μs							
Max Discharge Current, I _{max}	100 kA 8/20 μs per line							
Nominal Discharge Current, I _n (UL)	20 kA 8/20 μs							
Protection Modes	All modes protected		L-L	All modes protected			L-L	All modes protected
Technology	MOV/Silicon with over-current fusing; TD Technology							
Short Circuit Current Rating	200 kAIC							
Voltage Protection Rating (VPR)	L-N 600 V @ 3 kA 800 V @ 20 kA	L-L 900 V @ 3 kA 1.0 kV @ 20 kA	L-L 900 V @ 3 kA 1.0 kV @ 20 kA	L-N 900 V @ 3 kA 1.0 kV @ 20 kA	L-N 600 V @ 3 kA 800 V @ 20 kA	L-L 900 V @ 3 kA 1.0 kV @ 20 kA	L-L 900 V @ 3 kA 1.0 kV @ 20 kA	L-N 900 V @ 3 kA 1.0 kV @ 20 kA
Filtering					-40 dB @ 100 kHz			
Status(2)	5 segment LED bar graph per phase				5 segment LED bar graph per phase, surge counter			
Dimensions H x D x W: mm (in)	406 x 190 x 305 (16 x 7.5 x 12)				406 x 190 x 355 (16 x 7.5 x 14)			
Weight: kg (lbs)	8 (17.64)				13 (28.66)			
Enclosure	IP66 (NEMA®-4X), Polycarbonate				IP66 (NEMA-4), Metal (Steel)			
Connection	3mm ² to 35mm ² (#12AWG to #2AWG)							
Mounting	Wall mount							
Back-up Overcurrent Protection	Fused disconnect included in enclosure							
Temperature	-10°C to 60°C (14°F to 140°F)							
Approvals	NOM, UL® 1449 Edition 4 Listed Type 1/2							
Surge Rated to Meet	ANSI®/IEEE® C62.41.2-2002 Cat A, Cat B, Cat C ANSI®/IEEE® C62.41.2-2002 Scenario II, Exposure 3, 100 kA 8/20 μs, 10 kA 10/350 μs UL 1449 Edition 4 In 20 kA mode							

(2) Normally open contact, 250V~10A, ≤1.5 mm² (#16AWG) connecting wire.

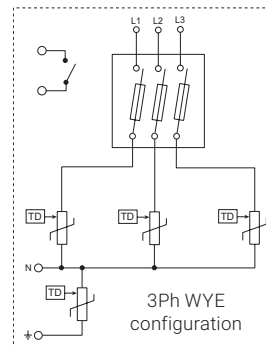
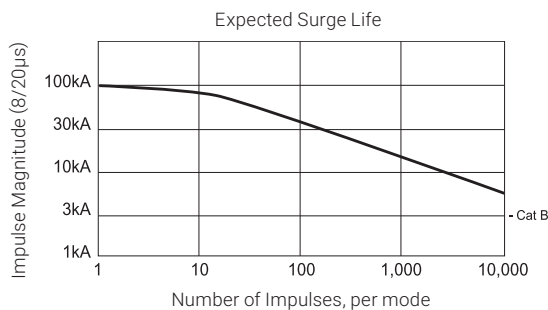

TDXM Modular Series

TDX400S TRANSIENT DISCRIMINATING PANEL PROTECTION

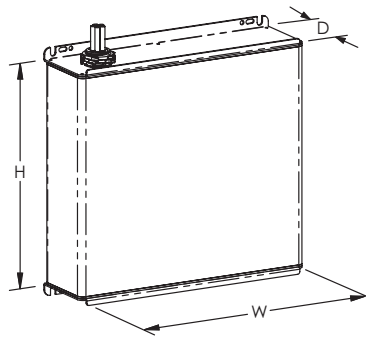

Features

- Transient Discriminating (TD) Technology provides increased service life
- Modular design allows individual modes to be field replaceable, built-in disconnect and fusing eliminates need for external fusing
- Built-in features include TD Technology, thermal protection, short circuit current cartridge fusing and a surge counter
- Status indication flag per mode, voltage presence LED's, audible alarm, surge counter, and voltage-free contacts providing remote status monitoring
- Available in various operating voltages to suit most common power distribution systems
- 400kA 8/20 μ s maximum surge rating provides protection suitable for service entrance, main-distribution panels and highly exposed applications
- CE, UL[®] 1449 Edition 4 Listed

The TDX400 Series of Transient Voltage Surge Suppressors is designed for critical protection applications. The 400kA 8/20 μ s of surge protection exceeds the IEEE[®] C62.41.2 Scenario II single shot surge rating requirements for exposed service entrance locations – Exposure 3.

The NEMA[®]-12/3R weather-tight housing.

The preconfigured connecting leads simplify installation.

The unique narrow construction allows the SPD to fit between adjacent panel boards and connect via a 90-degree elbow.

Listed as a Type 1 SPD to UL 1449 Edition 4, the TDX400 Series can be installed within a Type 1 or 2 location in accordance with the NEC[®] 2017, Article 285.

Part Number	TDX400S120/208	TDX400S120/240	TDX400S277/480
Nominal System Voltage (U _n)	120/208 V	120/240 V	277/480 V
Distribution System	3Ph 4W+G	1Ph 3W+G	3Ph 4W+G
Max Continuous Operating Voltage (U _c)	170/276 VAC		320/550 VAC
Stand-off Voltage	240/415 VAC	240/480 VAC	480/831 VAC
Frequency	50 – 60 Hz		
Short Circuit Current Rating (SCCR)	200 kA		
Nominal Discharge Current (I _n), IEC	40 kA 8/20 μ s		
Nominal Discharge Current (I _n), UL	20 kA 8/20 μ s		
Max Discharge Current (I _{max}), Per Phase	400 kA 8/20 μ s		
Impulse Current (I _{imp}), Per Mode	25 kA 10/350 μ s		
Voltage Protection Rating (VPR), L-N	800 V @ 3 kA		1,200 V @ 3 kA
Protection Modes	L-N L-PE N-PE		
Status Indication	LED, Mechanical flag Audible alarm		
Surge Counter	Yes		
Technology	TD technology with thermal disconnect Over-current replaceable cartridge fusing		
Remote Contacts	Yes		
Lead Length	30"		
Lead Size	#10		
Ground Lead Length	36"		
Temperature	-40 to 176 °F		
Enclosure Material	Metal		
Enclosure Rating	IP 20 NEMA [®] -12/3R		
Mounting	3/4" straight nipple		
Dimensions H x D x W	10.40" x 3.25" x 10.32"		
Unit Weight	14 lb		
Certification Details	UL [®] 1449 Edition 4 Type 1/2, 20 kA Mode		
Complies With	ANSI/IEEE [®] C62.41.2-2002 Scenario II, Exposure 3, 100 kA 8/20 μ s, 10 kA 10/350 μ s IEC [®] 61643-1 Class I, Class II		
Replacement Module	TDS150M150		TDS150M277

ANSI is a registered trademark of the American National Standards Institute. IEC is a registered trademark of the International Electrotechnical Commission. IEEE is a registered trademark of the Institute of Electrical and Electronics Engineers, Incorporated. NEMA is a registered trademark of the National Electrical Manufacturers Association. UL is a registered certification mark of UL LLC.

TDXM Modular Series

TDX300S TRANSIENT DISCRIMINATING PANEL PROTECTION

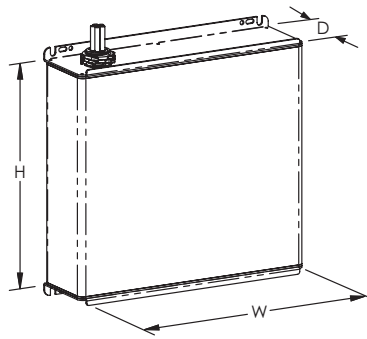

Features

- Transient Discriminating (TD) Technology provides increased service life
- Modular design allows individual modes to be field replaceable, built-in disconnect and fusing eliminates need for external fusing
- Built-in features include TD Technology, thermal protection, short circuit current cartridge fusing and surge counter
- Status indication flag per mode, voltage presence LED's, audible alarm surge counter and voltage-free contacts providing remote status monitoring
- Available in various operating voltages to suit most common power distribution systems
- 300kA 8/20 μ s maximum surge rating provides protection suitable for service entrance, main-distribution panels and highly exposed applications
- CE, UL[®] 1449 Edition 4 Listed

The TDX300 Series of Transient Voltage Surge Suppressors is designed for critical protection applications. The 300kA 8/20 μ s of surge protection exceeds the IEEE[®] C62.41.2 Scenario II single shot surge rating requirements for exposed service entrance locations – Exposure 3.

The NEMA[®]-12/3R weather-tight housing.

The preconfigured connecting leads simplify installation. The unique narrow construction allows the SPD to fit between adjacent panel boards and connect via a 90-degree elbow.

Listed as a Type 1 SPD to UL 1449 Edition 4, the TDX300 Series can be installed within a Type 1 or 2 location in accordance with the NEC[®] 2017.

Part Number	TDX300S120/208	TDX300S120/240	TDX300S277/480
Nominal System Voltage (U_n)	120/208 V	120/240 V	277/480 V
Distribution System	3Ph 4W+G	1Ph 3W+G	3Ph 4W+G
Max Continuous Operating Voltage (U_c)	170/276 VAC		320/550 VAC
Stand-off Voltage	240/415 V	240/480 V	480/831 V
Frequency	50 – 60 Hz		
Short Circuit Current Rating (SCCR)	200 kA		
Nominal Discharge Current (I_n), IEC	40 kA 8/20 μ s		
Nominal Discharge Current (I_n), UL	20 kA 8/20 μ s		
Max Discharge Current (I_{max}), Per Phase	300 kA 8/20 μ s		
Impulse Current (I_{imp}), Per Mode	23 kA 10/350 μ s		
Voltage Protection Rating (VPR), L-N	800 V @ 3 kA		1,200 V @ 3 kA
Protection Modes	L-N L-PE N-PE		
Status Indication	LED, Mechanical flag Audible alarm		
Surge Counter	Yes		
Technology	TD technology with thermal disconnect Over-current replaceable cartridge fusing		
Remote Contacts	Yes		
Lead Length	30"		
Lead Size	#10		
Ground Lead Length	36"		
Temperature	-40 to 176 °F		
Enclosure Material	Metal		
Enclosure Rating	IP 20 NEMA [®] -12/3R		
Mounting	3/4" straight nipple		
Dimensions H x D x W	10.40" x 3.25" x 10.32"		
Unit Weight	13 lb		
Certification Details	UL [®] 1449 Edition 4 Type 1/2, 20 kA Mode		
Complies With	ANSI [®] /IEEE [®] C62.41.2-2002 Scenario II, Exposure 3, 100 kA 8/20 μ s, 10 kA 10/350 μ s IEC [®] 61643-1 Class I, Class II		
Replacement Module	TDS150M150		TDS150M277

ANSI is a registered trademark of the American National Standards Institute. IEC is a registered trademark of the International Electrotechnical Commission. IEEE is a registered trademark of the Institute of Electrical and Electronics Engineers, Incorporated. NEMA is a registered trademark of the National Electrical Manufacturers Association. UL is a registered certification mark of UL LLC.

TDXM Modular Series

TDX200 TRANSIENT DISCRIMINATING PANEL PROTECTION

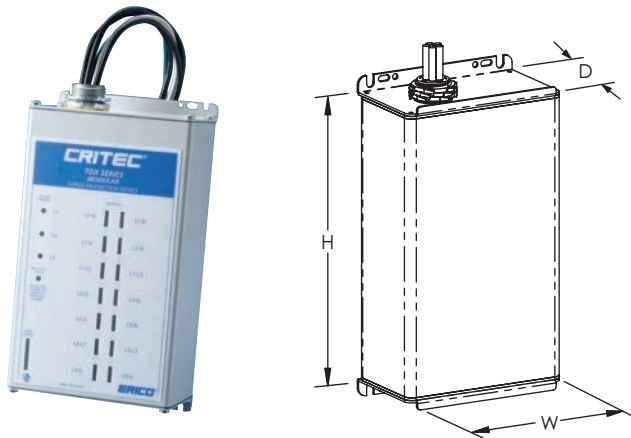

Features

- Transient Discriminating (TD) Technology provides increased service life
- Modular design allows individual modes to be field replaceable, built-in disconnect and fusing eliminates need for external fusing
- Built-in features include TD Technology, thermal protection and short circuit current cartridge fusing
- Compact NEMA®-4 enclosure design can be flush mounted or installed in a small space
- Status indication flag per mode, voltage presence LED's, audible alarm and voltage-free contacts providing remote status monitoring
- 200kA 8/20µs maximum surge rating provides protection suitable for service entrance, main-distribution panels and highly exposed applications
- Available in various operating voltages to suit most common power distribution systems
- CE, UL® 1449 Edition 4 Listed, CSA-22.2 (347/600v model)
- 'S' Versions of the TDX200 include a surge counter and a surge filter

The TDX200 Series of Transient Voltage Surge Suppressors is designed for critical protection applications. The 200kA 8/20µs of surge protection exceeds the IEEE® C62.41.2 Scenario II single shot surge rating requirements for exposed service entrance locations – Exposure 3.

The NEMA-4 weather-tight housing allows the TDX to be installed on indoor or outdoor service panels. The preconfigured connecting leads simplify installation. The unique narrow

construction allows the SPD to fit between adjacent panel boards and connect via a 90-degree elbow. A flush mounting kit (p/n TDXM200FP) is also available for installing the SPD in drywall applications. A side mount kit (p/n TDXSM) is also available.

Listed as a Type 1 SPD to UL 1449 Edition 4, the TDX200 Series can be installed within a Type 1 or 2 location in accordance with the NEC® 2017

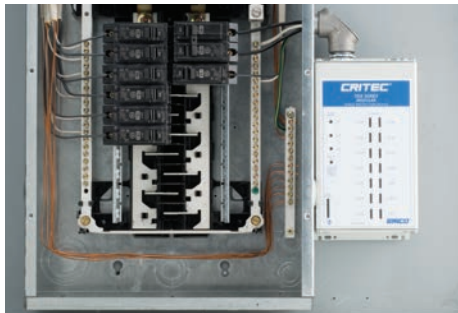

Typical installation



TDX200M Enclosure



TDX Replaceable Modules



TDX Replaceable Module backplane fully removed

TDXM Modular Series

TDX200 TRANSIENT DISCRIMINATING PANEL PROTECTION

Part Number	TDX200M 120/208	TDX200M 120/240	TDX200M 277/480	TDX200M 347/600	TDX200M 120/240D	TDX200M 240D	TDX200M 480D
Nominal System Voltage (Un)	120/208 V	120/240 V	277/480 V	347/600 V	120/240 V	240 VAC	480 V
Distribution System	3Ph 4W+G	1Ph 3W+G	3Ph 4W+G		3PhΔ 4W+G	3PhΔ 3W+G	
Max Continuous Operating Voltage (Uc)	170/276 VAC		320/550 VAC	550/1100 VAC	170/276 VAC	276 VAC	550 VAC
Stand-off Voltage	240/415 VAC	240/480 VAC	480/831 VAC	790/1370 VAC	240/415 VAC	415 VAC	790 VAC
Frequency	50 – 60 Hz						
Short Circuit Current Rating (SCCR)	200 kA						
Nominal Discharge Current (In), IEC	40 kA 8/20 μs						
Nominal Discharge Current (In), UL	20 kA 8/20 μs						
Max Discharge Current (Imax), Per Phase	200 kA 8/20 μs						
Impulse Current (Iimp), Per Mode	25 kA 10/350 μs						
Voltage Protection Rating (VPR)	600 V @ 3 kA L-N 1,200 V @ 20 kA L-N		1,000 V @ 3 kA L-N 1,800 V @ 20 kA L-N	1,800 V @ 3 kA L-N 2,600 V @ 20 kA L-N	600 V @ 3 kA L-N 1,200 V @ 20 kA L-N	1,000 V @ 3 kA L-L 1,800 V @ 20 kA L-L	1,800 V @ 3 kA L-L 2,600 V @ 20 kA L-L
Filtering (S Option)	-40dB @ 100 kHz						
Protection Modes	L-N L-PE N-PE						
Status Indication	LED Mechanical flag Audible alarm						
Surge Counter	Yes, S version						
Technology	TD technology with thermal disconnect Over-current replaceable cartridge fusing						
Remote Contacts	Yes						
Lead Length	30"						
Lead Size	#10						
Ground Lead Length	36"						
Temperature	-40 to 176 °F						
Enclosure Material	Metal						
Enclosure Rating	IP 65 NEMA®-4						
Mounting	3/4" straight nipple						
Dimensions H x D x W	9.45" x 3.07" x 5.12"						
Unit Weight	4.4 lb						
Certification Details	UL® 1449 Edition 4 Type 1/2, 20 kA Mode				UL® 1449 Edition 4 Type 1/2, 20 kA Mode		
Complies With	ANSI®/IEEE® C62.41.2-2002 Cat A, Cat B, Cat C ANSI®/IEEE® C62.41.2-2002 Scenario II, Exposure 3, 100 kA 8/20 μs, 10 kA 10/350 μs IEC® 61643-1 Class I, Class II						
Replacement Module	TDS150M150		TDS150M277	TDS150M560	TDS150M150 TDS150M240	TDS150M240	TDS150M560
Certifications	CE; C-Tick UL			CE; C-Tick; cULus	CE; C-Tick		
Accessories	Flush Plate (TDXM200FP), Side Mount Kit (TDXSM), Fuse Replacement (TDXFUSE)						

Delta and "S" models are Type 2 devices.

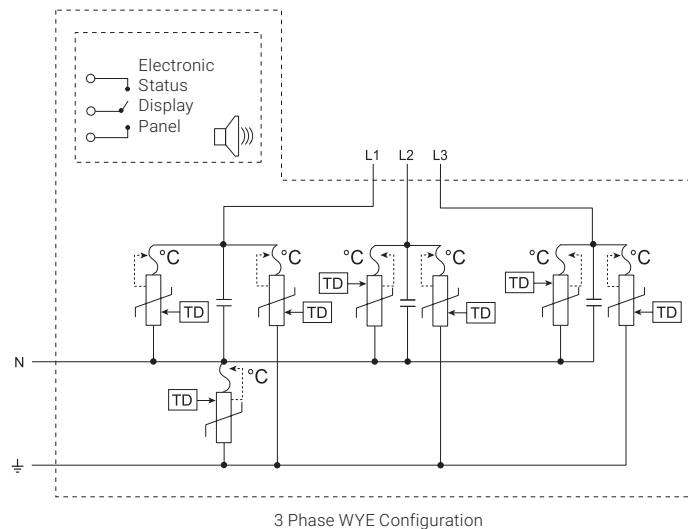

ANSI is a registered trademark of the American National Standards Institute. IEC is a registered trademark of the International Electrotechnical Commission. IEEE is a registered trademark of the Institute of Electrical and Electronics Engineers, Incorporated. NEMA is a registered trademark of the National Electrical Manufacturers Association. UL is a registered certification mark of UL LLC.

TDXM Modular Series

TDX100 TRANSIENT DISCRIMINATING PANEL PROTECTION

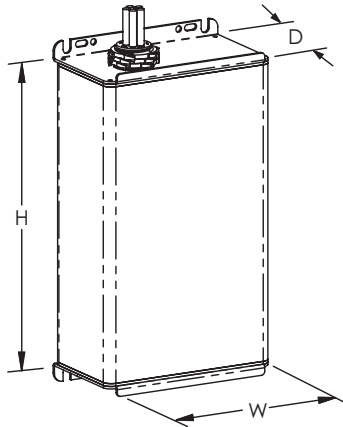

Features

- Transient Discriminating (TD) Technology provides increased service life
- Modular design allows individual modes to be field replaceable, built-in disconnect and fusing eliminates need for external fusing
- Built-in features include TD Technology, thermal protection and short circuit current cartridge fusing
- Compact NEMA®-4 enclosure design can be flush mounted or installed in a small space
- Status indication flag per mode, voltage presence LEDs, audible alarm and voltage-free contacts providing remote status monitoring
- 100kA 8/20µs maximum surge rating provides protection suitable for smaller main-distribution panels and an extended operational life
- Available in various operating voltages to suit most common power distribution systems
- CE, UL® 1449 Edition 4 Listed, CSA-22.2 (347/600v model)
- S' Versions of the TDX100 include a surge counter and a surge filter

The TDX100 Series of Transient Voltage Surge Suppressors is designed for critical protection applications. The 100kA 8/20µs of surge protection meets the IEEE® C62.41.2 Scenario II single shot surge rating requirements for exposed service entrance locations – Exposure 3.

The NEMA-4 weather tight housing allows the TDX to be installed on indoor or outdoor service panels. The preconfigured connecting leads simplify installation. The unique narrow

construction allows the SPD to fit between adjacent panel boards and connect via a 90-degree elbow. A flush mounting kit (p/n TDXM100FP) is also available for installing the SPD in drywall applications. A side mount kit (p/n TDXSM) is also available.

Listed as a Type 1 SPD to UL 1449 Edition 4, the TDX100 Series can be installed within a Type 1 or 2 location in accordance with the NEC® 2017.



Typical Installation



Output contacts



TDX Replaceable Cartridge
overcurrent fuse protection



TDX Replaceable Modules

TDXM Modular Series

TDX100 TRANSIENT DISCRIMINATING PANEL PROTECTION

Part Number	TDX100M120/208	TDX100M120/240	TDX100M277/480	TDX100M347/600	TDX100M120/240D	TDX100M240D	TDX100M480D
Nominal System Voltage (U _n)	120/208 V	120/240 V	277/480 V	347/600 V	120/240 V	240 VAC	480 V
Distribution System	3Ph 4W+G	1Ph 3W+G	3Ph 4W+G	3Ph 4W+G	3PhΔ 4W+G	3PhΔ 3W+G	3Ph 3W+G
Max Continuous Operating Voltage (U _c)	170/276 VAC		320/550 VAC	550/1100 VAC	170/276 VAC	276 VAC	550 VAC
Stand-off Voltage	240/415 VAC	240/480 VAC	480/831 VAC	790/1370 VAC	240/415 VAC	415 VAC	790 VAC
Frequency	50 – 60 Hz						
Short Circuit Current Rating (SCCR)	200 kA						
Nominal Discharge Current (I _n), IEC	40 kA 8/20 μs						
Nominal Discharge Current (I _n), UL	20 kA 8/20 μs						
Max Discharge Current (I _{max}), Per Phase	100 kA 8/20 μs						
Impulse Current (I _{imp}), Per Mode	12.5 kA 10/350 μs						
Voltage Protection Rating (VPR), L-L	-					1,000 V @ 3 kA 1,800 V @ 20 kA	1,800 V @ 3 kA 2,600 V @ 20 kA
Voltage Protection Rating (VPR), L-N	600 V @ 3 kA 1,200 V @ 20 kA		1,200 V @ 3 kA 1,800 V @ 20 kA	1,800 V @ 3 kA 2,600 V @ 20 kA	600 V @ 3 kA 1,200 V @ 20 kA	-	
Filtering (S Option)	-40dB @ 100 kHz						
Protection Modes	L-N L-PE N-PE						
Status Indication	LED, Mechanical flag, Audible alarm						
Surge Counter	Yes, S version						
Technology	TD technology with thermal disconnect Over-current replaceable cartridge fusing EMI/RFI filter (S versions)						
Remote Contacts	Yes						
Lead Length	30"						
Lead Size	#10						
Ground Lead Length	36"						
Temperature	-40 to 176 °F						
Enclosure Material	Metal						
Enclosure Rating	IP 65 NEMA®-4						
Mounting	3/4" straight nipple						
Dimensions H x D x W	9.45" x 3.07" x 3.31"						
Unit Weight	3.1 lb						
Certification Details	UL® 1449 Edition 4 Type 2, 20 kA Mode						
Complies With	ANSI®/IEEE® C62.41.2-2002 Cat A, Cat B, Cat C ANSI®/IEEE® C62.41.2-2002 Scenario II, Exposure 3, 100 kA 8/20 μs, 10 kA 10/350 μs IEC® 61643-1 Class I, Class II						
Replacement Module	TDS150M150		TDS150M277	TDS150M560	TDS150M150 TDS150M240	TDS150M240	TDS150M560
Accessories	Flush Plate (TDXM100FP), Side Mount Kit (TDXSM), Fuse Replacement (TDXFUSE)						

Delta and "S" models are Type 2 devices.

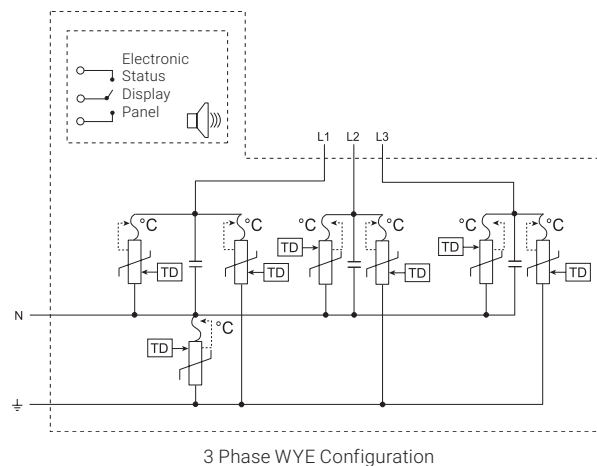

ANSI is a registered trademark of the American National Standards Institute. IEC is a registered trademark of the International Electrotechnical Commission. IEEE is a registered trademark of the Institute of Electrical and Electronics Engineers, Incorporated. NEMA is a registered trademark of the National Electrical Manufacturers Association. UL is a registered certification mark of UL LLC.

TDXC Compact Series

TDX200C TRANSIENT DISCRIMINATING PANEL PROTECTION

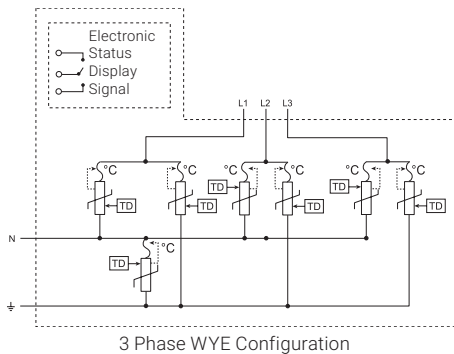
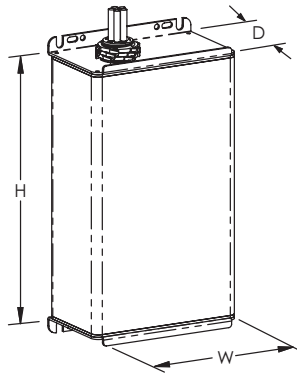

Features

- Transient Discriminating (TD) Technology provides increased service life
- Built-in features include TD Technology, thermal protection and short circuit current fusing
- Compact NEMA®-4 enclosure design can be flush mounted or installed in a small space
- LED status indication and voltage-free contacts provide remote status monitoring
- 200kA 8/20µs maximum surge rating provides protection suitable for smaller main-distribution panels and an extended operational life
- Available in various operating voltages to suit most common power distribution systems
- CE, UL® 1449 Edition 4 Listed

The TDX200 Series of Transient Voltage Surge Suppressors is designed for critical protection applications. The 200kA 8/20µs of surge protection exceeds the IEEE® C62.41.2 Scenario II single shot surge rating requirements for exposed service entrance locations – Exposure 3.

The NEMA-4 weather-tight housing allows the TDX to be installed on indoor or outdoor service panels. The preconfigured connecting leads simplify installation.

The unique narrow construction allows the SPD to fit between adjacent panel boards and connect via a 90-degree elbow. A flush mounting kit (p/n TDX200CFPP) is also available for installing the SPD in drywall applications.

Listed as a Type 1 SPD to UL 1449 Edition 4, the TDX200 Series can be installed within a Type 1 or 2 location in accordance with the NEC® 2017.

Part Number	TDX200C120/208	TDX200C120/240	TDX200C277/480
Nominal System Voltage (U _n)	120/208 V	120/240 V	277/480 V
Distribution System	3Ph 4W+G	1Ph 3W+G	3Ph 4W+G
Max Continuous Operating Voltage (U _c)	170/276 VAC		320/550 VAC
Stand-off Voltage	240/415 V	240/480 V	480/831 V
Frequency	50 – 60 Hz		
Short Circuit Current Rating (SCCR)	200 kA		
Nominal Discharge Current (I _n), IEC	40 kA 8/20 µs		
Nominal Discharge Current (I _n), UL	20 kA 8/20 µs		
Max Discharge Current (I _{max}), Per Phase	200 kA 8/20 µs		
Impulse Current (I _{imp}), Per Mode	25 kA 10/350 µs		
Voltage Protection Rating (VPR), L-N	800 V @ 3 kA		1,200 V @ 3 kA
Protection Modes	L-N L-PE N-PE		
Remote Contacts	Yes		
Status Indication	LED		
Surge Counter	No		
Technology	Over-current fusing, TD technology with thermal disconnect		
Lead Size	#10		
Lead Length	30"		
Ground Lead Length	36"		
Temperature	-40 to 176 °F		
Part Number	TDX200C120/208	TDX200C120/240	TDX200C277/480
Enclosure Material	Metal		
Enclosure Rating	IP 65 NEMA®-4	NEMA®-4	
Mounting	3/4" straight nipple		
Dimensions H x D x W (in)	11" x 3.07" x 3.31"		
Unit Weight	4.5 lb		
Certification Details	UL® 1449 Edition 4 Type 1/2, 20 kA Mode		
Complies With	ANSI®/IEEE® C62.41.2-2002 Cat A, Cat B, Cat C ANSI®/IEEE® C62.41.2-2002 Scenario II, Exposure 1, 20 kA 8/20 µs, 2 kA 10/350 µs		

ANSI is a registered trademark of the American National Standards Institute. IEC is a registered trademark of the International Electrotechnical Commission. IEEE is a registered trademark of the Institute of Electrical and Electronics Engineers, Incorporated. NEMA is a registered trademark of the National Electrical Manufacturers Association. UL is a registered certification mark of UL LLC.

TDXC Compact Series

TDX100C TRANSIENT DISCRIMINATING PANEL PROTECTION

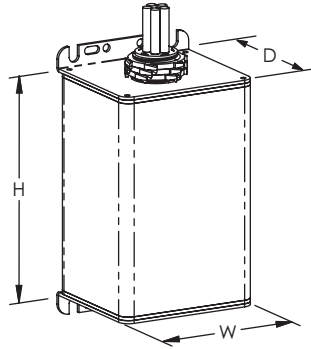

Features

- Transient Discriminating (TD) Technology provides increased service life
- Built-in features include TD Technology, thermal protection and short circuit current fusing
- Compact NEMA®-4 enclosure design can be flush mounted or installed in a small space
- LED status indication and voltage-free contacts provide remote status monitoring
- 100kA 8/20µs maximum surge rating provides protection suitable for smaller main-distribution panels and an extended operational life
- Available in various operating voltages to suit most common power distribution systems
- CE, UL® 1449 Edition 4 Listed

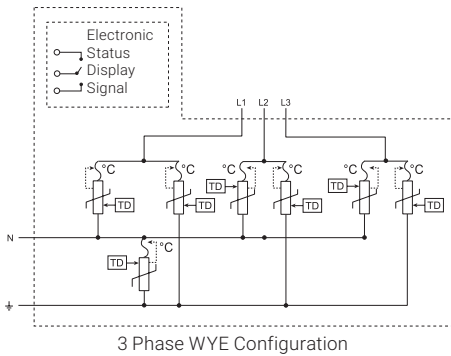

The TDX100 Series of Transient Voltage Surge Suppressors is designed for critical protection applications. The 100kA 8/20µs of surge protection meets the IEEE® C62.41.2 Scenario II single shot surge rating requirements for exposed service entrance locations – Exposure 3.

The NEMA-4 weather tight housing allows the TDX to be installed on indoor or outdoor service panels. The preconfigured

connecting leads simplify installation. The unique narrow construction allows the SPD to fit between adjacent panel boards and connect via a 90-degree elbow. A flush mounting kit (p/n TDXCFP) is also available for installing the SPD in drywall applications.

Listed as a Type 1 SPD to UL 1449 Edition 4, the TDX100 Series can be installed within a Type 1 or 2 location in accordance with the NEC® 2017.

Part Number	TDX100C120	TDX100C120/208	TDX100C120/240	TDX100C240	TDX100C277/480	TDX100C347/600
Nominal System Voltage (Un)	120 V	120/208 V	120/240 V	240 VAC	277/480 V	347/600 V
Distribution System	1Ph 2W+G	3Ph 4W+G	1Ph 3W+G	1Ph 2W+G	3Ph 4W+G	
Max Continuous Operating Voltage (Uc)	170 VAC	170/276 VAC		276 VAC	320/550 VAC	550/1100 VAC
Stand-off Voltage	240 VAC	240/415 VAC	240/480 VAC	480 VAC	480/831 VAC	600/1040 VAC
Frequency	50 – 60 Hz					
Short Circuit Current Rating (SCCR)	200 kA					
Nominal Discharge Current (In), IEC	40 kA 8/20 µs					
Nominal Discharge Current (In), UL	20 kA 8/20 µs					
Max Discharge Current (Imax), Per Phase	100 kA 8/20 µs					
Impulse Current (Iimp), Per Mode	12.5 kA 10/350 µs					
Voltage Protection Rating (VPR), L-N	600 V @ 3 kA 1,200 V @ 20 kA			1,000 V @ 3 kA 1,800 V @ 20 kA	1,200 V @ 3 kA 1,800 V @ 20 kA	1,800 V @ 3 kA 2,600 V @ 20 kA
Protection Modes	L-N, L-PE, N-PE					
Remote Contacts	Yes					
Status Indication	LED					
Surge Counter	No					
Technology	Over-current fusing, TD technology with thermal disconnect					
Lead Size	#10					
Lead Length	30"					
Ground Lead Length	36"					
Temperature	-40 to 176 °F					
Enclosure Material	Metal					
Enclosure Rating	IP 65 NEMA®-4					
Mounting	3/4" straight nipple					
Dimensions H x D x W:	6.02" x 3.07" x 3.31"					
Unit Weight	1.76 lb					
Certification Details	UL® 1449 Edition 4 Type 1/2, 20 kA Mode					
Complies With	ANSI®/IEEE® C62.41.2-2002 Cat A, Cat B, Cat C ANSI®/IEEE® C62.41.2-2002 Scenario II, Exposure 1, 20 kA 8/20 µs, 2 kA 10/350 µs					
Certifications	CE, C-Tick, UL			CE, C-Tick	CE, C-Tick, UL	CE, C-Tick

ANSI is a registered trademark of the American National Standards Institute. IEC is a registered trademark of the International Electrotechnical Commission. IEEE is a registered trademark of the Institute of Electrical and Electronics Engineers, Incorporated. NEMA is a registered trademark of the National Electrical Manufacturers Association. UL is a registered certification mark of UL LLC.

TDXC Compact Series

TDX50C TRANSIENT DISCRIMINATING PANEL PROTECTION

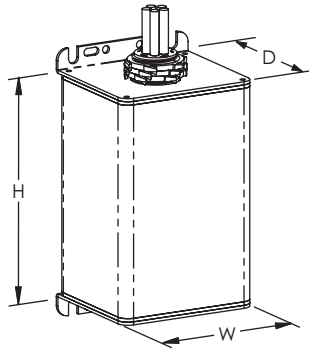

Features

- Transient Discriminating (TD) Technology provides increased service life
- Built-in features include TD Technology, thermal protection and short circuit current fusing
- Compact NEMA®-4 enclosure design can be flush mounted or installed in a small space
- LED status indication and voltage-free contacts provide remote status monitoring
- 50kA 8/20µs maximum surge rating provides protection suitable for sub-distribution panels and a long operational life
- Available in various operating voltages to suit most common power distribution systems
- CE, UL® 1449 Edition 4 Listed, CSA-22.2

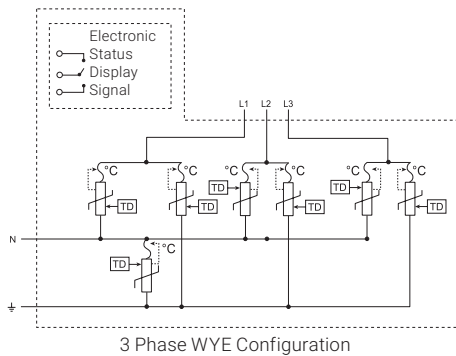

The TDX50 Series of Transient Voltage Surge Suppressors for equipment, panel and motor protection applications is specifically designed to provide long life, even under the most adverse over-voltage conditions.

The NEMA®-4 weather tight housing allows the TDX to be installed on indoor or outdoor service panels. The preconfigured connecting leads simplify installation.

The unique narrow construction allows the SPD to fit between adjacent panel boards. A flush mounting kit (p/n TDXCFP) is also available for installing the SPD in drywall applications.

Listed as a Type 1 SPD to UL 1449 Edition 4, the TDX50 Series can be installed within a Type 1 or 2 location in accordance with the NEC® 2017

Part Number	TDX50C120	TDX50C120/208	TDX50C120/240	TDX50C240	TDX50C277/480	TDX50C347/600	TDX50C120/240D
Nominal System Voltage (Un)	120 V	120/208 V	120/240 V	240 VAC	277/480 V	347/600 V	120/240 V
Distribution System	1Ph 2W+G	3Ph 4W+G	1Ph 3W+G	1Ph 2W+G	3Ph 4W+G	3Ph 4W+G	3PhΔ 4W+G
Max Continuous Operating Voltage (Uc)	170 VAC	170/276 VAC		276 VAC	320/550 VAC	550/1100 VAC	170/276 VAC
Stand-off Voltage	240 VAC	240/415 VAC	240/480 VAC	480 VAC	480/831 VAC	600/1040 VAC	240/415 VAC
Frequency	50 – 60 Hz						
Short Circuit Current Rating (SCCR)	200 kA						
Nominal Discharge Current (In), IEC	40 kA 8/20 µs						
Nominal Discharge Current (In), UL	10 kA 8/20 µs						
Max Discharge Current (Imax), Per Phase	50 kA 8/20 µs						
Voltage Protection Rating (VPR), L-N	600 V @ 3 kA 1,200 V @ 20 kA			1,000 V @ 3 kA 1,800 V @ 20 kA	1,200 V @ 3 kA 1,800 V @ 20 kA	2,000 V @ 3 kA 2,600 V @ 20 kA	600 V @ 3 kA 1,200 V @ 20 kA
Protection Modes	L-N L-PE N-PE						
Remote Contacts	Yes						
Status Indication	LED						
Surge Counter	No						
Technology	Over-current fusing, TD technology with thermal disconnect						
Lead Size	#10						
Lead Length	30"						
Ground Lead Length	36"						
Temperature	-40 to 176 °F						
Enclosure Material	Metal						
Enclosure Rating	IP 65 NEMA®-4						
Mounting	3/4" straight nipple						
Dimensions H x D x W	6.02 x 3.07 x 3.31						
Unit Weight	1.54 lb						
Certification Details	UL® 1449 Edition 4 Type 1/2, 10 kA Mode						
Complies With	ANSI®/IEEE® C62.41.2-2002 Cat A, Cat B, Cat C ANSI®/IEEE® C62.41.2-2002 Scenario II, Exposure 2, 50 kA 8/20 µs IEC® 61643-1 Class I, Class II						
Certifications	CE, C-Tick UL			CE, C-Tick	CE, C-Tick, UL	CE, C-Tick, cULus	CE, C-Tick

ANSI is a registered trademark of the American National Standards Institute. IEC is a registered trademark of the International Electrotechnical Commission. IEEE is a registered trademark of the Institute of Electrical and Electronics Engineers, Incorporated. NEMA is a registered trademark of the National Electrical Manufacturers Association. UL is a registered certification mark of UL LLC.

Rail Primary Power Surge Protector

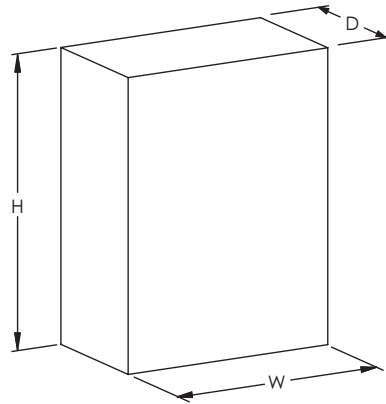

Features

- Modular design allows easy replacement of surge modules
- Terminals provided within panel
- Viewing window for safe inspection
- Internal high interrupt capacity fusing for added safety

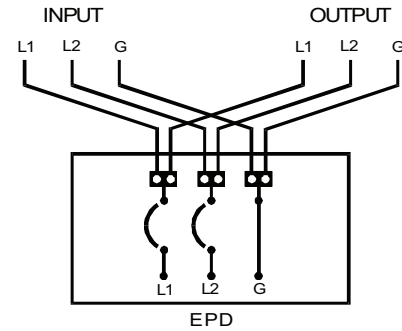

Part Number	EPD100HZ120240V	EPD100HZ120S	EPD100HZ120V
Nominal System Voltage (Un)	120/240 V	120 VAC	
Max Continuous Operating Voltage (Uc)	150/300 VAC	150 VAC	
Max Discharge Current (Imax), Per Mode	15 kA 8/20 μ s		
Nominal Discharge Current (In), Per Mode	40 kA 8/20 μ s		
Frequency	0 – 100 Hz		
Voltage Protection Level (Up)	1,400 V @ 15 kA	1,200 V @ 15 kA	
Short Circuit Current Rating (SCCR)	25 kA		
Connection, Stranded	#16 – #4	#14 – 2/0	#16 – #4
Protection Modes	Differential Common		
Status Indication	Mechanical flag		
Technology	MOV with thermal disconnect		
Humidity	0 – 90 % RH		
Temperature	-40 to 176 °F		
Enclosure Material	Metal		
Enclosure Rating	NEMA®-4		
Depth (D)	4.6"		
Height (H)	8"		
Width (W)	11 1/2"		
Unit Weight	12 lb		
Complies With	ANSI®/IEEE® C62.41.2-2002 Cat A, Cat B, Cat C; AREMA® requirements		

Rail Primary Power Surge Protector With Flying Lead

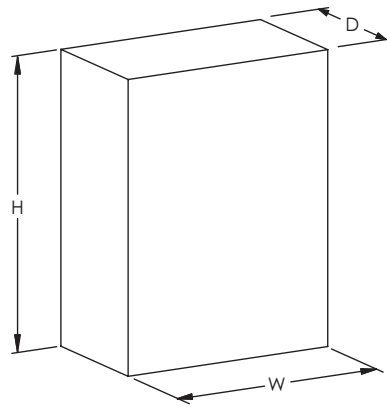

Features

- Uses a hybrid Transient Voltage Surge Suppression (TVSS) filter device that incorporates TD technology
- Capacitive filtering and voltage dependent metal oxide varistors provide high-energy surge suppression
- Active parallel filter removes common disturbances in electrical environment
- Flying lead monitors status of surge suppression components in each phase

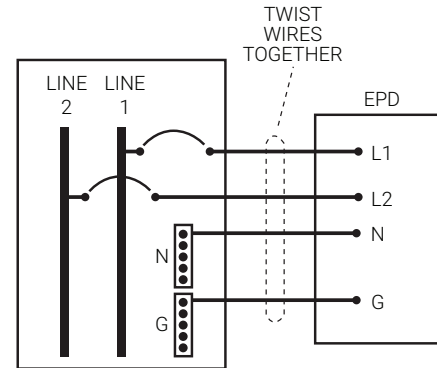

Part Number	EPD120240TDFL
Nominal System Voltage (Un)	120/240 V
Max Continuous Operating Voltage (Uc)	150/300 VAC
Stand-off Voltage	240/480 VAC
Frequency	50 – 60 Hz
Aggregate Surge Rating	206 kA 8/20 μ s
Voltage Protection Level (Up)	600 V @ 10 kA L-N; 870 V @ 20 kA L-N; 450 V @ 3 kA L-N; 400 V @ 500 A
Short Circuit Current Rating (SCCR)	200 kA
Filtering	-40 dB @ 100 kHz
Lead Length	24"
Lead Size	#12
Distribution System	1Ph 3W+G
Protection Modes	L-N; L-PE
Status Indication	LED
Technology	TD technology with EMI/RFI filter
Mounting	1/2" straight nipple
Humidity	0 – 90 % RH
Temperature	-40 to 158 °F
Enclosure Material	Metal
Enclosure Rating	NEMA®-1
Depth (D)	4.3"
Height (H)	6.3"
Width (W)	6.3"
Unit Weight	6 lb
Complies With	ANSI®/IEEE® C62.41.2-2002 Cat A, Cat B, Cat C; ANSI®/IEEE® C62.41.2-2002 Scenario II, Exposure 2, 50 kA 8/20 μ s; AREMA® requirements

Rail Secondary Power Surge Protector, AC Circuits

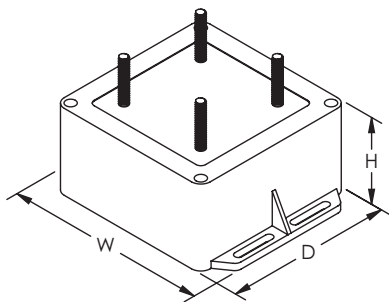

Features

- Transient Discriminating (TD) technology helps ensure safe operation during abnormal over-voltage events
- Hybrid TVSS technology
- Low let-through voltage
- Sine wave filter for RFI/EMI attenuation

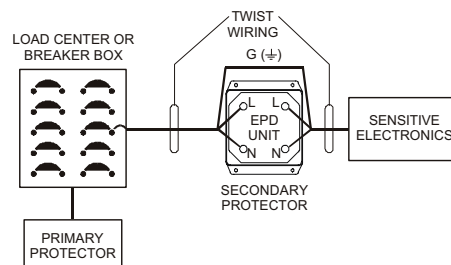

Part Number	EPD120TDAARB
Nominal System Voltage (Un)	120 V
Max Continuous Operating Voltage (Uc)	150 VAC
Rated Load Current (IL)	30 A
Frequency	50 – 60 Hz
Filtering	-65 dB @ 100 kHz
Aggregate Surge Rating	20 kA 8/20 μ s
Distribution System	1Ph 2W+G
Protection Modes	L-N
Technology	TD technology with thermal disconnect; EMI/RFI filter
Connection Type	AAR Terminals
Status Indication	LED
Humidity	0 – 90 % RH
Temperature	-40 to 158 °F
Enclosure Material	UL® 94V-0 Thermoplastic
Enclosure Rating	IP 20; NEMA®-1
Depth (D)	4 3/4"
Height (H)	2 3/8"
Width (W)	5 3/4"
Unit Weight	2.5 lb
Complies With	ANSI®/IEEE® C62.41.2-2002 Cat A, Cat B, Cat C
Standard Packaging Quantity	1 pc

Rail Secondary Power Surge Protector, DC Circuits

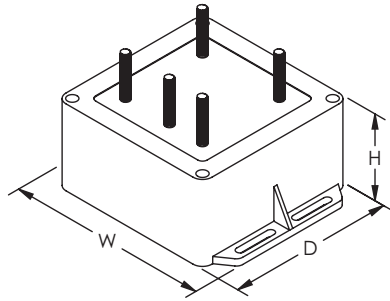

Features

- Hybrid TVSS technology
- High surge rating provides a high level of protection and long operational life
- Internal patented thermal disconnect system designed specifically for operation of DC systems to assist safe disconnect at end of life
- Low let-through voltage
- Sine wave filter for RFI/EMI attenuation

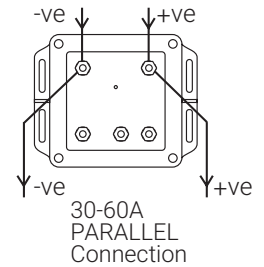
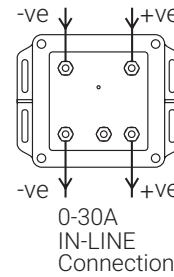

Part Number	EPD1224ATAAR1
Nominal System Voltage (Un)	12 VDC; 24 VDC
Max Continuous Operating Voltage (Uc), 12 VDC	18 VDC
Max Continuous Operating Voltage (Uc), 24 VDC	36 VDC
Voltage Protection Level, 12 VDC (Up)	34 V @ 20 kA
Voltage Protection Level, 24 VDC (Up)	41 V @ 20 kA
Rated Load Current (IL)	30 A; 60 A
Filtering	-65 dB @ 100 kHz
Distribution System	Two wire
Aggregate Surge Rating	20 kA 8/20 μs
Status Indication	LED
Technology	Metal Oxide Varistor (MOV); Silicon Avalanche Diode (SAD); In-line series filter
Connection Type	AAR Terminals
Protection Modes	-ve to +ve
Humidity	0 – 90 % RH
Temperature	-40 to 158 °F
Enclosure Material	UL® 94V-0 Thermoplastic
Enclosure Rating	IP 20; NEMA®-1
Depth (D)	4.73"
Height (H)	2.37"
Width (W)	4.73"
Unit Weight	1.92 lb
Complies With	ANSI®/IEEE® C62.41.2-2002 Cat A, Cat B, Cat C; AREMA® requirements

DT and EDT SPD Features

Packed with features and benefits for the user, the DT and EDT line from nVent ERICO represents the latest in product design, development and testing.



ADVANCED DESIGN AVOIDS FUSING IN MANY INSTALLATIONS

SPD STATUS INDICATION

ALARM CONTACTS ALLOW REMOTE STATUS MONITORING



CLIP LOCKS MODULE IN PLACE FOR VIBRATION RESISTANCE



CONVENIENT MODULE AND BASE DESIGN

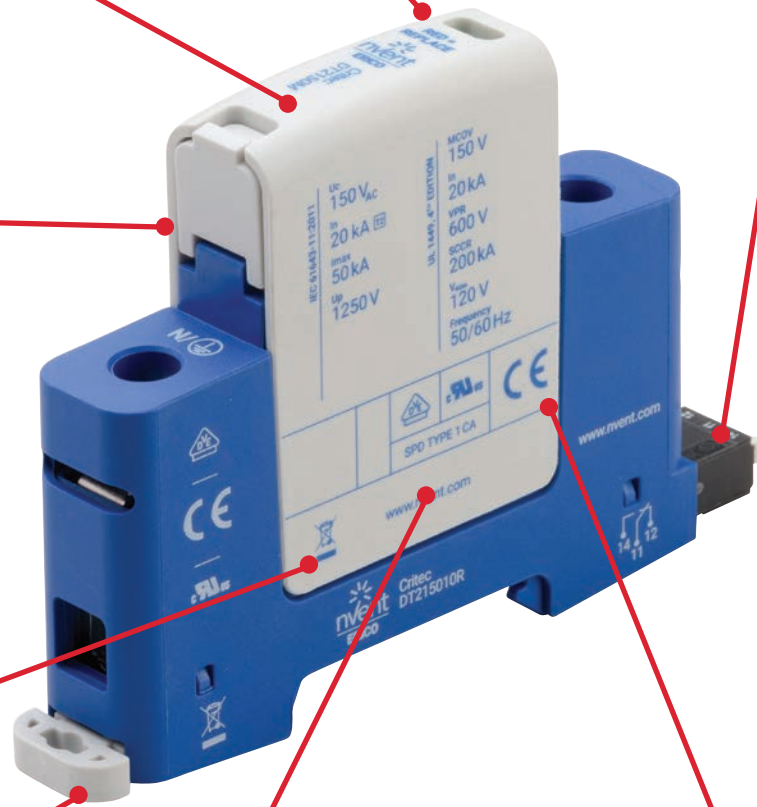

LOCK BACK CLIP MAKES FOR EASY INSTALLATION



KEYING MECHANISM ENSURES CORRECT MODULE

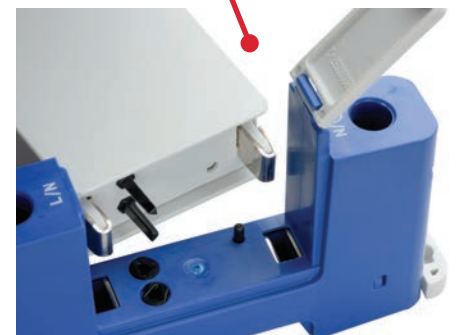

RUGGED CONNECTION TO BASE HANDLES HIGH SURGE CURRENT

DT1 Din Rail Surge Protection IEC Class I+II, 1+0 Mode

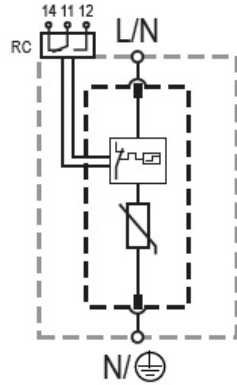

Features

- Compact, yet high surge rated pluggable design, using minimum DIN rail width
- Retaining clip ensures enhanced vibration and shock resistance performance
- Red/Green status indication and change-over contacts standard for remote monitoring

Certification Details: IEC 61643-11 Class I+II, EN 61643-11 Type 1+2, UL 1449, 4th Edition Type 1CA

Complies with: IEC 61643-11:2011, EN 61643-11:2012, UL 1449, 4th Edition, CSA C22.2 No. 269-4

Protection Modes: L-PE, N-PE (only TN-S), L-PE/N, L-N, L-L



Part Number	DT17510R	DT115010R	DT130010R	DT135010R	DT148010R	DT175010R
UL Electrical						
UL Nominal Voltage	60V	120V	240V	277V	400V	600V
Maximum Continuous Operating Voltage (AC) MCOV	75V	150V	300V	350V	480V	750V
Voltage Protection Rating VPR	330V	500V	900V	1200V	1500V	2500V
Nominal Discharge Current (8/20 μ s) I_n	20 kA	20 kA	20 kA	20 kA	20 kA	20 kA
Short-Circuit Current Rating (AC) SCCR	100 kA	200 kA	150 kA	150 kA	200 kA	150 kA
IEC Electrical						
Nominal AC Voltage (50/60Hz) U_o / U_n	60V	120V	240V	277V	400V	600V
Maximum Continuous Operating Voltage (AC) U_c	75V	150V	300V	350V	480V	750V
Nominal Discharge Current (8/20 μ s) I_n	20 kA					
Maximum Discharge Current (8/20 μ s) I_{max}	50 kA	50 kA	50 kA	50 kA	50 kA	35 kA
Impulse Discharge Current (10/350 μ s) I_{imp}	12.5 kA	12.5kA	12.5 kA	12.5 kA	10 kA	5 kA
Specific Energy W/R	39 kJ/Q	39 kJ/Q	39 kJ/Q	39 kJ/Q	25 kJ/Q	6.25 kJ/Q
Charge Q	6.25 As	6.25 As	6.25 As	6.25 As	5 As	2.5 As
Voltage Protection Level U_p	700V	1000V	1400V	1500V	2000V	2700V
Response Time t_A	< 25 ns					
Back-Up Fuse (max)	315A / 250A gG					250A gG
Short-Circuit Current Rating (AC) I_{SCCR}	25 kA / 50 kA					50 kA
TOV Withstand 5s U_T	114V	175V	337V	403V	581V	871V
TOV 120 min $U_{T(mode)}$	114V/withstand	229V/safe fail	442V/safe fail	529V/safe fail	762V/safe fail	1143/safe fail
Number of Ports	1					
Mechanical						
Operating Temperature Range T_a	-31 F to 185 F (-35 C to 85 C)					
Permissible Operating Humidity RH	5%...95%					
Altitude	6562 ft [2000 m]					
Terminal Screw Torque M_{max}	39.9 lbf.in [4.5 Nm]					
Conductor Cross Section (max)	35mm ² (Solid) / 25mm ² (Stranded) , 2 AWG (Solid) / 4 AWG (Stranded)					
Mounting	35 mm DIN Rail, EN 60715					
Degree of Protection	IP 20					
Housing Material	Thermoplastic: Extinguishing Degree UL 94 V-0					
Thermal Protection	Yes					
Operating State / Fault Indication	Green Flag / Not Green Flag					
Remote Contacts (RC)	Yes					
RC Switching Capacity	AC: 250V/ 1A, 125V/ 1A; DC: 48V/0.5A, 24V/0.5A, 12V/0.5A					
RC Conductor Cross Section (max)	1.5mm ² (Solid) / 16 AWG (Solid)					
Single Unit Weight pounds	0.371	0.371	0.402	0.437	0.446	0.452
Single Unit Weight grams	168	168	182	198	202	205

*Other voltages and configurations available upon request

DT1 DIN Rail Surge Protection IEC Class I+II, 2+0 Mode

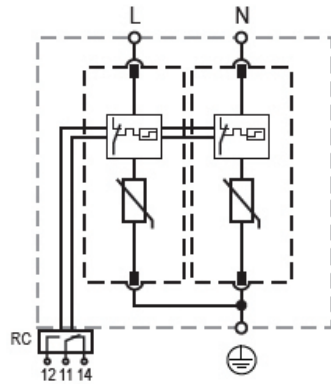

Features

- Compact, yet high surge rated pluggable design, using minimum DIN rail width
- Retaining clip ensures enhanced vibration and shock resistance performance
- Red/Green status indication and change-over contacts standard for remote monitoring

Certification Details:	IEC 61643-11 Class I+II EN 61643-11 Type 1+2 UL 1449, 4th Edition Type 1CA
Complies with:	IEC 61643-11:2011 EN 61643-11:2012 UL 1449, 4th Edition CSA C22.2 No. 269-4
Protection Modes:	L-PE, N-PE, L-L



Part Number	DT115020R	DT130020R	DT135020R	DT175020R
UL Electrical				
UL Nominal Voltage	240/120V 1S 208/120V 3Y	415/240V 3Y 240V 3D	480/277V 3Y 240V 3D	347/600V 3Y
Maximum Continuous Operating Voltage (AC) MCOV	150V/300V	300V/600V	350V/700V	750V/1500V
Voltage Protection Rating VPR	500V/1000V	900V/1800V	1200V/2000V	2500V/5000V
Nominal Discharge Current (8/20 μ s) I_n	20 kA	20 kA	20 kA	20 kA
Short-Circuit Current Rating (AC) SCCR	200 kA	150 kA	150 kA	150 kA
IEC Electrical				
Nominal AC Voltage (50/60Hz) U_o / U_n	120V	240V	277V	600V
Maximum Continuous Operating Voltage (AC) U_c	150V	300V	350V	750V
Nominal Discharge Current (8/20 μ s) I_n	20 kA			
Maximum Discharge Current (8/20 μ s) I_{max}	50 kA	50 kA	50 kA	35 kA
Impulse Discharge Current (10/350 μ s) I_{imp}	12.5kA	12.5 kA	12.5 kA	5 kA
Specific Energy W/R	39 kJ/ Ω	39 kJ/ Ω	39 kJ/ Ω	6.25 kJ/ Ω
Charge Q	6.25 As	6.25 As	6.25 As	2.5 As
Voltage Protection Level U_p	1000V	1400V	1500V	2700V
Response Time t_A	< 25 ns			
Back-Up Fuse (max)	315A / 250A gG			250A gG
Short-Circuit Current Rating (AC) ISCCR	25 kA / 50 kA			50 kA
TOV Withstand 5s U_T	175V	337V	403V	871V
TOV 120 min U_{Tmode}	229V/safe fail	442V/safe fail	529V/safe fail	1143/safe fail
Number of Ports	1			
Mechanical				
Operating Temperature Range T_a	-31 F to 185 F (-35 C to 85 C)			
Permissible Operating Humidity RH	5%...95%			
Altitude	6562 ft [2000 m]			
Terminal Screw Torque M_{max}	39.9 lbf-in [4.5 Nm]			
Conductor Cross Section (max)	35mm ² (Solid) / 25mm ² (Stranded), 2 AWG (Solid) / 4 AWG (Stranded)			
Mounting	35 mm DIN Rail, EN 60715			
Degree of Protection	IP 20			
Housing Material	Thermoplastic: Extinguishing Degree UL 94 V-0			
Thermal Protection	Yes			
Operating State / Fault Indication	Green Flag / Not Green Flag			
Remote Contacts (RC)	Yes			
RC Switching Capacity	AC: 250V/ 1A, 125V/ 1A; DC: 48V/0.5A, 24V/0.5A, 12V/0.5A			
RC Conductor Cross Section (max)	1.5mm ² (Solid) / 16 AWG (Solid)			
Single Unit Weight pounds	0.717	0.779	0.849	0.880
Single Unit Weight grams	325	353	385	399

*Other voltages and configurations available upon request

DT1 DIN Rail Surge Protection IEC Class I+II, 3+0 Mode

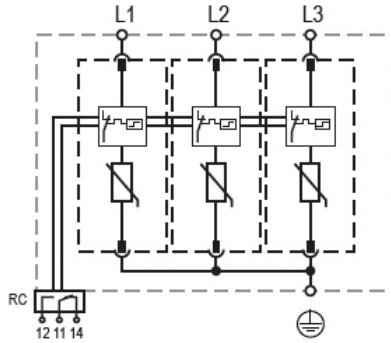

Features

- Compact, yet high surge rated pluggable design, using minimum DIN rail width
- Retaining clip ensures enhanced vibration and shock resistance performance
- Red/Green status indication and change-over contacts standard for remote monitoring

Certification Details: IEC 61643-11 Class I+II
EN 61643-11 Type 1+2
UL 1449, 4th Edition Type 1CA

Complies with: IEC 61643-11:2011
EN 61643-11:2012
UL 1449, 4th Edition
CSA C22.2 No. 269-4

Protection Modes: L-PE, N-PE, L-L



Part Number	DT115030R	DT130030R	DT135030R	DT148030R	DT175030R
UL Electrical					
UL Nominal Voltage	208/120V 3Y 240/120V 1S	415/240 3Y 240V 3D	480/277V 3Y	690/400V 3Y	600V 3D 480V 3D
Maximum Continuous Operating Voltage (AC) MCOV	150V/300V	300V/600V	350V/700V	480V/960V	750V/1500V
Voltage Protection Rating VPR	500V/1000V	900V/1800V	1200V/2000V	1500V/3000V	2500V/5000V
Nominal Discharge Current (8/20 μ s) I_n	20 kA	20 kA	20 kA	20 kA	20 kA
Short-Circuit Current Rating (AC) SCCR	200 kA	150 kA	150 kA	200 kA	150 kA
IEC Electrical					
Nominal AC Voltage (50/60Hz) U_o / U_n	120V	240V	277V	400V	600V
Maximum Continuous Operating Voltage (AC) U_c	150V	300V	350V	480V	750V
Nominal Discharge Current (8/20 μ s) I_n	20 kA				
Maximum Discharge Current (8/20 μ s) I_{max}	50 kA	50 kA	50 kA	50 kA	35 kA
Impulse Discharge Current (10/350 μ s) I_{imp}	12.5kA	12.5 kA	12.5 kA	10 kA	5 kA
Specific Energy W/R	39 kJ/Q	39 kJ/Q	39 kJ/Q	25 kJ/Q	6.25 kJ/Q
Charge Q	6.25 As	6.25 As	6.25 As	5 As	2.5 As
Voltage Protection Level U_p	1000V	1400V	1500V	2000V	2700V
Response Time t_A	< 25 ns				
Back-Up Fuse (max)	315A / 250A gG				250A gG
Short-Circuit Current Rating (AC) I_{SCCR}	25 kA / 50 kA				50 kA
TOV Withstand 5s U_T	175V	337V	403V	581V	871V
TOV 120 min U_{Tmode}	229V/safe fail	442V/safe fail	529V/safe fail	762V/safe fail	1143/safe fail
Number of Ports	1				
Mechanical					
Operating Temperature Range T_a	-31 F to 185 F (-35 C to 85 C)				
Permissible Operating Humidity RH	5%...95%				
Altitude	6562 ft [2000 m]				
Terminal Screw Torque M_{max}	39.9 lbf in [4.5 Nm]				
Conductor Cross Section (max)	35mm ² (Solid) / 25mm ² (Stranded), 2 AWG (Solid) / 4 AWG (Stranded)				
Mounting	35 mm DIN Rail, EN 60715				
Degree of Protection	IP 20				
Housing Material	Thermoplastic: Extinguishing Degree UL 94 V-0				
Thermal Protection	Yes				
Operating State / Fault Indication	Green Flag / Not Green Flag				
Remote Contacts (RC)	Yes				
RC Switching Capacity	AC: 250V/ 1A, 125V/ 1A; DC: 48V/0.5A, 24V/0.5A, 12V/0.5A				
RC Conductor Cross Section (max)	1.5mm ² (Solid) / 16 AWG (Solid)				
Single Unit Weight pounds	1.041	1.133	1.239	1.266	1.286
Single Unit Weight grams	472	514	562	574	583

*Other voltages and configurations available upon request

DT1 DIN Rail Surge Protection IEC Class I+II, 4+0 Mode

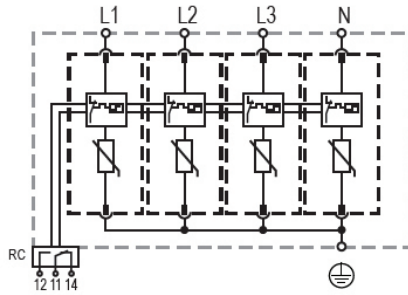

Features

- Compact, yet high surge rated pluggable design, using minimum DIN rail width
- Retaining clip ensures enhanced vibration and shock resistance performance
- Red/Green status indication and change-over contacts standard for remote monitoring

Certification Details: IEC 61643-11 Class I+II
EN 61643-11 Type 1+2
UL 1449, 4th Edition Type 1CA

Complies with: IEC 61643-11:2011
EN 61643-11:2012
UL 1449, 4th Edition
CSA C22.2 No. 269-4

Protection Modes: L-PE, N-PE, L-L



Part Number	DT115040R	DT130040R	DT135040R	DT148040R
UL Electrical				
UL Nominal Voltage	208/120V 3Y	415/240 3Y	480/277V 3Y	690/400V 3Y
Maximum Continuous Operating Voltage (AC) MCOV	150V/300V	300V/600V	350V/700V	480V/960V
Voltage Protection Rating VPR	500V/1000V	900V/1800V	1200V/2000V	1500V/2500V
Nominal Discharge Current (8/20 μ s) I_n	20 kA	20 kA	20 kA	20 kA
Short-Circuit Current Rating (AC) SCCR	200 kA	150 kA	150 kA	200 kA
IEC Electrical				
Nominal AC Voltage (50/60Hz) U_o / U_n	120V	240V	277V	400V
Maximum Continuous Operating Voltage (AC) U_c	150V	300V	350V	480V
Nominal Discharge Current (8/20 μ s) I_n	20 kA			
Maximum Discharge Current (8/20 μ s) I_{max}	50 kA	50 kA	50 kA	50 kA
Impulse Discharge Current (10/350 μ s) I_{imp}	12.5kA	12.5 kA	12.5 kA	10 kA
Specific Energy W/R	39 kJ/ Ω	39 kJ/ Ω	39 kJ/ Ω	25 kJ/ Ω
Charge Q	6.25 As	6.25 As	6.25 As	5 As
Voltage Protection Level U_p	1000V	1400V	1500V	2000V
Response Time t_A	< 25 ns			
Back-Up Fuse (max)	315A / 250A gG			
Short-Circuit Current Rating (AC) I_{SCCR}	25 kA / 50 kA			
TOV Withstand 5s UT	175V	337V	403V	581V
TOV 120 min U_{Tmode}	229V/safe fail	442V/safe fail	529V/safe fail	762V/safe fail
Number of Ports	1			
Mechanical				
Operating Temperature Range T_a	-31 F to 185 F (-35 C to 85 C)			
Permissible Operating Humidity RH	5%...95%			
Altitude	6562 ft [2000 m]			
Terminal Screw Torque M_{max}	39.9 lbf-in [4.5 Nm]			
Conductor Cross Section (max)	35mm ² (Solid) / 25mm ² (Stranded), 2 AWG (Solid) / 4 AWG (Stranded)			
Mounting	35 mm DIN Rail, EN 60715			
Degree of Protection	IP 20			
Housing Material	Thermoplastic: Extinguishing Degree UL 94 V-0			
Thermal Protection	Yes			
Operating State / Fault Indication	Green Flag / Not Green Flag			
Remote Contacts (RC)	Yes			
RC Switching Capacity	AC: 250V/ 1A, 125V/ 1A; DC: 48V/0.5A, 24V/0.5A, 12V/0.5A			
RC Conductor Cross Section (max)	1.5mm ² (Solid) / 16 AWG (Solid)			
Single Unit Weight pounds	1.396	1.519	1.661	1.696
Single Unit Weight grams	633	689	753	769

*Other voltages and configurations available upon request

DT2 DIN Rail Surge Protection IEC Class II, 1+0 Mode

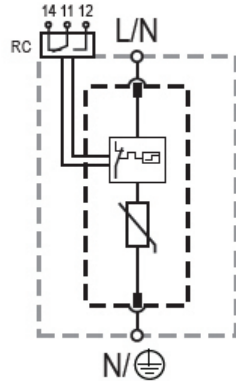

Features

- Compact, yet high surge rated pluggable design, using minimum DIN rail width
- Retaining clip ensures enhanced vibration and shock resistance performance
- Red/Green status indication and change-over contacts standard for remote monitoring

Certification Details: IEC 61643-11 Class I+II
EN 61643-11 Type 1+2
UL 1449, 4th Edition Type 1CA

Complies with: IEC 61643-11:2011
EN 61643-11:2012
UL 1449, 4th Edition
CSA C22.2 No. 269-4

Protection Modes: L-N, N-PE, L-L



Part Number	DT27510R	DT215010R	DT230010R	DT235010R	DT248010R	DT275010R
UL Electrical						
UL Nominal Voltage	60V	120V	240V	277V	400V	600V
Maximum Continuous Operating Voltage (AC) MCOV	75V	150V	300V	350V	480V	750V
Voltage Protection Rating VPR	330V	600V	900V	1000V	1500V	2500V
Nominal Discharge Current (8/20 μ s) I_n	20 kA					
Short-Circuit Current Rating (AC) SCCR	100 kA	200 kA	150 kA	200 kA	200 kA	200 kA
IEC Electrical						
Nominal AC Voltage (50/60Hz) U_o / U_n	60V	120V	240V	277V	400V	600V
Maximum Continuous Operating Voltage (AC) U_c	75V	150V	300V	350V	480V	750V
Nominal Discharge Current (8/20 μ s) I_n	20 kA					
Maximum Discharge Current (8/20 μ s) I_{max}	50 kA	50 kA	50 kA	50 kA	50 kA	35 kA
Voltage Protection Level U_p	800V	1250V	1500V	1750V	2300V	3400V
Response Time t_A	< 25 ns					
Back-Up Fuse (max)	315A / 250A gG					
Short-Circuit Current Rating (AC) I_{SCCR}	25 kA / 50 kA					
TOV Withstand 5s U_T	114V	229V	337V	403V	581V	871V
TOV 120 min U_{Tmode}	114V/withstand	229V/safe fail	442V/safe fail	529V/safe fail	762V/safe fail	1143/safe fail
Number of Ports	1					
Mechanical						
Operating Temperature Range T_a	-31 F to 185 F (-35 C to 85 C)					
Permissible Operating Humidity RH	5%...95%					
Altitude	6562 ft [2000 m]					
Terminal Screw Torque M_{max}	39.9 lbf-in [4.5 Nm]					
Conductor Cross Section (max)	35mm ² (Solid) / 25mm ² (Stranded), 2 AWG (Solid) / 4 AWG (Stranded)					
Mounting	35 mm DIN Rail, EN 60715					
Degree of Protection	IP 20					
Housing Material	Thermoplastic: Extinguishing Degree UL 94 V-0					
Thermal Protection	Yes					
Operating State / Fault Indication	Green Flag / Not Green Flag					
Remote Contacts (RC)	Yes					
RC Switching Capacity	AC: 250V/ 1A, 125V/ 1A; DC: 48V/0.5A, 24V/0.5A, 12V/0.5A					
RC Conductor Cross Section (max)	1.5mm ² (Solid) / 16 AWG (Solid)					
Single Unit Weight pounds	0.274	0.283	0.298	0.309	0.320	0.355
Single Unit Weight grams	124	128	135	140	145	161

*Other voltages and configurations available upon request

DT2 DIN Rail Surge Protection IEC Class II, 2+0 Mode

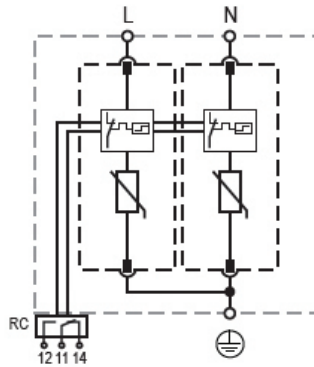

Features

- Compact, yet high surge rated pluggable design, using minimum DIN rail width
- Retaining clip ensures enhanced vibration and shock resistance performance
- Red/Green status indication and change-over contacts standard for remote monitoring

Certification Details: IEC 61643-11 Class II
EN 61643-11 Type 2
UL 1449, 4th Edition Type 1CA

Complies with: IEC 61643-11:2011
EN 61643-11:2012
UL 1449, 4th Edition
CSA C22.2 No. 269-4

Protection Modes: L-PE, N-PE, L-L



Part Number	DT27520R	DT215020R	DT230020R	DT235020R	DT275020R
UL Electrical					
UL Nominal Voltage	60V	240/120V 1S 208/120V 3Y	415/240V 3Y 240V 3D	480/277V 3Y 240V 3D	690/400V 3Y 600V 3D
Maximum Continuous Operating Voltage (AC) MCOV	75V/150V	150V/300V	300V/600V	350V/700V	750V/1500V
Voltage Protection Rating VPR	330V/700V	600V/1000V	900V/1800V	1000V/2000V	2500V/5000V
Nominal Discharge Current (8/20 μ s) I_n	20 kA				
Short-Circuit Current Rating (AC) SCCR	100 kA	200 kA	150 kA	200 kA	200 kA
IEC Electrical					
Nominal AC Voltage (50/60Hz) U_o / U_n	60V	120V	240V	277V	600V
Maximum Continuous Operating Voltage (AC) U_c	75V	150V	300V	350V	750V
Nominal Discharge Current (8/20 μ s) I_n	20 kA				
Maximum Discharge Current (8/20 μ s) I_{max}	50 kA	50 kA	50 kA	50 kA	35 kA
Voltage Protection Level U_p	800V	1250V	1500V	1750V	3400V
Response Time t_A	< 25 ns				
Back-Up Fuse (max)	315A / 250A gG				
Short-Circuit Current Rating (AC) I_{SCCR}	25 kA / 50 kA				
TOV Withstand 5s U_T	114V	229V	337V	403V	871V
TOV 120 min U_{Tmode}	114V/withstand	229V/withstand	442V/safe fail	529V/safe fail	1143/safe fail
Number of Ports	1				
Mechanical					
Operating Temperature Range T_a	-31 F to 185 F (-35 C to 85 C)				
Permissible Operating Humidity RH	5%...95%				
Altitude	6562 ft [2000 m]				
Terminal Screw Torque M_{max}	39.9 lbf-in [4.5 Nm]				
Conductor Cross Section (max)	35mm ² (Solid) / 25mm ² (Stranded), 2 AWG (Solid) / 4 AWG (Stranded)				
Mounting	35 mm DIN Rail, EN 60715				
Degree of Protection	IP 20				
Housing Material	Thermoplastic: Extinguishing Degree UL 94 V-0				
Thermal Protection	Yes				
Operating State / Fault Indication	Green Flag / Not Green Flag				
Remote Contacts (RC)	Yes				
RC Switching Capacity	AC: 250V/ 1A, 125V/ 1A; DC: 48V/0.5A, 24V/0.5A, 12V/0.5A				
RC Conductor Cross Section (max)	1.5mm ² (Solid) / 16 AWG (Solid)				
Single Unit Weight pounds	0.538	0.556	0.587	0.609	0.702
Single Unit Weight grams	244	252	266	276	318

*Other voltages and configurations available upon request

DT2 DIN Rail Surge Protection IEC Class II, 3+0 Mode

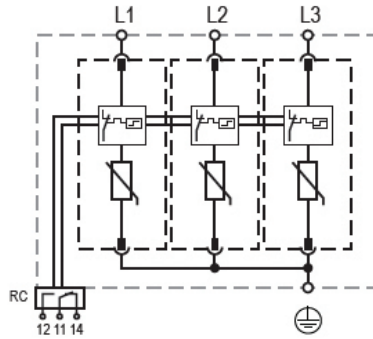

Features

- Compact, yet high surge rated pluggable design, using minimum DIN rail width
- Retaining clip ensures enhanced vibration and shock resistance performance
- Red/Green status indication and change-over contacts standard for remote monitoring

Certification Details: IEC 61643-11 Class II
EN 61643-11 Type 2
UL 1449, 4th Edition Type 1CA

Complies with: IEC 61643-11:2011
EN 61643-11:2012
UL 1449, 4th Edition
CSA C22.2 No. 269-4

Protection Modes: L-PE/N, L-L



Part Number	DT215030R	DT230030R	DT235030R	DT248030R	DT275030R
UL Electrical					
UL Nominal Voltage	208/120V 3Y 240/120V 1S	415/240 3Y 240V 3D	480/277V 3Y	690/400V 3Y	600V 3D
Maximum Continuous Operating Voltage (AC) MCOV	150V/300V	300V/600V	350V/700V	480V/960V	750V/1500V
Voltage Protection Rating VPR	600V/1000V	900V/1800V	1000V/2000V	1500V/3000V	2500V/5000V
Nominal Discharge Current (8/20 μ s) I_n	20 kA				
Short-Circuit Current Rating (AC) SCCR	200 kA	150 kA	200 kA	200 kA	200 kA
IEC Electrical					
Nominal AC Voltage (50/60Hz) U_o / U_n	120V	240V	277V	400V	600V
Maximum Continuous Operating Voltage (AC) U_c	150V	300V	350V	480V	750V
Nominal Discharge Current (8/20 μ s) I_n	20 kA				
Maximum Discharge Current (8/20 μ s) I_{max}	50 kA				
Voltage Protection Level U_p	1250V	1500V	1750V	2300V	3400V
Response Time t_A	< 25 ns				
Back-Up Fuse (max)	315A / 250A gG				
Short-Circuit Current Rating (AC) I_{SCCR}	25 kA / 50 kA				
TOV Withstand 5s U_T	229V	337V	403V	581V	871V
TOV 120 min $U_{T(mode)}$	229V/withstand	442V/safe fail	529V/safe fail	762V/safe fail	1143/safe fail
Number of Ports	1				
Mechanical					
Operating Temperature Range T_a	-31 F to 185 F (-35 C to 85 C)				
Permissible Operating Humidity RH	5%...95%				
Altitude	6562 ft [2000 m]				
Terminal Screw Torque M_{max}	39.9 lbf-in [4.5 Nm]				
Conductor Cross Section (max)	35mm ² (Solid) / 25mm ² (Stranded), 2 AWG (Solid) / 4 AWG (Stranded)				
Mounting	35 mm DIN Rail, EN 60715				
Degree of Protection	IP 20				
Housing Material	Thermoplastic: Extinguishing Degree UL 94 V-0				
Thermal Protection	Yes				
Operating State / Fault Indication	Green Flag / Not Green Flag				
Remote Contacts (RC)	Yes				
RC Switching Capacity	AC: 250V/ 1A, 125V/ 1A; DC: 48V/0.5A, 24V/0.5A, 12V/0.5A				
RC Conductor Cross Section (max)	1.5mm ² (Solid) / 16 AWG (Solid)				
Single Unit Weight pounds	0.783	0.829	0.862	0.896	1.001
Single Unit Weight grams	355	376	391	406	454

*Other voltages and configurations available upon request

DT2 DIN Rail Surge Protection IEC Class II, 4+0 Mode

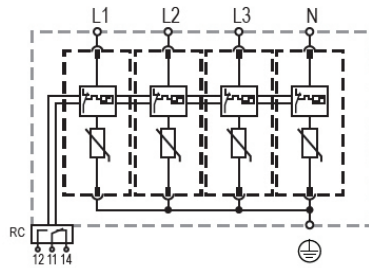

Features

- Compact, yet high surge rated pluggable design, using minimum DIN rail width
- Retaining clip ensures enhanced vibration and shock resistance performance
- Red/Green status indication and change-over contacts standard for remote monitoring

Certification Details:	IEC 61643-11 Class I+II EN 61643-11 Type 1+2 UL 1449, 4th Edition Type 1CA
Complies with:	IEC 61643-11:2011 EN 61643-11:2012 UL 1449, 4th Edition CSA C22.2 No. 269-4
Protection Modes:	L-PE, N-PE, L-L



Part Number	DT215040R	DT230040R	DT235040R	DT248040R
UL Electrical				
UL Nominal Voltage	208/120V 3Y	415/240 3Y	480/277V 3Y	690/400V 3Y
Maximum Continuous Operating Voltage (AC) MCOV	150V/300V	300V/600V	350V/700V	480V/960V
Voltage Protection Rating VPR	600V/1000V	900V/1800V	1000V/2000V	1500V/3000V
Nominal Discharge Current (8/20 μ s) I_n	20 kA			
Short-Circuit Current Rating (AC) SCCR	200 kA	150 kA	200 kA	200 kA
IEC Electrical				
Nominal AC Voltage (50/60Hz) U_o / U_n	120V	240V	277V	400V
Maximum Continuous Operating Voltage (AC) U_c	150V	300V	350V	480V
Nominal Discharge Current (8/20 μ s) I_n	20 kA			
Maximum Discharge Current (8/20 μ s) I_{max}	50 kA			
Voltage Protection Level U_p	1250V	1500V	1750V	2300V
Response Time t_A	< 25 ns			
Back-Up Fuse (max)	315A / 250A gG			
Short-Circuit Current Rating (AC) I_{SCCR}	25 kA / 50 kA			
TOV Withstand 5s U_T	229V	337V	403V	581V
TOV 120 min $U_{T(mode)}$	229V/withstand	442V/safe fail	529V/safe fail	762V/safe fail
Number of Ports	1			
Mechanical				
Operating Temperature Range T_a	-31 F to 185 F (-35 C to 85 C)			
Permissible Operating Humidity RH	5%...95%			
Altitude	6562 ft [2000 m]			
Terminal Screw Torque M_{max}	39.9 lbf-in [4.5 Nm]			
Conductor Cross Section (max)	35mm ² (Solid) / 25mm ² (Stranded), 2 AWG (Solid) / 4 AWG (Stranded)			
Mounting	35 mm DIN Rail, EN 60715			
Degree of Protection	IP 20			
Housing Material	Thermoplastic: Extinguishing Degree UL 94 V-0			
Thermal Protection	Yes			
Operating State / Fault Indication	Green Flag / Not Green Flag			
Remote Contacts (RC)	Yes			
RC Switching Capacity	AC: 250V/ 1A, 125V/ 1A; DC: 48V/0.5A, 24V/0.5A, 12V/0.5A			
RC Conductor Cross Section (max)	1.5mm ² (Solid) / 16 AWG (Solid)			
Single Unit Weight pounds	1.052	1.114	1.158	1.202
Single Unit Weight grams	477	505	525	545

*Other voltages and configurations available upon request

EDT2 Enhanced Din Rail Surge Protection

IEC Class II, 1+0 Mode

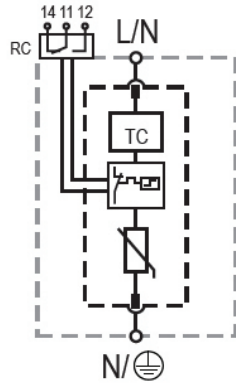

Features

- Compact, yet high surge rated pluggable design, using minimum DIN rail width
- Retaining clip ensures enhanced vibration and shock resistance performance
- Red/Green status indication and change-over contacts standard for remote monitoring

Certification Details: IEC 61643-11 Class I+II
EN 61643-11 Type 1+2
UL 1449, 4th Edition Type 1CA

Complies with: IEC 61643-11:2011
EN 61643-11:2012
UL 1449, 4th Edition
CSA C22.2 No. 269-4

Protection Modes: L-N, N-PE, L-L



Part Number	EDT27510R	EDT215010R	EDT230010R	EDT235010R	EDT248010R	EDT255010R	EDT275010R
UL Electrical							
UL Nominal Voltage	60V	120V	240V	277V	400V	480V	600V
Maximum Continuous Operating Voltage (AC) MCOV	75V	150V	300V	350V	480V	550V	750V
Voltage Protection Rating VPR	600V	700V	1200V	1200V	1500V	1800V	2500V
Nominal Discharge Current (8/20 μ s) I_n	20 kA						
Short-Circuit Current Rating (AC) SCCR	85 kA	200 kA	150 kA	200 kA	200 kA	200 kA	200 kA
IEC Electrical							
Nominal AC Voltage (50/60Hz) U_o / U_n	60V	120V	240V	277V	400V	480V	600V
Maximum Continuous Operating Voltage (AC) U_c	75V	150V	300V	350V	480V	550V	750V
Nominal Discharge Current (8/20 μ s) I_n	20 kA						
Maximum Discharge Current (8/20 μ s) I_{max}	50 kA						
Voltage Protection Level U_p	800V	1250V	1650V	1750V	2300V	2500V	3500V
Response Time t_A	< 25 ns						
Back-Up Fuse (max)	315A / 250A gG						
Short-Circuit Current Rating (AC) I_{SCCR}	25 kA / 50 kA						
TOV Withstand 120 min U_T	150V	300V	442V	529V	762V	918V	1200V
Number of Ports	1						
Mechanical							
Operating Temperature Range T_a	-31 F to 185 F (-35 C to 85 C)						
Permissible Operating Humidity RH	5%...95%						
Altitude	6562 ft [2000 m]						
Terminal Screw Torque M_{max}	39.9 lbf-in [4.5 Nm]						
Conductor Cross Section (max)	35mm ² (Solid) / 25mm ² (Stranded), 2 AWG (Solid) / 4 AWG (Stranded)						
Mounting	35 mm DIN Rail, EN 60715						
Degree of Protection	IP 20						
Housing Material	Thermoplastic: Extinguishing Degree UL 94 V-0						
Thermal Protection	Yes						
Operating State / Fault Indication	Green Flag / Not Green Flag						
Remote Contacts (RC)	Yes						
RC Switching Capacity	AC: 250V/ 1A, 125V/ 1A; DC: 48V/0.5A, 24V/0.5A, 12V/0.5A						
RC Conductor Cross Section (max)	1.5mm ² (Solid) / 16 AWG (Solid)						
Single Unit Weight pounds	0.287	0.296	0.307	0.325	0.331	0.342	0.364
Single Unit Weight grams	130	134	139	147	150	155	165

*Other voltages and configurations available upon request

EDT2 Enhanced DIN Rail Surge Protection IEC Class II, 2+0 Mode

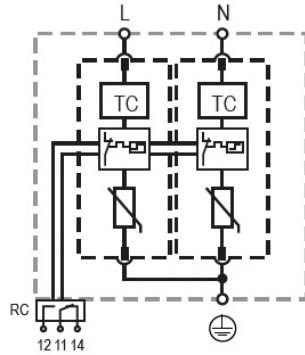

Features

- Includes nVent ERICO TD Technology to ensure reliability throughout adverse voltage conditions
- Enhanced temporary over voltage (TOV) withstand capability
- Compact, yet high surge rated pluggable design, using minimum DIN rail width
- Retaining clip ensures enhanced vibration and shock resistance performance
- Red/Green status indication and change-over contacts standard for remote monitoring

Certification Details: UL® 1449 Edition 4 Type 1CA

Complies with: EN 61643-11 Type 2
IEC® 61643-11 Class II

Protection Modes: L-N, N-PE, L-L



Part Number	EDT215020R	EDT230020R	EDT235020R	EDT248020R	EDT255020R	EDT275020R
UL Electrical						
UL Nominal Voltage	208/120V 3Y 240/120V 1S	415/240V 3Y 240V 3D	480/277V 3Y 240V 3D	690/400V 3Y	690/400V 3Y 480V 3D	600V 3D
Maximum Continuous Operating Voltage (AC) MCOV	150V/300V	300V/600V	350V/700V	480V/960V	550V/1100V	750V/1500V
Voltage Protection Rating VPR	600V/1200V	1200V/1800V	1200V/2000V	1500V/3000V	1800V/3000V	2500V/5000V
Nominal Discharge Current (8/20 μ s) I_n	20 kA					
Short-Circuit Current Rating (AC) SCCR	200 kA	150 kA	200 kA	200 kA	200 kA	200 kA
IEC Electrical						
Nominal AC Voltage (50/60Hz) U_o / U_n	120V	240V	277V	400V	400V	600V
Maximum Continuous Operating Voltage (AC) U_c	150V	300V	350V	480V	550V	750V
Nominal Discharge Current (8/20 μ s) I_n	20 kA					
Maximum Discharge Current (8/20 μ s) I_{max}	50 kA					35 kA
Voltage Protection Level U_p	1250V	1650V	1750V	2300V	2500V	3500V
Response Time t_A	< 25 ns					
Back-Up Fuse (max)	315A / 250A gG					
Short-Circuit Current Rating (AC) I_{SCCR}	25 kA / 50 kA					
TOV Withstand 120 min U_T	300V	442V	529V	762V	918V	1200V
Number of Ports	1					
Mechanical						
Operating Temperature Range T_a	-31 F to 185 F (-35 C to 85 C)					
Permissible Operating Humidity RH	5%...95%					
Altitude	6562 ft [2000 m]					
Terminal Screw Torque M_{max}	39.9 lbf.in [4.5 Nm]					
Conductor Cross Section (max)	35mm ² (Solid) / 25mm ² (Stranded), 2 AWG (Solid) / 4 AWG (Stranded)					
Mounting	35 mm DIN Rail, EN 60715					
Degree of Protection	IP 20					
Housing Material	Thermoplastic: Extinguishing Degree UL 94 V-0					
Thermal Protection	Yes					
Operating State / Fault Indication	Green Flag / Not Green Flag					
Remote Contacts (RC)	Yes					
RC Switching Capacity	AC: 250V/ 1A, 125V/ 1A; DC: 48V/0.5A, 24V/0.5A, 12V/0.5A					
RC Conductor Cross Section (max)	1.5mm ² (Solid) / 16 AWG (Solid)					
Single Unit Weight pounds	0.583	0.605	0.640	0.653	0.675	0.719
Single Unit Weight grams	264	274	290	296	306	326

*Other voltages and configurations available upon request

EDT2 Enhanced DIN Rail Surge Protection IEC Class II, 3+0 Mode

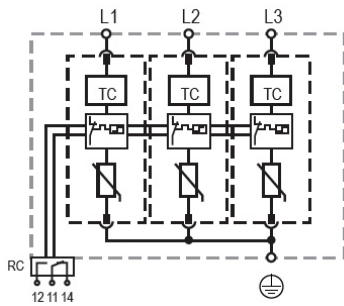

Features

- Compact, yet high surge rated pluggable design, using minimum DIN rail width
- Retaining clip ensures enhanced vibration and shock resistance performance
- Red/Green status indication and change-over contacts standard for remote monitoring

Certification Details:	IEC 61643-11 Class II EN 61643-11 Type 2 UL 1449, 4th Edition Type 1CA
Complies with:	IEC 61643-11:2011 EN 61643-11:2012 UL 1449, 4th Edition CSA C22.2 No. 269-4
Protection Modes:	L-PE/N, L-L



Part Number	EDT215030R	EDT230030R	EDT235030R	EDT248030R	EDT255030R	EDT275030R
UL Electrical						
UL Nominal Voltage	208/120V 3Y 240/120V 1S	415/240 3Y 240V 3D	480/277V 3Y	690/400V 3Y	480V 3D	600V 3D
Maximum Continuous Operating Voltage (AC) MCOV	150V/300V	300V/600V	350V/700V	480V/960V	550V/1100V	750V/1500V
Voltage Protection Rating VPR	700V/1500V	1200V/2000V	1200V/2000V	1500V/2500V	1800V/3000V	2500V/5000V
Nominal Discharge Current (8/20 μ s) I_n	20 kA					
Short-Circuit Current Rating (AC) SCCR	200 kA	150 kA	200 kA	200 kA	200 kA	200 kA
IEC Electrical						
Nominal AC Voltage (50/60Hz) U_o / U_n	120V	240V	277V	400V	400V	600V
Maximum Continuous Operating Voltage (AC) U_c	150V	300V	350V	480V	550V	750V
Nominal Discharge Current (8/20 μ s) I_n	20 kA					
Maximum Discharge Current (8/20 μ s) I_{max}	50 kA					
Voltage Protection Level U_p	1250V	1650V	1750V	2300V	2500V	3500V
Response Time t_A	< 25 ns					
Back-Up Fuse (max)	315A / 250A gG					
Short-Circuit Current Rating (AC) I_{SCCR}	25 kA / 50 kA					
TOV Withstand 120 min U_T	300V	442V	529V	762V	918V	1200V
Number of Ports	1					
Mechanical						
Operating Temperature Range T_a	-31 F to 185 F (-35 C to 85 C)					
Permissible Operating Humidity RH	5%...95%					
Altitude	6562 ft [2000 m]					
Terminal Screw Torque M_{max}	39.9 lbf-in [4.5 Nm]					
Conductor Cross Section (max)	35mm ² (Solid) / 25mm ² (Stranded), 2 AWG (Solid) / 4 AWG (Stranded)					
Mounting	35 mm DIN Rail, EN 60715					
Degree of Protection	IP 20					
Housing Material	Thermoplastic: Extinguishing Degree UL 94 V-0					
Thermal Protection	Yes					
Operating State / Fault Indication	Green Flag / Not Green Flag					
Remote Contacts (RC)	Yes					
RC Switching Capacity	AC: 250V/ 1A, 125V/ 1A; DC: 48V/0.5A, 24V/0.5A, 12V/0.5A					
RC Conductor Cross Section (max)	1.5mm ² (Solid) / 16 AWG (Solid)					
Single Unit Weight pounds	0.823	0.856	0.909	0.929	0.962	1.028
Single Unit Weight grams	373	388	412	421	436	466

*Other voltages and configurations available upon request

EDT2 Enhanced DIN Rail Surge Protection

IEC Class II, 4+0 Mode

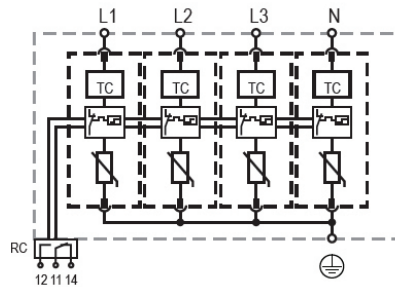

Features

- Compact, yet high surge rated pluggable design, using minimum DIN rail width
- Retaining clip ensures enhanced vibration and shock resistance performance
- Red/Green status indication and change-over contacts standard for remote monitoring

Certification Details: IEC 61643-11 Class II
EN 61643-11 Type 2
UL 1449, 4th Edition Type 1CA

Complies with: IEC 61643-11:2011
EN 61643-11:2012
UL 1449, 4th Edition
CSA C22.2 No. 269-4

Protection Modes: L-PE, N-PE, L-L



Part Number	EDT215040R	EDT230040R	EDT235040R	EDT248040R	EDT255040R
UL Electrical					
UL Nominal Voltage	208/120V 3Y	415/240 3Y	480/277V 3Y	690/400V 3Y	690/400V 3Y
Maximum Continuous Operating Voltage (AC) MCOV	150V/300V	300V/600V	350V/700V	480V/960V	550V/1100V
Voltage Protection Rating VPR	600V/1000V	1200V/2000V	1200V/2000V	1500V/2500V	1800V/3000V
Nominal Discharge Current (8/20 μ s) I_n	20 kA				
Short-Circuit Current Rating (AC) SCCR	200 kA	150 kA	200 kA	200 kA	200 kA
IEC Electrical					
Nominal AC Voltage (50/60Hz) U_o / U_n	120V	240V	277V	400V	400V
Maximum Continuous Operating Voltage (AC) U_c	150V	300V	350V	480V	550V
Nominal Discharge Current (8/20 μ s) I_n	20 kA				
Maximum Discharge Current (8/20 μ s) I_{max}	50 kA				
Voltage Protection Level U_p	1250V	1650V	1750V	2300V	2500V
Response Time t_A	< 25 ns				
Back-Up Fuse (max)	315A / 250A gG				
Short-Circuit Current Rating (AC) I_{SCCR}	25 kA / 50 kA				
TOV Withstand 120 min U_T	300V	442V	529V	762V	918V
Number of Ports	1				
Mechanical					
Operating Temperature Range T_a	-31 F to 185 F (-35 C to 85 C)				
Permissible Operating Humidity RH	5%...95%				
Altitude	6562 ft [2000 m]				
Terminal Screw Torque M_{max}	39.9 lbf-in [4.5 Nm]				
Conductor Cross Section (max)	35mm ² (Solid) / 25mm ² (Stranded), 2 AWG (Solid) / 4 AWG (Stranded)				
Mounting	35 mm DIN Rail, EN 60715				
Degree of Protection	IP 20				
Housing Material	Thermoplastic: Extinguishing Degree UL 94 V-0				
Thermal Protection	Yes				
Operating State / Fault Indication	Green Flag / Not Green Flag				
Remote Contacts (RC)	Yes				
RC Switching Capacity	AC: 250V/ 1A, 125V/ 1A; DC: 48V/0.5A, 24V/0.5A, 12V/0.5A				
RC Conductor Cross Section (max)	1.5mm ² (Solid) / 16 AWG (Solid)				
Single Unit Weight pounds	1.105	1.149	1.220	1.246	1.290
Single Unit Weight grams	501	521	553	565	585

*Other voltages and configurations available upon request

PVT1 Photovoltaic Surge Protection Class I

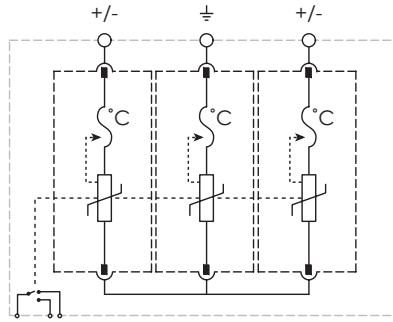

Features

- Uniquely designed for protection of centralized solar inverters on the DC input side and string boxes
- Thermal protection included to ensure safe failure modes
- Compact, yet high surge rated pluggable design, using minimum DIN rail width



Part Number	PVT11000R	PVT11500R
Max Continuous Operating Voltage (Ucpv)	1,100 V	1,500 VDC
Nominal Discharge Current (In), IEC	20 kA 8/20 μ s	
Impulse Current (Iimp)	6.25 kA 10/350 μ s	5.00 kA 10/350 μ s
Total Discharge Current (Itotal)	12.5 kA 10/350 μ s; 50.0 kA 8/20 μ s	10.0 kA 10/350 μ s; 40.0 kA 8/20 μ s
Voltage Protection Level (Up)	4,000 V	5,000 V
Response Time	25 ns Max	
Short Circuit Current Rating (Iscrr)	11 kA	
Max Continuous Operating Voltage (Vpvdc)	1,100 VDC	1,500 VDC
Voltage Protection Rating (VPR)	2,500 V	4,000 V
Nominal Discharge Current (In), UL	20 kA 8/20 μ s	
Short Circuit Current Rating (SCCR)	50 kA	65 kA
Protection Modes	-ve to PE; -ve to +ve; +ve to PE	
Altitude	6,562' Max	
Humidity	5 – 95 % RH	
Temperature	-40 F to 185 F (-40 C to 85 C)	
Connection, Flexible	#4	
Connection, Solid	#2	
Connection, Stranded	#2	
Enclosure Material	UL® 94V-0 Thermoplastic	
Enclosure Rating	IP 20	
Mounting	35 mm top hat DIN rail	
Torque (TQ)	3.3 ft lb Max	
Remote Contact Switching Capacity	1.0 A @ 125 VAC; 1.0 A @ 250 VAC; 0.5 A @ 12 VDC; 0.5 A @ 24 VDC; 0.5 A @ 48 VDC	
Remote Contacts	Yes	
Status Indication	Mechanical flag	
Depth (D)	3.35"	
Height (H)	3.54"	
Width (W)	2.13"	
Unit Weight	1.02 lb	1.10 lb
Replacement Module	PVT1500M; PVT1500SM	PVT1750M; PVT1750SM
Certification Details	UL® 1449 Edition 4 Type 1CA	
Complies With	EN 50539-11 Type 1, Type 2	

PVT2 Photovoltaic Surge Protection Class II

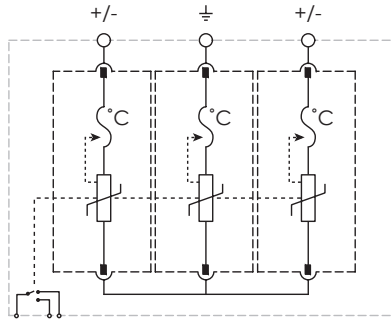

Features

- Suited for use at the DC input of distributed string inverters in solar arrays
- Thermal protection included to ensure safe failure modes
- Compact, yet high surge rated pluggable design, using minimum DIN rail width



Part Number	PVT21000R	PVT21500R
Max Continuous Operating Voltage (Ucpv)	1,100 V	1,500 VDC
Nominal Discharge Current (In), IEC	20 kA 8/20 μ s	
Max Discharge Current (Imax)	40 kA 8/20 μ s	30 kA 8/20 μ s
Total Discharge Current (Itotal)	50 kA 8/20 μ s	40 kA 8/20 μ s
Voltage Protection Level (Up)	4,000 V	5,000 V
Response Time	25 ns Max	
Short Circuit Current Rating (Iscrr)	11 kA	
Max Continuous Operating Voltage (Vpvdc)	1,100 VDC	1,500 VDC
Voltage Protection Rating (VPR)	3,000 V	4,000 V
Nominal Discharge Current (In), UL	20 kA 8/20 μ s	
Short Circuit Current Rating (SCCR)	50 kA	65 kA
Protection Modes	-ve to PE; -ve to +ve; +ve to PE	
Altitude	6,562' Max	
Humidity	5 – 95 % RH	
Temperature	-40 F to 185 F (-40 C to 85 C)	
Connection, Flexible	#4	
Connection, Solid	#2	
Connection, Stranded	#2	
Enclosure Material	UL® 94V-0 Thermoplastic	
Enclosure Rating	IP 20	
Mounting	35 mm top hat DIN rail	
Torque (TQ)	3.3 ft lb Max	
Remote Contact Switching Capacity	1.0 A @ 125 VAC; 1.0 A @ 250 VAC; 0.5 A @ 12 VDC; 0.5 A @ 24 VDC; 0.5 A @ 48 VDC	
Remote Contacts	Yes	
Status Indication	Mechanical flag	
Depth (D)	2.72"	
Height (H)	3.54"	
Width (W)	2.13"	
Unit Weight	0.9 lb	1.0 lb
Replacement Module	PVT2500M	PVT2750M
Certification Details	UL® 1449 Edition 4 Type 1CA	
Complies With	EN 50539-11 Type 1, Type 2	

Transient Discriminating Surge Diverter, 20 kA Three Mode

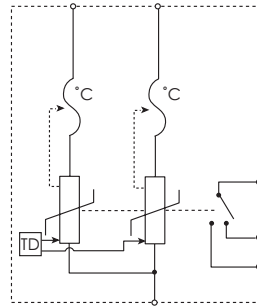
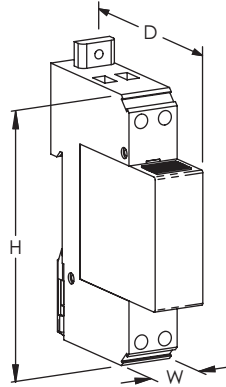

Features

- 20 kA 8/20 μ s surge rating provides robust surge protection
- TD Technology with thermal disconnect protection
- Compact package, modular DIN rail mounting for limited space requirements
- Three modes of protection: L-N, L-PE and N-PE
- Indication flags and voltage-free contacts provide remote status monitoring
- Separate plug and base design facilitates replacement of a failed surge module



Part Number	TDS1301T150	TDS1301T240	TDS1301TR150	TDS1301TR240
Nominal System Voltage (Un)	120 - 150 VAC	220 - 240 VAC	120 - 150 VAC	220 - 240 VAC
Max Continuous Operating Voltage (Uc)	170 VAC	275 VAC	170 VAC	275 VAC
Stand-off Voltage	230 VAC	440 VAC	230 VAC	440 VAC
Voltage Protection Rating (VPR)	800 V @ 3 kA L-N 500 V @ 3 kA L+N-PE	1,500 V @ 3 kA L-N 800 V @ 3 kA L+N-PE	800 V @ 3 kA L-N 500 V @ 3 kA L+N-PE	1,500 V @ 3 kA L-N 800 V @ 3 kA L+N-PE
Nominal Discharge Current (In), Per Mode	8 kA 8/20 μ s			
Max Discharge Current (Imax)	20 kA 8/20 μ s L-N, 20 kA 8/20 μ s L-PE			
Back-Up Overcurrent Protection	63 A			
Short Circuit Current Rating (SCCR)	200 kA			
Frequency	0 – 100 Hz			
Protection Modes	L-N L-PE N-PE			
Response Time	5 ns Max			
Technology	TD technology with thermal disconnect			
Connection, PE Solid	#2 Max			
Connection, PE Stranded	#4 Max			
Connection, Solid	#10 Max			
Connection, Stranded	#10 Max			
Mounting	35 mm top hat DIN rail			
Enclosure Material	UL® 94V-0 Thermoplastic			
Enclosure Rating	IP 20 NEMA®-1			
Remote Contacts	No		Yes	
Status Indication	Mechanical flag			
Temperature	-40 to 176 °F			
Module Width	1 M			
Depth (D)	2.68"			
Height (H)	3.54"			
Width (W)	0.71"			
Unit Weight	0.26 lb			
Certification Details	UL® 1449 Edition 4, Type 4CA			
Complies With	ANSI®/IEEE® C62.41.2-2002 Cat A, Cat B IEC® 61643-1 Class III			
Replacement Module	TDS130M150	TDS130M240	TDS130M150	TDS130M240

Surge Diverter, 24/48 DC

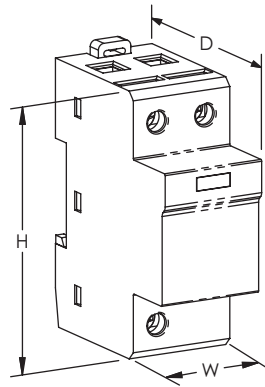

Features

- 40 kA 8/20 μ s surge rating per mode, 80 kA per line, 120 kA total per pair
- Suitable for exposed DC wiring
- Indication flag provides clear visual indication of life status
- Suitable for both 24 VDC and 48 VDC distribution systems

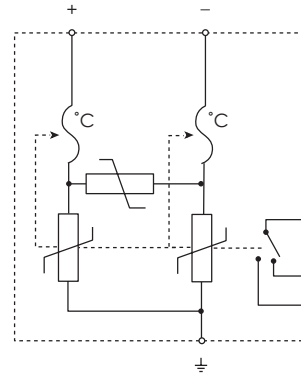

Part Number	DSD1402BR24/48
Nominal System Voltage (Un)	0 - 48 VDC
Max Continuous Operating Voltage (Uc)	60 VAC; 60 VDC
Max Discharge Current (Imax), Per Mode	40 kA 8/20 μ s
Nominal Discharge Current (In)	20 kA 8/20 μ s
Voltage Protection Level (Up), + to - @ In	600 V
Voltage Protection Level (Up), L-N	280 V @ 3 kA
Frequency	0 - 60 Hz
Protection Modes	Common Differential
Short Circuit Current Rating (SCCR)	25 kA
Technology	MOV with thermal disconnect
Connection, Solid	#2 Max
Connection, Stranded	#4 Max
Mounting	35 mm top hat DIN rail
Enclosure Material	UL [®] 94V-0 Thermoplastic
Enclosure Rating	IP 20 NEMA [®] -1
Status Indication	Mechanical flag
Terminal Torque	31 ft lb Max
Remote Contacts	Yes
Temperature	-40 to 176 °F
Module Width	2 M
Depth (D)	2.68"
Part Number	DSD1402BR24/48
Height (H)	3.54"
Width (W)	1.42"
Unit Weight	0.45 lb
Complies With	ANSI [®] /IEEE [®] C62.41.2-2002 Cat A, Cat B, Cat C; ANSI [®] /IEEE [®] C62.41.2-2002 Scenario II, Exposure 2, 20 kA 8/20 μ s, 2 kA 10/350 μ s IEC [®] 61643-1 Class II
Certifications	CE, DSD140; Qualifoudre
Standard Packaging Quantity	1 pc
UPC	78285652474
EAN-13	8711893029802

Transient Surge Filter

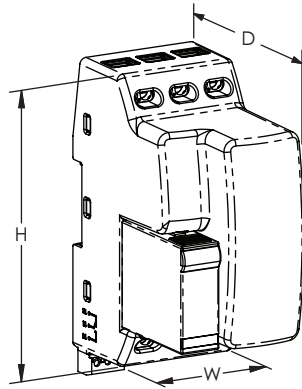

Features

- Compact, space saving design
- Replaceable surge module reduces down time and unprotected time during maintenance
- Compliance to the latest UL 1449 Edition 4 and IEC 61643-11 surge standards and UL 1283 Electromagnetic Interference Filters (EMI) standard
- Low let-through voltages on the critical line to neutral mode
- Transient Discriminating (TD) Technology provides increased service life
- All modes protected at 20 kA 8/20 μ s
- Form C Relay Contacts for Remote Monitoring
- Two Terminals per line

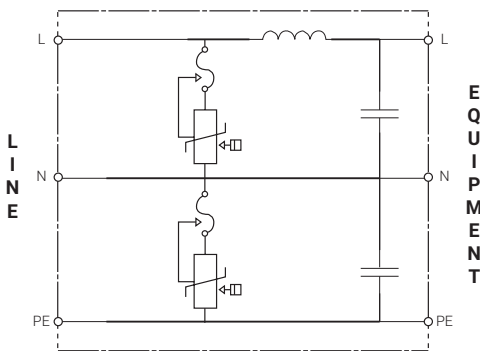

Specification	TSF6A24V	TSF6A120V	TSF20A120V	TSF6A240V	TSF20A240V
Nominal System Voltage (U_n)	24 V	120 V		240 V	
Rated Load Current (I_L)	6 A		20 A	6 A	20 A
Max Continuous Operating Voltage (U_c)	30 VAC/38 VDC	170 V		275 V	
Stand-off Voltage	–	230		440	
Filtering	-65 dB @ 100 kHz		-50 dB @ 100 kHz	-65 dB @ 100 kHz	-50 dB @ 100 kHz
Frequency	0 – 100 Hz				
Max Discharge Current (I_{max})	20 kA 8/20 μ s, all modes				
Voltage Protection Rating (VPR) L-N	–	330v	400v	–	–
Measured Limiting Voltage (MLV) L-N	–	–	–	620v	680v
Nominal Discharge Current (I_n)	3 kA 8/20 μ s, all modes				
Distribution System	1Ph 2W+G				
Connection, Solid	2.5 mm ² - 6.0 mm ² ; #14 - #10				
Connection, Stranded	2.5 mm ² - 6.0 mm ² ; #14 - #10				
Mounting	35 mm top hat DIN rail				
Status Indication	Mechanical flag				
Enclosure Material	UL [®] 94V-0 Thermoplastic				
Enclosure Rating	IP 20				
Temperature	-31 – 104 °F				
Module Width	3 M				
Depth (D) x Height (H) x Width (W)	95 mm x 123 mm x 54 mm				
Unit Weight	508 grams				
Replacement Module	TSF24MDS	TSF120MTDS		TSF240MTDS	
Certifications	CE	CE, cURus, UL 1449 Ed 4, UL 1283 Ed 5			

Surge Reduction Filter N-Series, Single Phase

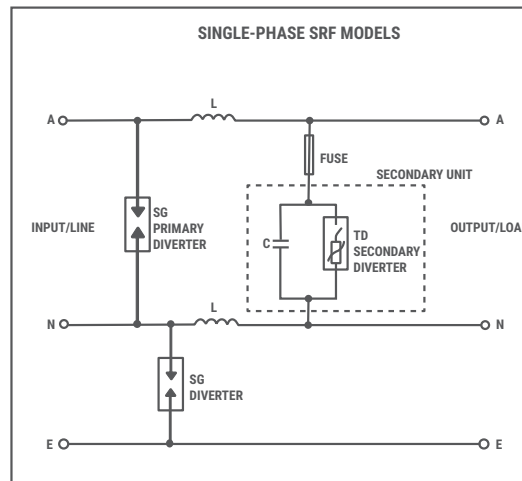
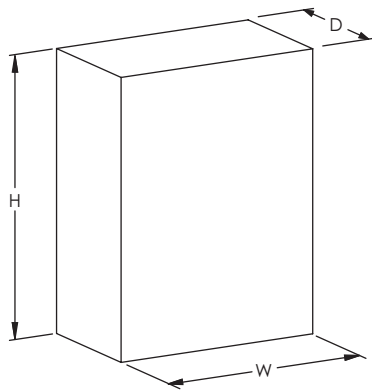

Features

- High-performance protection incorporating Spark Gap and Transient Discriminating (TD) technologies
- High surge rating ideal for exposed critical service entrance applications
- Reduces let-through voltages and rate-of-voltage rise (dv/dt) and helps provide optimum protection for electronic equipment
- Extreme reliability and simplified design with direct connection from input to output
- Comprehensive front panel status and internal diagnostic LEDs



Specification	SRF163N	SRF1125N
Nominal System Voltage (Un)	220 - 240 VAC	
Distribution System	1Ph 2W+G	
System Compatibility	TN-C, TN-C-S, TN-S, TT	
Frequency	50 – 60 Hz	
Short Circuit Current Rating (SCCR)	43 kA	
Heat Dissipation	25 W	
Filtering	-40 dB @ 100 kHz	
Protection Modes	All modes protected	
Technology	Spark Gap, In-line series low pass sine wave filter, TD technology with thermal disconnect (50 kA 8/20us secondary stage)	
Enclosure Material	Metal	
Enclosure Rating	IP 65	
Mounting	Wall mount	
Status Indication	Front panel LED, Internal diagnostic primary and secondary protection LEDs, Change-over contact (Form C dry), 250 VAC/30 VDC/5 A, 4 kV isolation	
Rated Load Current (IL)	63 A	125 A
Rate of Voltage Rise (dV/dt)	3 V/μs Max	8 V/μs Max
Input Connection	10 - 35 mm ²	25 - 120 mm ²
Output Connection	25 - 120 mm ²	
Depth (D)	200 mm	
Height (H)	300 mm	
Width (W)	400 mm	
Unit Weight	10.3 kg	12.3 kg
Complies With	IEC® 61643-11 Class I, Class II ANSI®/IEEE® C62.41.2-2002 Cat A, Cat B, Cat C ANSI®/IEEE® C62.41.2-2002 Scenario II, Exposure 3, 100 kA 8/20 μs, 10 kA 10/350 μs	

Surge Reduction Filter N-Series, Three Phase

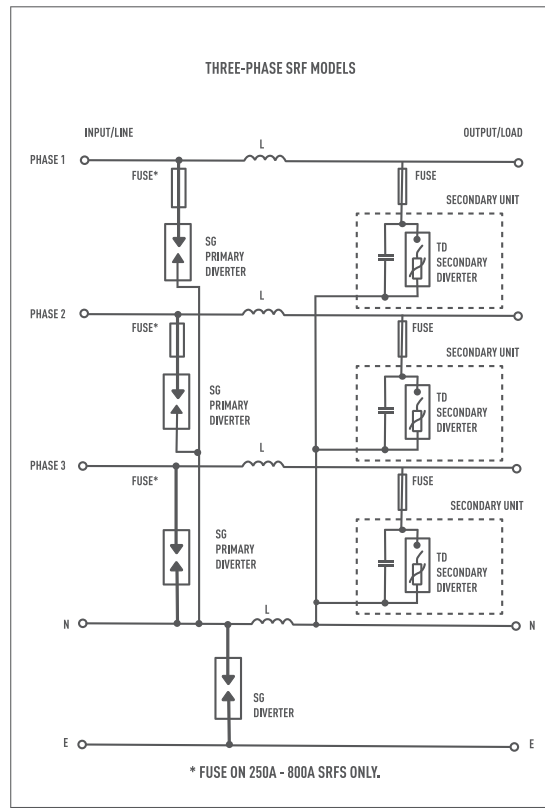
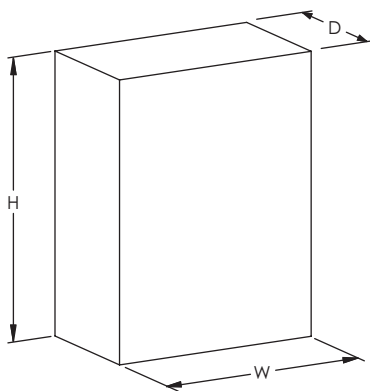

Features

- High-performance protection incorporating Spark Gap and Transient Discriminating (TD) technologies
- High surge rating ideal for exposed critical service entrance applications
- Reduces let-through voltages and rate-of-voltage rise (dv/dt) and helps provide optimum protection for electronic equipment
- Extreme reliability and simplified design with direct connection from input to output
- Comprehensive front panel status and internal diagnostic LEDs



Specification	SRF363N	SRF3125N	SRF3250N	SRF3500N	SRF3800N
Nominal System Voltage (Un)	220/380 - 240/415 VAC				
Distribution System	3Ph Y 4W+G				
System Compatibility	TN-C, TN-C-S, TN-S, TT				
Frequency:	50 – 60 Hz				
Short Circuit Current Rating (SCCR)	43 kA				
Filtering	-40 dB @ 100 kHz				
Protection Modes	All modes protected				
Technology	Spark Gap, In-line series low pass sine wave filter, TD technology with thermal disconnect (50 kA 8/20us secondary stage)				
Enclosure Material	Metal				
Mounting	Wall mount				
Status Indication	Front panel LED, Internal diagnostic primary and secondary protection LEDs, Change-over contact (Form C dry), 250 VAC/30 VDC/5 A, 4 kV isolation				
Rated Load Current (IL)	63 A	125 A	250 A	500 A	800 A
Heat Dissipation	34 W	56 W	98 W	215 W	260 W
Rate of Voltage Rise (dV/dt)	5 V/μs Max	10 V/μs Max	11 V/μs Max	10 V/μs Max	
Input Connection	10 - 35 mm ²	25 - 120 mm ²		10 mm Stud	(2) 10 mm studs
Output Connection	10 - 35 mm ²	25 - 120 mm ²		10 mm Stud	(2) 10 mm studs
Enclosure Rating	IP 65			IP 32	
Depth (D)	200 mm			300 mm	
Height (H)	500 mm		800 mm	1000 mm	1200 mm
Width (W)	400 mm		600 mm	800 mm	
Unit Weight	17.7 kg	21.6 kg	41.7 kg	76.6 kg	97.2 kg
Complies With	IEC® 61643-11 Class I, Class II ANSI®/IEEE® C62.41.2-2002 Cat A, Cat B, Cat C ANSI®/IEEE® C62.41.2-2002 Scenario II, Exposure 3, 100 kA 8/20 μs, 10 kA 10/350 μs				

High Speed Data Line Protector

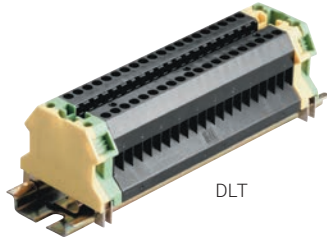
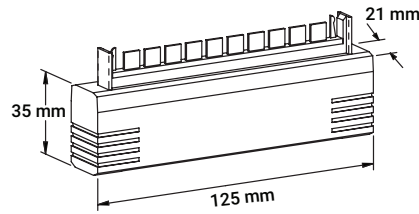

DLT

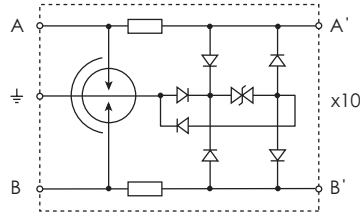

Features

- Multi-stage protection with primary or combination primary/secondary protectors
- 10 pair protector
- Provides both L-L and L-PE protection modes for comprehensive protection Simple installation into Krone® LSA disconnect block
- Data Line Terminator (DLT) available where screw terminal connections are required



Specification	HSP10K12	HSP10K36	HSP10K72	HSP10K230
Max Continuous Operating Voltage (Uc)	13 VDC	40 VDC	65 VDC	190 VDC
Max Discharge Current (Imax), L+L-PE	20 kA 8/20 μs			
Rated Load Current (IL)	150 mA			
Frequency	12 MHz Max			
Transmission Rate	8 Mb/s			
Protection Modes	L-L, L-PE			
Technology	Multi-stage			
Connection Type	Krone® LSA-PLUS			
Impedance Balance	55 dB Max			
Insertion Loss	.4 dB Max			
Return Loss	20 dB Max			
Certifications	UL 497B			

Subscriber Line Protector, Single Stage

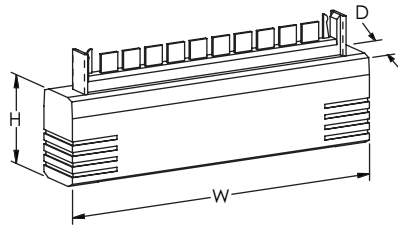
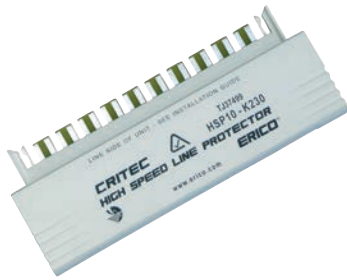

Features

- Single stage protection with primary or combination primary/secondary protectors
- 10 pair protector
- Simple installation into Krone® LSA disconnect block
- Data Line Terminator (DLT) available where screw terminal connections are required

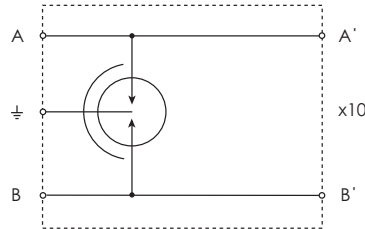
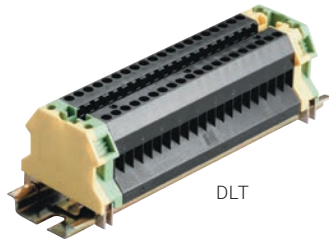

Specification	SLP10K1F
Max Continuous Operating Voltage (Uc)	190 VDC
Max Discharge Current (Imax), L+L-PE	20 kA 8/20 μs
Rated Load Current (IL)	1,000 mA
Frequency	12 Hz Max
Transmission Rate	8 Mb/s
Protection Modes	L-L
Technology	Single-stage
Connection Type	Krone® LSA-PLUS
Impedance Balance	48 dB Max
Insertion Loss	.75 dB Max
Return Loss	22 dB Max
Loop Resistance	0.2 Ω
Temperature	-20 to 60 °C
Enclosure Material	UL® 94V-0 Thermoplastic
Depth (D)	21 mm
Height (H)	34.5 mm
Width (W)	125 mm
Unit Weight	22.7 g
Certification Details	UL 497B
Certifications	RCM, CE, cULus
Standard Packaging Quantity	1 pc
UPC	78285647508
EAN-13	9321098000460

Telephone Line Protector

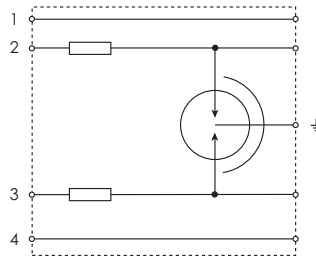
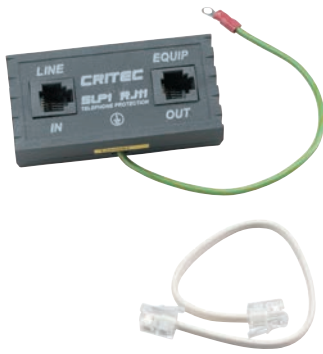

Features

- RJ11 sockets provide simple plug-in connection for 4 or 6 position RJ plugs
- Includes patch cord and adhesive mounting strips
- Provides both L-L and L-PE protection modes for comprehensive protection
- Automatic over-current protection



Specification	SLP1RJ11	SLP1RJ11A
Max Continuous Operating Voltage (Uc)	280 V	
Max Discharge Current (Imax), Per Mode	500 A 8/20 μ s	20 kA 8/20 μ s
Voltage Protection Level (Up), T-R	110 V	
Voltage Protection Level (Up), T/R-G	500 V @ 125 A	
Rated Load Current (IL)	160 mA	120 mA
Connection Type	RJ11	
Ground Lead Length	6"	
Lead Size	#18	
Temperature	-40 F to 149 F	
Depth (D)	1.1"	
Height (H)	1 1/2"	
Width (W)	3.06"	3.05"
Unit Weight	0.11 lb	
Enclosure Material	UL [®] 94V-0 Thermoplastic	
Certifications	UL 497A	RCM, NOM

Coaxial Surge Protector

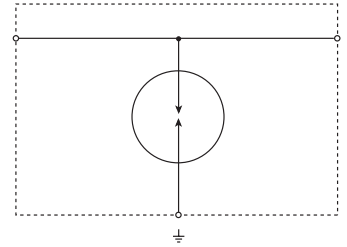
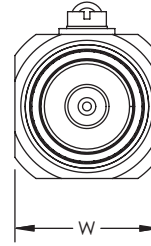
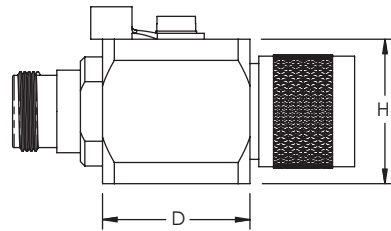

SPECIFICATIONS

Max Discharge Current (I_{max}), Per Mode: 20 kA 8/20 μs
 Rated Nominal Discharge Current (I_n): 20 kA 8/20 us
 Frequency: 0 – 3 GHz
 Capacitance: 1.5 pF
 Insulation Resistance: 10 GΩ
 Impulse Life: 400 @ 500 A 10/1000 μs
 Enclosure Material: Metal
 Enclosure Rating: IP 20; NEMA®-1
 Temperature: -40 to 90 °C
 Certification: UL 497E

Features

- Simple plug-in installation
- Supplied with mounting bracket and flying lead ground
- Low insertion and return loss
- Wide operating frequency spectrum
- Low spark over voltage, better clamping
- Field-serviceable with replaceable GDT arrestor



Part Number	Connection Type	Spark-Over Voltage @ 100 V/μs	Spark-Over Voltage @ 100 V/s	Depth D	Height H	Width W	Unit Weight
CSP1NB90	N-Type, Female/Female	450 V	72 – 108 V	25.4 mm	25 mm	25 mm	133.4 g
CSP1NMF90	N-Type, Male/Female	450 V	72 – 108 V	25.4 mm	25 mm	25 mm	133.4 g
CSP1BNC90	BNC, Male/Female	450 V	72 – 108 V	25.4 mm	25 mm	25 mm	133.4 g
CSP1BNC600	BNC, Male/Female	1,100 V	480 – 720 V	25.4 mm	25 mm	25 mm	133.4 g
CSP1SMA90	SMA, Male/Female	450 V	72 – 108 V	25.4 mm	25 mm	25 mm	133.4 g
CSP1NB600	N-Type, Female/Female	1,100 V	480 – 720 V	25.4 mm	25 mm	25 mm	133.4 g
CSP1F90	F-Type, Male/Female	450 V	72 – 108 V	25.4 mm	25 mm	25 mm	133.4 g
CSP1F600	F-Type, Male/Female	1,100 V	480 – 720 V	25.4 mm	25 mm	25 mm	133.4 g
CSP1NBM90	N-Bulkhead, Male/Female	450 V	72 – 108 V	25.4 mm	25 mm	25 mm	133.4 g
CSP1NBM600	N-Bulkhead, Male/Female	1,100 V	480 – 720 V	25.4 mm	25 mm	25 mm	133.4 g
CSP1NMF600	N-Type, Male/Female	1,100 V	480 – 720 V	25.4 mm	25 mm	25 mm	133.4 g
CSP1SMA600	SMA, Male/Female	1,100 V	480 – 720 V	25.4 mm	25 mm	25 mm	133.4 g

Closed Circuit Television Protector

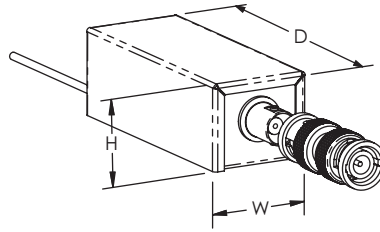

Features

- Robust high energy protection
- Compact package for limited space requirements
- Isolated ground prevents introduction of unwanted noise

Specification	CCTV12
Nominal System Voltage (Un)	+/- 12 VDC
Max Continuous Operating Voltage (Uc)	+/- 14 VDC
Voltage Protection Level (Up)	60 V @ 5 kA
Nominal Discharge Current (In)	10 kA 8/20 μ s
Frequency	100 MHz Max
Transmission Rate	16 Mb/s
Impedance	50 – 75 Ω
Connection Type	BNC, Female
Mounting	In-line insertion
Temperature	-25 to 70 °C
Enclosure Material	Metal
Enclosure Rating	IP 20 NEMA®-1
Depth (D)	27.9 mm
Height (H)	90 mm
Width (W)	22.1 mm
Unit Weight	60 g
Standard Packaging Quantity	1 pc
UPC	78285647021
EAN-13	8711893014204

Community Antenna Protector, High Frequency

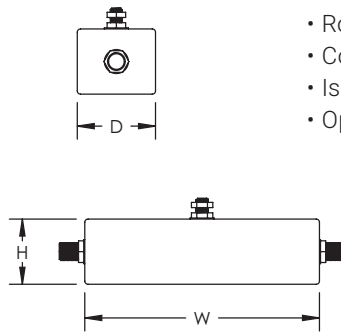

Features

- Robust high energy protection for cable television systems
- Compact package for limited space requirements
- Isolated ground prevents introduction of unwanted noise
- Optional mounting plate included

Part Number	CATVHF1
Clamping Voltage	180 VDC
Nominal Discharge Current (In)	5 kA 8/20 μ s
Frequency	0 – 1,000 MHz
Impedance	50 – 75 Ω
Insertion Loss	1 Db Max @ 500 MHz 2 Db Max @ 750 MHz
Connection Type	F-Type, Female
Temperature	-40 to 185 °F
Depth (D)	1 1/2"
Height (H)	1 1/4"
Width (W)	4 1/2"
Unit Weight	0.063 lb
Standard Packaging Quantity	1 pc
UPC	78285690879

LAN Surge Protector

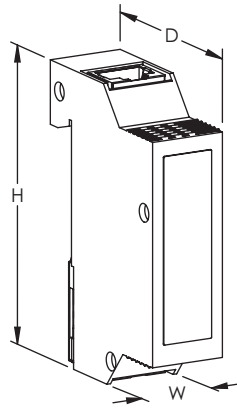
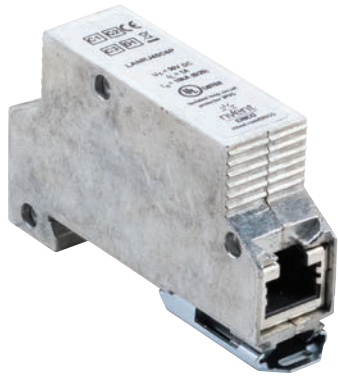

Features

- Rugged, metallic enclosure provides both environmental and electrical shielding
- Up to CAT6 and POE (Power Over Ethernet) protection in one product
- Simple, bi-directional installation

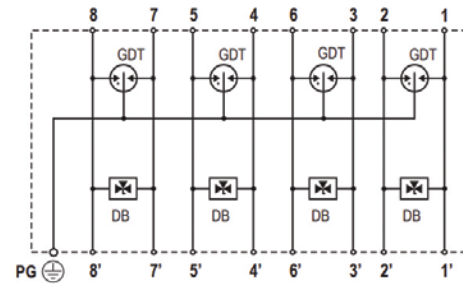

Specification	LANRJ45C6P
Nominal System Voltage (Un)	48 VDC
Max Continuous Operating Voltage (Uc)	50 VDC
Voltage Protection Rating (VPR), L-L	150 V
Voltage Protection Rating (VPR), L-PE	550 V
Nominal Discharge Current (In), L-L	150 A 8/20 μ s
Max Discharge Current (Imax), L-PE	10 kA 8/20 μ s
Impulse Current (Iimp)	1 kA 10/350 μ s
Rated Load Current (IL)	1 A
Frequency	250 MHz Max
Baud Rates	10, 100, 1000, 10000 Mbps
Temperature	-40 to 80 °C
Connection Type	RJ45
Enclosure Material	Metal
Enclosure Rating	IP 20
Depth (D)	45.5 mm
Height (H)	75 mm
Width (W)	19 mm
Complies With	IEC® 61643-21 UL 497B
Standard Packaging Quantity	1 pc
UPC	78285693008
EAN-13	0782856930082

Data Equipment Protector

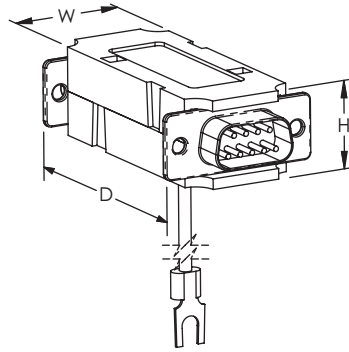

Features

- Models to cover RS-232, RS-423, RS-422 and RS-485 protocols
- Designed to provide both line to signal-ground and signal-ground to protective-earth protection
- Plug-in protection is simple to install

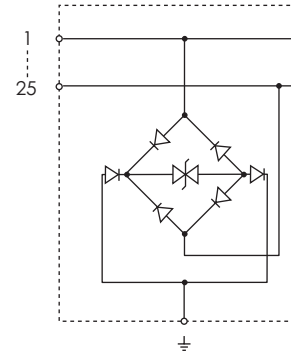

Part Number	DEPRS2322525D	DEPRS23299D	DEPRS42299D
Nominal Discharge Current (In)	300 A 8/20 μ s		400 A 8/20 μ s
Max Continuous Operating Voltage (Uc)	15 VDC		6 VDC
Capacitance	30 pF Max		
Protection Modes	All pins to ground		
Connection Type	DB25, Male/Female	DB9, Male/Female	
Depth (D)	2.4"		
Height (H)	0.66"		
Width (W)	2.11"	1.20"	
Unit Weight	0.17 lb	0.12 lb	

Universal Transient Barrier, Single Pair

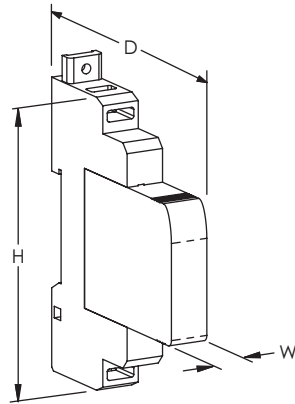

Features

- Compact design universal transient barrier provides protection of low-voltage circuits and transducers
- Separate plug and base design allows hot swappable module replacement
- Multi-stage protection and fine over-voltage protection helps ensure lowest residual surge voltages reach sensitive equipment
- Common-mode and differential-mode protection protects against both possible surge conditions
- Surge rating to 20 kA 8/20 μ s is ideal for exposed wiring
- Allows for protection of 25 analog signals or 50 digital signals per linear foot (0,3 m) of DIN rail space

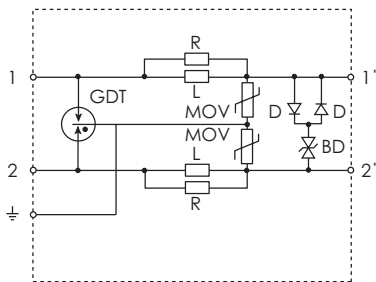

Specification	UTB5SP	UTB15SP	UTB30SP	UTB60SP	UTB110SP
Nominal System Voltage (Un)	0 - 3 VAC 0 - 5 VDC	3 - 10 VAC 5 - 15 VDC	10 - 21 VAC 15 - 30 VDC	21 - 42 VAC 30 - 60 VDC	100 - 120 VAC 60 - 154 VDC
Max Continuous Operating Voltage (Uc)	5 VAC 7 VDC	12 VAC 18 VDC	23 VAC 33 VDC	45 VAC 64 VDC	150 VAC 170 VDC
Frequency	0.5 MHz	1.0 MHz	2.0 MHz	3.0 MHz	3.0 MHz
Rated Load Current (IL)	2A				
Loop Resistance	1 Ω				
Max Discharge Current (Imax), L+L-PE	20 kA 8/20 μ s				
Protection Modes	Common, Differential				
Technology	Gas Discharge Tube (GDT), Metal Oxide Varistor (MOV), Silicon Avalanche Diode (SAD)				
Connection, Stranded	1.0 mm ² - 4.0 mm ² ; #18 - #12				
Mounting	35 mm top hat DIN rail				
Temperature	-20 to 65 °C				
Enclosure Material	UL [®] 94V-0 Thermoplastic				
Enclosure Rating	IP 20, NEMA [®] -1				
Depth (D)	72 mm				
Height (H)	90 mm				
Width (W)	12 mm				
Unit Weight	68 g				
Certification Details	UL [®] 497B				
Complies With	ANSI [®] /IEEE [®] C62.41.2-2002 Cat A, Cat B, Cat C				
Voltage Protection Level (Up), L-L	10 V @ 3 kA	25 V @ 3 kA	44 V @ 3 kA	85 V @ 3 kA	220 V @ 3 kA
Replacement Module	UTB5SPM	UTB15SPM	UTB30SPM	UTB60SPM	UTB110SPM
Certifications	CE NOM UR	CE UR	CE NOM UR	CE UR	CE NOM UR

Universal Transient Barrier, Dual Pair

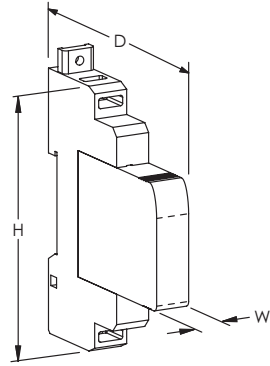

Features

- Compact design universal transient barrier provides protection of low-voltage circuits and transducers
- Separate plug and base design allows hot swappable module replacement
- Multi-stage protection and fine over-voltage protection helps ensure lowest residual surge voltages reach sensitive equipment
- Common-mode and differential-mode protection protects against both possible surge conditions
- Surge rating to 20 kA 8/20 μ s is ideal for exposed wiring
- Allows for protection of 25 analog signals or 50 digital signals per linear foot (0,3 m) of DIN rail space

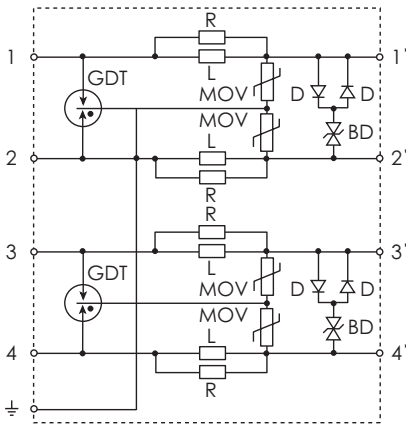

Part Number	UTB5DP	UTB15DP	UTB30DP	UTB60DP	UTB110DP
Nominal System Voltage (Un)	0 - 3 VAC 0 - 5 VDC	3 - 10 VAC 5 - 15 VDC	10 - 21 VAC 15 - 30 VDC	21 - 42 VAC 30 - 60 VDC	100 - 120 VAC 60 - 154 VDC
Max Continuous Operating Voltage (Uc)	5 VAC 7 VDC	12 VAC 18 VDC	23 VAC 33 VDC	45 VAC 64 VDC	150 VAC 170 VDC
Rated Load Current (IL)	800 mA				
Frequency	0.5 MHz	1.0 MHz	2.0 MHz	3.0 MHz	
Loop Resistance	0.6 Ω				
Max Discharge Current (Imax), L+L-PE	20 kA 8/20 μ s				
Protection Modes	Common Differential				
Technology	Gas Discharge Tube (GDT); Metal Oxide Varistor (MOV); Silicon Avalanche Diode (SAD)				
Voltage Protection Level (Up), L-L	10 V @ 3 kA	25 V @ 3 kA	44 V @ 3 kA	85 V @ 3 kA	220 V @ 3 kA
Connection, Stranded	#18 - #12				
Mounting	35 mm top hat DIN rail				
Temperature	-4 to 149 °F				
Enclosure Material	UL® 94V-0 Thermoplastic				
Enclosure Rating	IP 20 NEMA®-1				
Depth (D)	3.35"				
Height (H)	3.54"				
Width (W)	0.47"				
Unit Weight	0.2 lb				
Certification Details	UL® 497B				
Complies With	ANSI®/IEEE® C62.41.2-2002 Cat A, Cat B, Cat C				
Replacement Module	UTB5DPM	UTB15DPM	UTB30DPM	UTB60DPM	UTB110DPM
Certifications	CE, NOM, UR	CE, UR	CE, NOM, UR	CE, UR	CE, NOM, UR

Universal Transient Barrier, Single Pair Isolated Ground

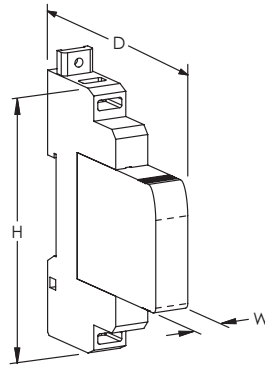

Features

- Compact design universal transient barrier provides protection of low-voltage circuits and transducers
- Separate plug and base design allows hot swappable module replacement
- Multi-stage protection and fine over-voltage protection helps ensure lowest residual surge voltages reach sensitive equipment
- Common-mode and differential-mode protection protects against both possible surge conditions
- Surge rating to 20 kA 8/20 μ s is ideal for exposed wiring
- Allows for protection of 25 analog signals or 50 digital signals per linear foot (0,3 m) of DIN rail space

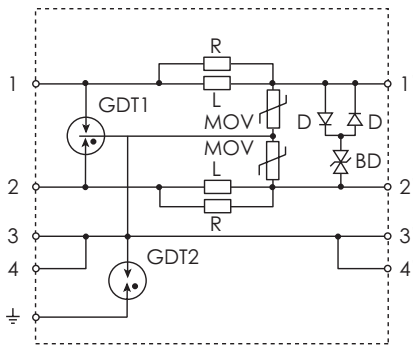

Part Number	UTB5SPG	UTB15SPG	UTB30SPG	UTB60SPG	UTB110SPG
Nominal System Voltage (Un)	0 - 3 VAC 0 - 5 VDC	3 - 10 VAC 5 - 15 VDC	10 - 21 VAC 15 - 30 VDC	21 - 42 VAC 30 - 60 VDC	100 - 120 VAC 60 - 154 VDC
Max Continuous Operating Voltage (Uc)	5 VAC 7 VDC	12 VAC 18 VDC	23 VAC 33 VDC	45 VAC 64 VDC	150 VAC 170 VDC
Rated Load Current (IL)	2 A				
Frequency	0.5 MHz	1.0 MHz	2.0 MHz	3.0 MHz	
Loop Resistance	1 Ω				
Max Discharge Current (Imax), L+L-PE	20 kA 8/20 μ s				
Protection Modes	Common Differential				
Technology	Gas Discharge Tube (GDT) Metal Oxide Varistor (MOV) Silicon Avalanche Diode (SAD)				
Voltage Protection Level (Up), L-L	10 V @ 3 kA	25 V @ 3 kA	44 V @ 3 kA	85 V @ 3 kA	220 V @ 3 kA
Connection, Stranded	#18 - #12				
Mounting	35 mm top hat DIN rail				
Temperature	-4 to 149 °F				
Enclosure Material	UL® 94V-0 Thermoplastic				
Enclosure Rating	IP 20 NEMA®-1				
Depth (D)	2.83"				
Height (H)	3.54"				
Width (W)	0.47"				
Unit Weight	0.15 lb				
Certification Details	UL® 497B				
Complies With	ANSI®/IEEE® C62.41.2-2002 Cat A, Cat B, Cat C				
Replacement Module	UTB5SPGM	UTB15SPGM	UTB30SPGM	UTB60SPGM	UTB110SPGM

Universal Transient Barrier, Modem/Telephone

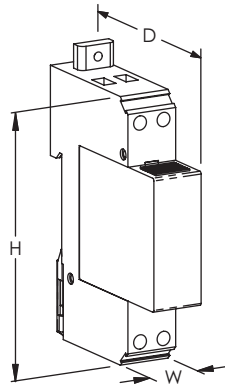

Features

- General purpose barrier provides protection of low-voltage circuits and transducers
- Separate plug and base design allows hot swappable module replacement
- Multi-stage protection and fine over-voltage protection helps ensure lowest residual surge voltages reach sensitive equipment

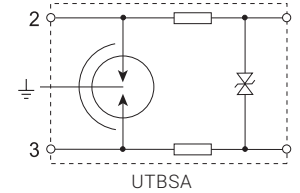
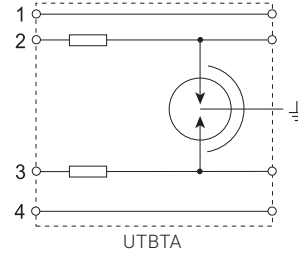

Part Number	UTBSA	UTBTA
Max Continuous Operating Voltage (Uc)	5 VAC 7 VDC	280 V
Frequency	15 MHz	
Voltage Protection Level (Up), L-L	340 V @ 3 kA	480 V @ 3 kA
Rated Load Current (IL)	160 mA	
Loop Resistance	1 Ω	
Max Discharge Current (Imax)	20 kA 8/20 μs L+L-PE	0.5 kA 8/20 μs Per Mode
Protection Modes	Common, Differential	
Technology	Gas Discharge Tube (GDT), PTC	
Connection, Stranded	#18 - #12	#18 - #12
Mounting	35 mm top hat DIN rail	
Temperature	-4 to 149 °F	
Enclosure Material	UL® 94V-0 Thermoplastic	
Enclosure Rating	IP 20, NEMA®-1	
Depth (D)	2.68"	
Height (H)	3.54"	
Width (W)	0.7"	
Unit Weight	0.22 lb	
Certification Details	UL® 497B	UL® 497A
Complies With	ANSI®/IEEE® C62.41.2-2002 Cat A, Cat B, Cat C	
Replacement Module	UTBSM	UTBTM
Certifications	CE; NOM	CE

nVent ERICO Protection Device, F-Series

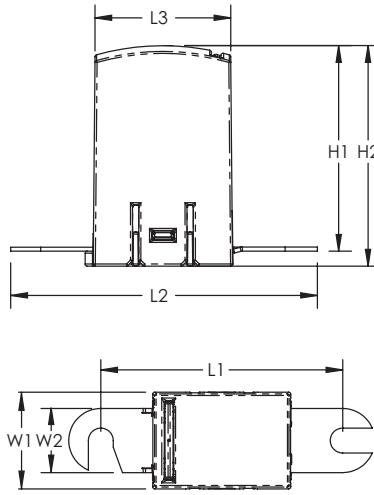
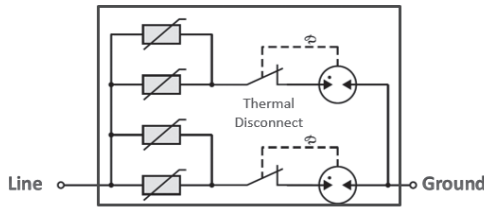

Features

- Protects sensitive electronic equipment
- Reduced operating and maintenance costs
- Visual indicator
- Open-circuit end-of-life mode
- Proven hybrid technology comprised of gap-type and varistor-type components
- Epoxy coating ensures stability under adverse environmental conditions
- Two operating voltages
- 50kA 8/20 μ s maximum surge rating
- AREMA[®] binding post terminals
- Exceeds AREMA[®] recommendations for arrester applications
- 5-year limited warranty

nVent ERICO is a world leader in grounding, bonding, surge and lightning protection in the railway industry, offering an extensive line of wayside surge protection. The EPD F-Series provides transient protection from surges induced or conducted onto low-voltage signal circuits for trackside signaling equipment. This series of surge-protection devices is ideal for microprocessor-based train-control and indication circuits, train inspection systems, communications systems, highway crossing controls and other operationally sensitive systems. Wayside rail-industry electronic-equipment environments are prone to dangerous and damaging voltage surges and transients. The EPD F-Series proven hybrid technology diverts surge currents to minimize the likelihood of

system damage, reducing system down time and repair costs. nVent ERICO's design safeguards the devices against shorts, provides status indication at a glance and ensures uninterrupted signal operation when the device reaches end of life. Visual inspection is a key design feature. The device cover is color-coded and marked with the operating voltage and part number, which allows easy identification for proper application. nVent ERICO is committed to providing engineered high quality and technologically advanced solutions to the unique applications of the railway industry and has served the worldwide market for over 100 years. Railway systems around the world depend on nVent ERICO solutions to keep their systems running safely and efficiently.

Part Number	EPD2050F	EPD2170F
Nominal System Voltage (Un)	50 VDC; 35 VAC	170 VDC; 120 VAC
Max Continuous Operating Voltage (Uc)	90 VDC; 65 VAC	220 VDC; 150 VAC
Voltage Protection Level (Up)	250 V @ 3 kA	500 V @ 3 kA
Nominal Discharge Current (In)	30 kA 8/20 μ s	20 kA 8/20 μ s
Max Discharge Current (Imax)	50 kA 8/20 μ s	
Leakage Current @ Un	1 nA Max	
Frequency	5 MHz Max	
Protection Modes	Single, L-L or L-PE	
Technology	Metal Oxide Varistor (MOV); Gas Discharge Tube (GDT)	
Connection Type	AREMA [®] Stud-Type Terminals – 2 Post Terminal Block	
Status Indication	Mechanical flag	
Enclosure Material	UL [®] 94V-0 Thermoplastic	
Enclosure Rating	IP 20; NEMA [®] -1	
Humidity	0 – 95 % RH	
Temperature	-40 to 176 °F	
Length 1 (L1)	2 3/8"	
Length 2 (L2)	3"	
Length 3 (L3)	1.3"	
Width 1 (W1)	0.95"	
Width 2 (W2)	0.63"	
Height 1 (H1)	2"	
Height 2 (H2)	2.2"	
Unit Weight	0.15 lb	
Complies With	ANSI [®] /IEEE [®] C62.41.2-2002 Cat A, Cat B, Cat C; AREMA [®] requirements	
Color	Transparent Blue	Transparent Yellow

nVent ERICO Protection Device, EPD100P Series

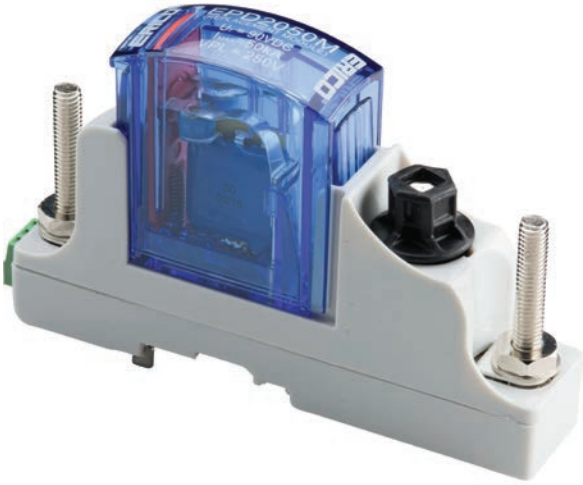

nVent ERICO is a world leader in grounding, bonding, surge and lightning protection in the railway industry offering an extensive line of wayside surge protection. The EPD100P Series provides a DIN rail mounting terminal block with a plug-in type surge protection module. The plug-in surge module provides transient protection from surges induced or conducted onto low-voltage signal circuits for trackside signaling equipment. The EPD100P DIN rail mounting base is designed specifically to suit the demands and common practices of wayside rail signaling applications. Defining features such as the binding post terminations and integrated disconnect ensure the design conforms to AREMA standards and established maintenance practices. A key feature is the DIN rail coupler which serves to mount the device while simultaneously creating a low-impedance path to ground. Wayside rail-industry electronic-equipment environments are prone to dangerous and damaging voltage surges and transients. In order to protection against surges and transients, the EPD100P Series utilizes the same proven hybrid design employed in the EPD F-Series. This hybrid surge protection technology diverts surge currents to minimize the likelihood of system damage, reduce system down time, and minimize repair costs. nVent ERICO's surge module design safeguards the devices against shorts, provides status indication at a glance and ensures uninterrupted signal operation when the device reaches end of life.



nVent ERICO Protection Device Kit



nVent ERICO Protection Device Replacement Module



nVent ERICO Protection Device Replacement Base



DIN Rail

nVent ERICO Protection Device Kit

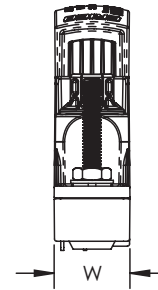
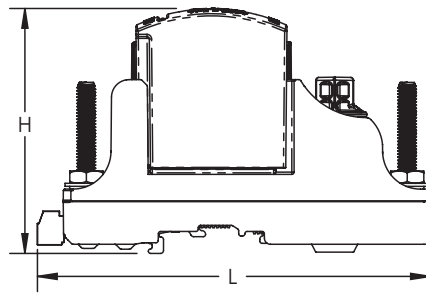

Features

- Fusion of terminal block and surge protection technology
- Integrated disconnect
- Reduces installation time
- Open-circuit end-of-life mode
- Proven hybrid technology comprised of gap-type and varistor-type components
- Includes AREMA® hardware
- Two operating voltages
- 5-year limited warranty
- RoHS compliant

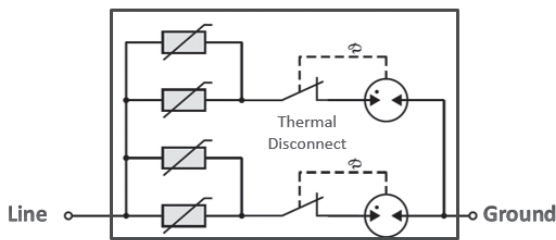

Part Number	EPD101P	EPD102P
Nominal System Voltage (Un)	50 VDC; 35 VAC	170 VDC; 120 VAC
Max Continuous Operating Voltage (Uc)	90 VDC; 65 VAC	220 VDC, 50 VAC
Voltage Protection Level (Up)	250 V @ 3 kA	500 V @ 3 kA
Nominal Discharge Current (In)	30 kA 8/20 μs	20 kA 8/20 μs
Max Current Rating	30 A	
Max Discharge Current (Imax)	50 kA 8/20 μs	
Leakage Current @ Un	1 nA Max	
Frequency	5 MHz Max	
Protection Modes	Single	
Technology	Metal Oxide Varistor (MOV); Gas Discharge Tube (GDT)	
Connection Type	AREMA® 14-24 Binding Posts	
Mounting	35 mm top hat tinned copper DIN rail	
Status Indication	Mechanical flag; Remote Contacts	
Enclosure Material	UL® 94V-0 Thermoplastic	
Humidity	95 % RH Max	
Working Temperature	-40 to 185 °F	
Height (H)	3.3"	
Length (L)	5.2"	
Width (W)	1"	
Wrench Size	1/2"	
Color	Blue	Yellow
Complies With	AREMA® C&S Manual Parts 11.5.1, 11.3.2, 14.1.2	
Designed to Meet	ANSI®/IEEE® C62.41.2-2002 Cat A, Cat B, Cat C	

nVent ERICO Protection Device Replacement Module

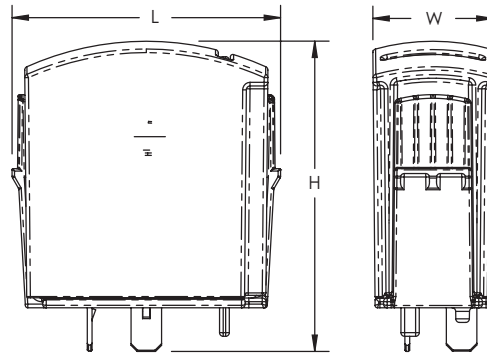

Features

- Proven hybrid technology comprised of gap-type and varistor-type components
- Two operating voltages
- Open-circuit end-of-life mode
- Reduces installation time
- 5-year limited warranty
- RoHS compliant

Part Number	EPD2050M	EPD2170M
Nominal System Voltage (Un)	50 VDC; 35 VAC	170 VDC; 120 VAC
Max Continuous Operating Voltage (Uc)	90 VDC; 65 VAC	220 VDC; 50 VAC
Voltage Protection Level (Up)	250 V @ 3 kA	500 V @ 3 kA
Nominal Discharge Current (In)	30 kA 8/20 μ s	20 kA 8/20 μ s
Max Current Rating	30 A	
Max Discharge Current (Imax)	50 kA 8/20 μ s	
Leakage Current @ Un	1 nA Max	
Frequency	5 MHz Max	
Protection Modes	Single	
Technology	Metal Oxide Varistor (MOV); Gas Discharge Tube (GDT)	
Status Indication	Mechanical flag	
Enclosure Material	UL [®] 94V-0 Thermoplastic	
Humidity	95 % RH Max	
Working Temperature	-40 to 185 °F	
Height (H)	2.55"	
Length (L)	2.2"	
Width (W)	1"	
Color	Blue	Yellow
Complies With	AREMA [®] C&S Manual Parts 11.5.1, 11.3.2, 14.1.2	
Designed to Meet	ANSI [®] /IEEE [®] C62.41.2-2002 Cat A, Cat B, Cat C	

nVent ERICO Protection Device Replacement Base

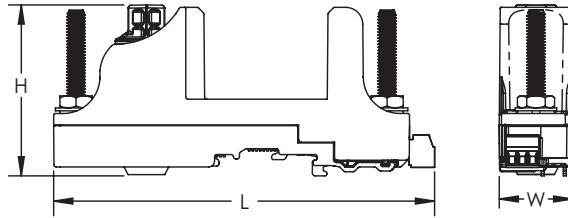

Features

- Integrated disconnect
- Includes AREMA® hardware
- Reduces installation time
- 5-year limited warranty
- RoHS compliant

Part Number	EPD100P
Connection Type	AREMA® 14-24 Binding Posts
Mounting	35 mm top hat tinned copper DIN rail
Status Indication	Remote Contacts
Enclosure Material	UL® 94V-0 Thermoplastic
Humidity	95 % RH Max
Working Temperature	-40 to 185 °F
Height (H)	2.3"
Length (L)	5.2"
Width (W)	1"
Wrench Size	1/2"
Complies With	AREMA® C&S Manual Parts 11.5.1, 11.3.2, 14.1.2
Designed to Meet	ANSI®/IEEE® C62.41.2-2002 Cat A, Cat B, Cat C

DIN Rail

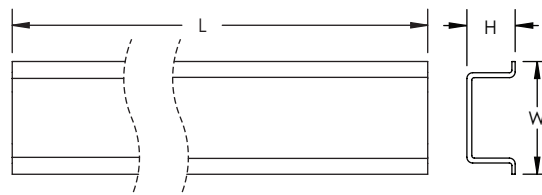

Features

- Conforms to EN 60715 and 50022 and DIN 46277
- RoHS compliant

Material: Copper Alloy
Finish: Tinned

Part Number	Width W	Height H	Length L
CDR7	7.5 mm	35 mm	2 m
CDR15	15.0 mm	35 mm	2 m

Electronic Track Signal Protector

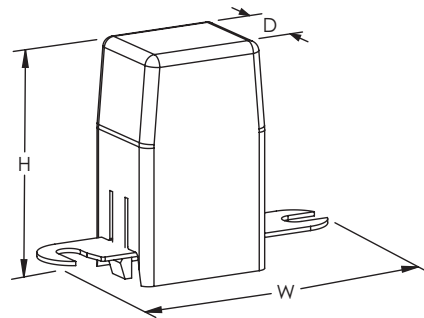

Features

- Includes hybrid technology comprised of gap-type voltage switching and varistor-type voltage clamping components
- Designed with a fail-safe, isolated from ground failure modes as required for critical signal circuits
- Protects sensitive electronic equipment in exposed locations
- Epoxy coating helps ensure stability of operation under adverse conditions and in locations of high humidity
- Exceeds the AREMA® specifications for both arrester and equalizer applications
- Provides a 50 kA 8/20 maximum surge rating for protection that is suitable for exposed trackside equipment

The nVent ERICO Electronic Track Signal Protector series provides transient protection from surges induced or conducted onto low-voltage signal circuits for trackside signaling equipment. The series of surge-protection devices is ideal for protecting DC-responsive track relays, train-detection systems, microprocessor-based train-control and indication circuits, train inspection systems, communications systems, highway crossing

controls and other operationally sensitive systems. nVent ERICO Electronic Track Signal Protector devices help ensure that surges do not pose a safety threat in the event of component failure. Indicators on the device help safeguard the device against shorts and provide status indication at a glance. The device cover is marked with the operating voltage and part number, which allows easy identification as to proper application.

Part Number	ETSP33050	ETSP330170
Nominal System Voltage (Un)	50 VDC; 35 VAC	170 VDC; 120 VAC
Max Continuous Operating Voltage (Uc)	90 VDC; 65 VAC	220 VDC; 150 VAC
Voltage Protection Level (Up)	300 V @ 3 kA	550 V @ 3 kA
Nominal Discharge Current (In)	30 kA 8/20 μ s L+L-PE	20 kA 8/20 μ s L+L-PE
Max Discharge Current (Imax)	50 kA 8/20 μ s L+L-PE	
Leakage Current @ Un	1 nA Max	
Frequency	5 MHz Max	
Protection Modes	Two Mode, L1-PE and L2-PE	
Technology	Metal Oxide Varistor (MOV); Gas Discharge Tube (GDT)	
Connection Type	AREMA® Stud-Type Terminals – 2 Post Terminal Block	
Status Indication	Dual spring thermal disconnect	
Enclosure Material	UL® 94V-0 Thermoplastic	
Enclosure Rating	IP 20; NEMA®-1	
Humidity	0 – 90 % RH	
Temperature	-40 to 176 °F	
Depth (D)	0.98"	
Height (H)	2.96"	
Width (W)	2.16"	
Unit Weight	0.24 lb	
Complies With	ANSI®/IEEE® C62.41.2-2002 Cat A, Cat B, Cat C; IEC® 61643-1 Class II; AREMA® requirements	
Color	Transparent	Yellow

Frequency @ 3 dB / 120 Ω .

RTBN Rail Transient Barrier

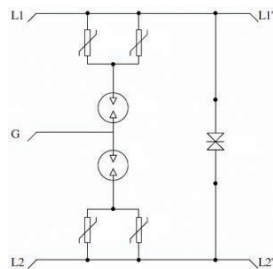
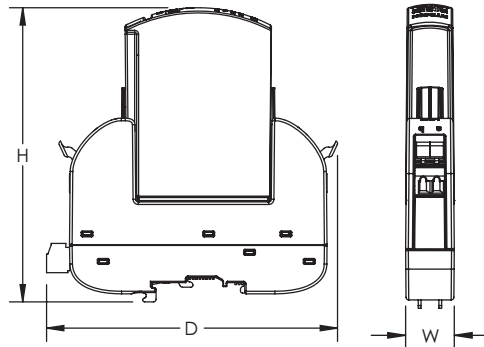

RTB12N & RTB30N

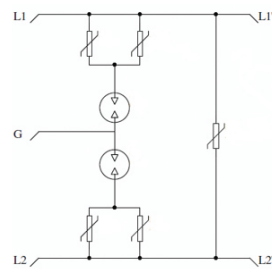

RTB50N & RTB130N

Features

- Surge module easily snaps into place
- Mechanical flag will protrude to indicate the module needs to be replaced
- Thermal disconnect releases the indicator when the device reaches end-of-life, disconnecting itself from the circuit to prevent it from becoming a short or shunt
- Surge module attaches to the base with a latching mechanism that easily locks the device into place, preventing the module from disconnecting during service
- Integration of GDT (gas discharge tube) technology and MOV (metal oxide varistors), a combination that delivers consistency and the capability to protect against fast spikes
- Screw-less cage clamp terminal allows for easy connection, solid or stranded wires are simply pushed in to lock into place, reducing installation time by as much as 75%
- DIN rail grounding connection eliminates the need for extra grounding wires

Part Number	RTB12N	RTB30N	RTB50N	RTB130N
Nominal System Voltage (Un)	12 VDC; 9 VAC	30 VDC; 21 VAC	50 VDC; 35 VAC	130 VDC; 110 VAC
Max Continuous Operating Voltage (Uc)	18 VDC; 12 VAC	33 VDC; 23 VAC	65 VDC; 50 VAC	170 VDC; 130 VAC
Max Discharge Current (Imax)	40 kA 8/20 μs			
Rated Load Current (IL)	15 A			
Voltage Protection Rating (VPR)	65 V @ 3 kA L-L 245 V @ 3 kA L+L-PE	105 V @ 3 kA L-L 245 V @ 3 kA L+L-PE	230 V @ 3 kA L-L 245 V @ 3 kA L+L-PE	530 V @ 3 kA L-L 495 V @ 3 kA L+L-PE
Loop Resistance	900 μΩ			
Mounting	35 mm top hat DIN rail; G type DIN rail			
Protection Modes	L-L; L+L-PE			
Status Indication	Mechanical flag; Remote Contacts			
Connection, Solid	#18 – #12			
Connection, Stranded	#18 – #12			
Enclosure Material	UL® 94V-0 Thermoplastic			
Enclosure Rating	IP 20			
Temperature	-40 to 185 °F			
Depth (D)	4.22"			
Height (H)	4.33"			
Width (W)	0.71"			
Unit Weight	0.22 lb			
Complies With	AREMA® C&S Manual Parts 11.5.1, 11.3.2, 14.1.2; ANSI®/IEEE® C62.41.2-2002 Cat A, Cat B, Cat C			
Color	Red	Black	Purple	Yellow
Replacement Module	RTBN12M	RTBN30M	RTBN50M	RTBN130M

Remote Transmitter Protector

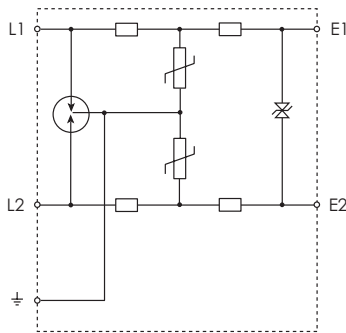
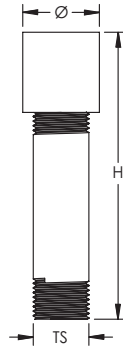

Features

- Three stage protection and fine over-voltage protection helps ensure lowest residual surge voltage reaches sensitive equipment
- Flexible installation allows enclosure to be installed "dead ended", "T" configured or in-line
- Optimized for protection of 2-wire industrial 4-20mA loops and suitable for exposed locations
- Supports line currents up to 145mA and protects 24VDC powered equipment



Part Number	RTP3034
Nominal System Voltage (Un)	21 VAC 30 VDC
Max Continuous Operating Voltage (Uc)	23 VAC 33 VDC
Voltage Protection Level (Up), L-L	44 V @ 3 kA
Max Discharge Current (Imax), L+L-PE	20 kA 8/20 μ s
Rated Load Current (IL)	145 mA
Loop Resistance	14 Ω
Protection Modes	Common Differential
Technology	Gas Discharge Tube (GDT); Metal Oxide Varistor (MOV); Silicon Avalanche Diode (SAD)
Enclosure Material	Stainless Steel
Enclosure Rating	IP 55
Temperature	-40 to 149 °F
Thread Size (TS)	3/4 NPT
Diameter (Ø)	1.38"
Height (H)	5"
Designed to Meet	ANSI®/IEEE® C62.41.2-2002 Cat A, Cat B, Cat C
Certifications	CE; Qualifoudre
Standard Packaging Quantity	1 pc
UPC	78285652666
EAN-13	8711893027549

Load Cell Protector

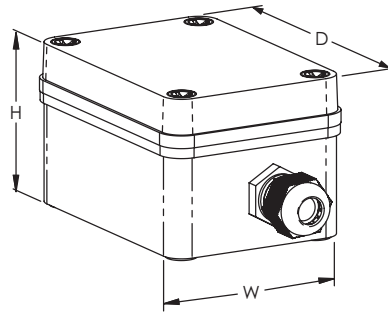

Features

- Six wires and shield protection works with four or six wire systems
- Suitable for compression or tension cells
- Low series impedance, loadcells do not need recalibration
- NEMA®-12 (IP-55) rated, suitable for outdoor use
- Helps protect against excitation over-voltage and prevent loadcell damage

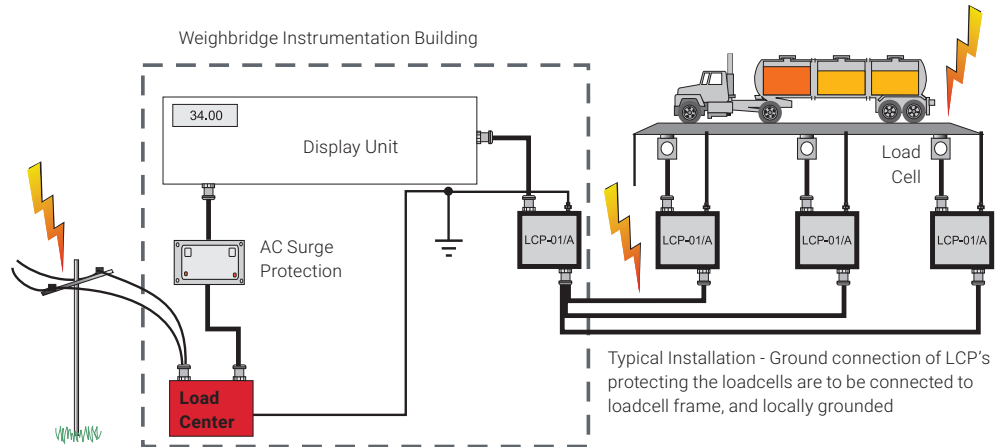
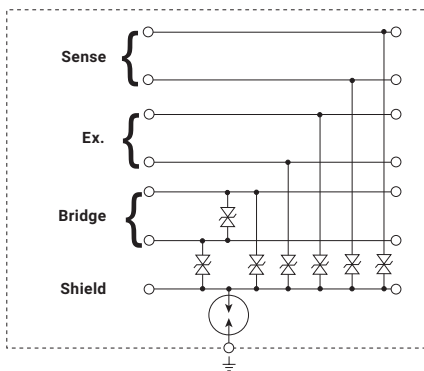

Part Number	LCP01A
Max Discharge Current (Imax), Shield to Ground	10 kA 8/20 μs
Max Discharge Current (Imax), Signal to Shield	0.3 kA 8/20 μs
Voltage Protection Level (Up), Shield to Ground	90 V
Voltage Protection Level (Up), Signal to Shield	30 V
Voltage Protection Level (Up), Signal to Signal	15 V
Loop Resistance	0.3 Ω
Technology	Silicon Avalanche Diode (SAD)
Material	Acrylonitrile Butadiene Styrene
Enclosure Rating	NEMA® 12 (IP55)
Depth (D)	4.33"
Height (H)	2.2"
Width (W)	2.95"
Unit Weight	0.55 lb
Temperature	-40 to 176 °F
Certifications	Qualifoudre
Standard Packaging Quantity	1 pc
UPC	78285644014
EAN-13	9321098000804

NEMA is a registered service mark of National Electrical Manufacturers Association.

Surge Counter, Digital Display

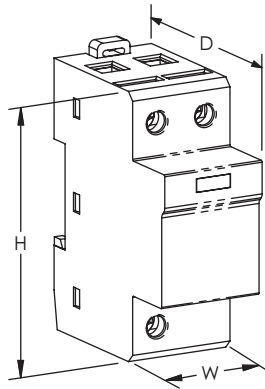

Features

- Records time and date of transient surge events
- Resettable counter
- Snap on, hall effect transducer

Part Number	DSCL2	
Trip Threshold	100 A 8/20 μ s	
Status Indication	LED	
Connection, Stranded	2/0 Max	
Lead Length	20"	
Enclosure Material	UL [®] 94V-0 Thermoplastic	
Enclosure Rating	IP 20 NEMA [®] -1	
Mounting	35 mm top hat DIN rail	
Temperature	-4 to 158 °F	
Module Width	2 M	
Depth (D)	2.68"	
Height (H)	3.54"	
Width (W)	1.42"	
Unit Weight	0.42 lb	
Standard Packaging Quantity	1 pc	
UPC	78285680444	
EAN-13	8711893146950	

Potential Equalization Clamp

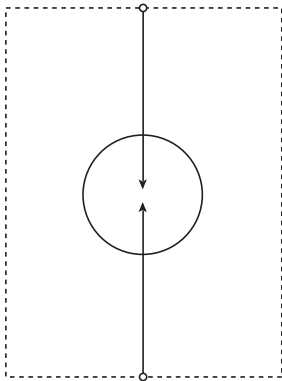
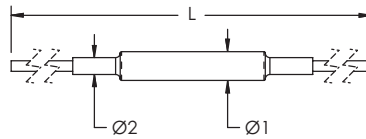

Features

- High peak current capability provides long service life
- Weatherproof enclosure is suitable for direct burial
- The PEC100 is ATEX approved and suitable for use in potentially explosive atmospheres



Part Number	PEC100
Spark-Over Voltage @ 100 V/s	350 V
Max Discharge Current (Imax)	100 kA 8/20 μ s
Technology	Gas Discharge Tube (GDT)
Insulation Resistance	1 G Ω Min
Capacitance	15 pF Max
Voltage Protection Level (Up)	800 V @ 1,000 V/ μ s
Impulse Current (Iimp)	25 kA 10/350 μ s
Lead Length	17"
Lead Size	#5
Enclosure Rating	IP 66; IP 67
Temperature	-22 to 158 °F
Diameter 1 (Ø1)	1.1"
Diameter 2 (Ø2)	0.64"
Length (L)	37 1/2"
Unit Weight	1.1 lb
Complies With	IEC® 61643-1 Class I, Class II IEC® 62561-3
Certifications	ATEX Baseefa13ATEX0113X CE; IECEx BAS 13.0065X; Qualifoudre
EAN-13	9321098000804
Standard Packaging Quantity	1 pc
UPC	78285656478
EAN-13	8711893027570

Spark-over voltage has a tolerance of +/- 20%.

IEC is a registered trademark of the International Electrotechnical Commission.

MOV/GDT/SAD Tester MGATESTER1

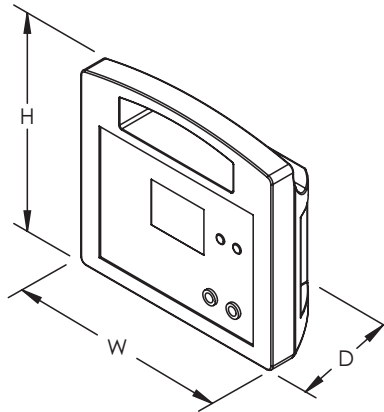

Features

- Measurement of metal oxide varistors, gas discharge tubes, and avalanche diodes
- Ability to display up to 50 measurements
- Adjustable test settings
- Rechargeable battery

nVent ERICO testers are designed for rapid testing of the integrity of surge protection device components. Because standard metal oxide varistors, gas arresters, and avalanche diodes do not provide the user with a visual indication of the integrity of the protection capacity, an external means of testing is required. It is impossible to predict when these failures will occur without some form of

testing. As MOVs approach the end of their life cycle, they exhibit a change in tolerance levels. nVent ERICO testing products are specifically designed to identify these situations and allow the operator to effect remedial replacement to the devices which are nearing the end of their life cycle. They can test both components, as well as replacement modules such as the TDS or DSD

Part Number	MGATESTER1
Test Voltage	1,500 VDC Max
GDT Voltage Ramp	100 V/s 1,000 V/s
MOV/SAD Test Current	0.1 mA 0.5 mA 1.0 mA
Enclosure Rating	IP 20
Temperature	14 – 122 °F
Depth (D)	3.23"
Height (H)	8.07"
Width (W)	8.66"
Unit Weight	2.09 lb
Standard Packaging Quantity	1 pc
UPC	78285691000

Glossary of Terminology

8/20 μ s CURRENT WAVESHAVE

A current impulse with a virtual front time of 8 μ s and a time to half-value of 20 μ s.

AGGREGATE SURGE RATING

The sum of the surge ratings of individual voltage limiting components, connected in parallel, in the device.

Note: This figure does not indicate the maximum discharge current (I_{max}) of the device. It does however provide an indication of the expected SPD life. Users should be aware that certain manufacturers may incorrectly claim the aggregate surge rating of MOV material used in their device as its I_{max} . Non-perfect current sharing between parallel MOVs, and the inability of series over-current or thermal disconnects to carry the full surge current, generally means that the maximum discharge current which the SPD can withstand is less than its aggregate surge rating.

ATTENUATION

The ability of an SPD to reduce electrical noise interference, measured in decibels. Attenuation varies with frequency, so it is usual to specify the attenuation of the SPD at a particular frequency; commonly 100kHz.

BACKUP OVERCURRENT PROTECTION

An external overcurrent protective device installed prior to the SPD. Such a device may be required if the overcurrent limiting device on the service is larger than that required by the SPD or connecting wiring.

Class I test

SPD tested with maximum impulse current (I_{imp}) and nominal discharge current (I_n).

Class II test

SPD tested with maximum discharge current (I_{max}) and nominal discharge current (I_n).

Class III test

SPD tested with combination wave.

DISTRIBUTION SYSTEM

Defines the electrical power distribution system. The distribution system is usually described by configuration of the phases, neutral and ground conductor configuration on the secondary side of the supply transformer. Refer to pages 10-12 for further information.

FOLLOW CURRENT (I_f)

The current supplied by the electrical power distribution system which flows through the SPD after a discharge current impulse. The follow current is significantly higher than the operating current, and is normally high for voltage switching type SPDs (e.g. spark gaps) since the arc voltage falls below the AC supply voltage after firing.

IMPULSE CURRENT (I_{imp})

Peak impulse current withstand with a 10/350 μ s current waveshape. This is often used for the classification of SPDs tested to Test Class I, but is not the only acceptable waveshape.

INSERTION LOSS

The insertion loss of an SPD is usually only stated for two port devices for use on low voltage data systems. It is a measure of the ratio of voltage at the output to the input at the device under test. The insertion loss is usually stated for a given frequency and measured in decibels.

LEAKAGE CURRENT

The current flowing to the ground conductor when the SPD is connected to the nominal supply voltage U_n .

LET-THROUGH VOLTAGE

Another term often used to describe the measured limiting voltage.

Note: This measurement may be carried out with, or without, the presence of the nominal AC power (U_n) being applied to the SPD. As such, the results may be different and the user should take cognizance of this in making any comparative assessments.

LOCATION CATEGORIES

Various standards attempt to define the electrical environment at which an SPD may be installed, into location categories or zones.

Note: The user should be aware that international consensus has not been reached on these classifications, nor on the size of expected surge activity, which may occur. Further, the user should note that the demarcation of these zones do not form literal boundaries, but are rather a gradual transition.

MAXIMUM CONTINUOUS OPERATING VOLTAGE (U_c)

The maximum r.m.s. or d.c. voltage which may be continuously applied to the SPD's mode of protection without degradation or inhibiting its correct operation.

Note: Specifications given in the catalog generally are phase (L-N) voltages.

MAXIMUM DISCHARGE CURRENT (I_{max})

The maximum single shot current, having an 8/20 μ s waveshape, which the SPD can safely divert.

MEASURED LIMITING VOLTAGE

The maximum voltage measured across the SPD's terminals during the application of an impulse of specified waveshape and amplitude.

MODES OF PROTECTION

SPDs may provide protection line-to-ground, line-to-neutral, neutral-to-ground or in combinations thereof. These paths are referred to as the modes of protection.

Note: The user is advised that not all modes require protection, and more is not necessarily better when selecting an SPD. As an example, the N-G mode is not required when the SPD is installed at the primary service entrance of a TN-C-S electrical distribution system, due to the Neutral-Ground bond at this point. The L-L mode is generally not provided for systems with neutral conductors since the L-N modes also protect the L-L modes. Similarly, the L-G mode can be protected via the L-N and N-G modes.

NOMINAL DISCHARGE CURRENT (I_n)

The peak value of the current flowing through the SPD during the application an 8/20 μ s waveshape.

Note: IEC 61643-1 requires SPDs tested to Test Class II, to withstand 15 impulses at I_n followed by 0.1, 0.25, 0.5, 0.75 and 1.0 times I_{max} .

NOMINAL (SYSTEM) VOLTAGE (U_n)

The L-N voltage by which an electrical power system is designated. Under normal system conditions, the voltage at the supply terminals may differ from the nominal voltage as determined by the tolerance of the supply system (normally +/- 10%).

Glossary of Terminology

ONE-PORT SPD

An SPD connected in shunt (parallel) with the circuit to be protected. A one port device may have separate input and output terminals, but without a specific series impedance between these terminals. This type of connection is also known as a Kelvin connection. Operating Current

The current drawn (per phase) by the SPD when energized at the nominal operating voltage U_n .

Note: For SPDs with integral series filtering, the total current drawn may be greater than the real rms current consumption (i.e. VA may be greater than Watts). This is due to the presence of the internal filtering capacitance.

OVER-CURRENT PROTECTION

An over-current device, such as a fuse or circuit-breaker, which could be part of the electrical distribution system located externally and up-stream of the SPD. May provide protection to the SPD, the connecting wiring and provide a means of externally isolating the SPD.

PROTECTIVE EARTH (PE)

The IEC® 60364 series characterizes low-voltage distribution systems by their grounding methods and the configuration of the neutral and protective conductors. The Protective Earth is commonly referred to as "ground", or "earth", in many regions.

RATED LOAD CURRENT (I_L)

Maximum continuous rated current that can be supplied to a load connected to the protected output of an SPD. Normally only stated for two port, series connected, SPDs.

RESIDUAL VOLTAGE

In IEC terminology this refers to the peak value of the voltage that appears between the terminals of an SPD due to the passage of discharge current I_n . NZS/AS 1768 refers to this as the let-through voltage, a measurement obtained when the stated test impulse is superimposed on top of the nominal system voltage U_n .

SECONDARY SURGE ARRESTER

A loosely used term given to SPDs intended for operation on medium voltage systems (>1kV). Within the USA, a secondary surge arrester defines an SPD Listed by Underwriters Laboratories Inc. for use on LV and MV systems at locations prior to the main overcurrent disconnect to the facility.

Note: Secondary Surge Arrester Listing is generally considered to have less demanding safety requirements than those for UL® 1449 Transient Voltage Surge Arrester Listing.

SHORT CIRCUIT CURRENT RATING (SCCR)

The short-circuit current rating of the SPD. Required by USA National Electric Code (NEC®) for TVSS devices.

SPD DISCONNECTOR

An IEC term used to describe a device (internal and/or external) for disconnecting an SPD from the electrical power system.

Note: This disconnecting device is not required to have isolating capability. It is to prevent a persistent fault on the system and is used to give an indication of the SPD failure. There may be more than one disconnect function, for example an over-current protection function and a thermal protection function. These functions may be integrated into one unit or performed in separate units.

SPARK-OVER VOLTAGE

The voltage at which a switching type SPD (generally of the spark gap type) will initiate conduction. This value is normally specified for a voltage increasing at 1kV/s.

STATUS INDICATOR

A device(s) that indicates the operational status of the SPD, or of a particular mode of its protection.

Note: Such indicators may be local with visual and/or audible alarms and/or may have remote signaling and/or output contact capability.

SUPPRESSED VOLTAGE RATING (SVR)

A special case of the measured limiting voltage specific to the UL 1449 Listing of an SPD.

Note: This test is performed using a small 500A 8/20µs current limited impulse, and the clamping voltage recorded at the ends of 6" connecting leads. The result obtained is rounded up to the nearest value given in a table.

SURGE PROTECTION DEVICE (SPD)

An IEC term used to describe a device intended to limit transient over-voltages and divert surge currents. It contains at least one non-linear component.

SURGE (REDUCTION) FILTER

A two-port series filtering type of SPD specifically designed to reduce the rate-of-rise of voltage (dv/dt) of the pre-clamped waveform. Such a device normally contains a filter with low-pass performance.

TRANSIENT VOLTAGE SURGE SUPPRESSOR (TVSS)

An SPD tested to meet the safety requirements of UL 1449 - Standard for Transient Voltage Surge Suppressors. UL 1449 defines the basic safety requirements for TVSS devices installed on electrical circuits up to 600V. The United States National Electric Code (NEC) only permits TVSS devices to be installed after (downstream of) the main over-current disconnect to a facility.

TWO-PORT SPD

An SPD with two sets of terminals, input and output (line and equipment), and with a specific impedance inserted between these terminals. These are often referred to as series (in-line) connected SPDs and generally contain wave-shaping filters in addition to simple shunt-only protection.

VOLTAGE PROTECTION LEVEL (U_p)

Similar to the measured limiting voltage, the voltage protection level characterizes the performance of an SPD in limiting the voltage across its terminals.

Note: The voltage protection level is the measured limiting voltage recorded under a specified current magnitude and waveshape, and rounded up to the next highest voltage selected from a list of preferred values found in IEC 61643-1 Standard for surge protective devices connected to low-voltage power distribution systems. For SPDs tested to Test Class I, U_p is generally stated using a 10/350 I_{imp} and for SPDs tested to Test Class II, using an 8/20µs I_{max} .

VOLTAGE PROTECTION RATING (VPR)

A rating selected from a list of preferred values as given in Table 63.1 of ANSI®/UL 1449 and assigned to each mode of protection. The value of the VPR is determined as the nearest highest value taken from Table 63.1 to the measured limiting voltage determined during the transient-voltage surge suppression test using the combination wave generator at a setting of 6 kV, 3 kA.

Our powerful portfolio of brands:

CADDY ERICO HOFFMAN RAYCHEM SCHROFF TRACER



[nVent.com/ERICO](https://www.nvent.com/ERICO)

©2019 nVent. All nVent marks and logos are owned or licensed by nVent Services GmbH or its affiliates. All other trademarks are the property of their respective owners. nVent reserves the right to change specifications without notice.

ERICO-CAT-E1330C-SurgeProtectionSolutions-USEN-1910