

nVent Hoffman Purge/Pressurization Manual for Models for PCFF1YZ PCFB1YZ

This manual covers Y/Z - Purge with Continuous Flow

CONTENTS:

- 1. Specification Sheet – CF Y/Z – Purge/Pressurization Unit**
- 2. Application Suitability**
- 3. Installation, Operation and Maintenance for CF Units**
 - Section 0. Description and Principle of Operation**
 - Section 1. Installation of the Unit**
 - Section 2. Operation of the Unit**
 - Section 3. Maintenance of the Unit**
 - Section 4. Fault Finding - CF Unit**
- 4. Drawings**
- 5. Certificates**

1. Specification Sheet – nVent Hoffman Purge/Pressurization Units

Model No. (Example):

P CF B 1 YZ

(Note: Not all codes are applicable)

Purge Unit Type

P = Purge/Pressurization Unit

Purging Method

CF = Continuous Flow

Mounting Style

B = Back Plate (Top/Side Mount) 316L
Stainless Steel (NROB finish)

F = Flush Mount (Side/Front Mount) 316L
Stainless Steel (NROB finish)

Size

1 = Purge flow rate 8 scfm, 225 NI / min

Approvals / Certifications

Y = Z =

Europe
EN 60079-0, EN 60079-2,
EN 61241-0, EN 61241-4
Sira 14ATEX1045X

2813  II 2 (2) G D
Ex [py] II T6 Gb
Ex [p] IIIC T85°C Db
Tamb -20°C +55°C

2813  II 3 (2) G D
Ex [pz Gc] IIC T6 Gb
Ex [p Dc] IIIC T85°C
Tamb -20°C +55°C

IEC
IEC 60079-0, IEC 60079-2,
IEC 61241-4
IECEX SIR14.0019X

Ex [py] II T6 Gb
Ex [p] IIIC T85°C Db
Tamb -20°C +55°C

Ex [pz Gc] IIC T6 Gb
Ex [p Dc] IIIC T85°C
Tamb -20°C +55°C

USA / Canada NFPA 496
UL E466718
Class I Div 1
Groups A, B, C & D

Class I Div 2
Groups A, B, C & D

For limitations and conditions of use refer to the applicable certificate at the back of this manual.

Supply Pressure:

60 psi / 0.4MPa / 4 barg must be regulated at inlet.
Maximum supply pressure 115 psi / 0.8MPa / 8 barg.
Compressed Air / Nitrogen

Flow & Pressure Sensors:

One sensor for both
“Low Pressure and Flow” 1 "WC / 250 Pa (2.5 mbarg)

Spark Arrestor Unit:

Purge / Dilution Flow Rate 0.4 to 8 scfm / 10 to 225 NI/min
8 User selectable orifice plates
Material Stainless Steel

Relief Valve

Opening Pressure: 4" WC / 1 kPa (10 mbarg)
Material: 316L Stainless Steel, Spark Arrestor: Stainless Steel mesh, Neoprene Gasket

Action on “Loss of Pressure”: ALARM ONLY

Alarm Switch (Signals)

| | |
|---|---|
| Zone 2 /Division 2 “Alarm”: Dry, VFC, SPSTN/O Contact NI – Ex nA Non-incendive Circuits V _{max} <254 V ac rms I _{max} < 1 A | Hermetically Sealed Switch Ex m IIC T4 Gc V _{max} =254 Vac rms I _{max} 0.7 A |
| Zone 1 or 2 / Division 1 or 2 IS – Ex i circuits U _{max} = 30 Vdc I _{max} 0.7 A | |

2. Application Suitability

nVent Hoffman Purge/Pressurization Units are certified for use in Hazardous Areas, where the Hazardous Area is non-mining (i.e. above ground) and the hazard is caused by flammable gasses, vapors or dust.

Z-Purge Units may be used in IECEx, ATEX Zone 2(22) - Category 3 and NEC 500 Class I, Div 2.

Y-Purge Units may be used in IECEx, ATEX Zone 1(21) - Category 2 and NEC 500 Class I, Div 1.

nVent Hoffman Purge/Pressurization Units may be used for hazards of any gas group. However, apparatus associated with the nVent Hoffman Purge/Pressurization Unit, such as Non-Incendive, Intrinsically Safe signaling circuits and flameproof enclosures containing switching devices may be limited in their gas group. The certification documentation supplied with any such devices must be checked to ensure their suitability.

This unit is designed for use primarily with compressed air. Where other inert compressed gasses are used (Nitrogen, for example) the user must take suitable precautions so that the buildup of the inert gas does not present a hazard to health. Consult the Control of Substances Hazardous to Health (COSHH) data sheet for the gas used. Where a risk of asphyxiation exists, a warning label must be fitted to the Pressurized Enclosure.

The following materials are used in the construction of nVent Hoffman Purge/Pressurization Units. If substances that will adversely affect any of these materials are present in the surrounding environment, please consult nVent Hoffman for further guidance.

Materials of construction:

| | | |
|---------------------|--------------|-----------------|
| Stainless Steel | Aluminum | Acrylic |
| Mild (carbon) Steel | Nylon | Silicone Rubber |
| Brass | Polyurethane | Neoprene |

3. Installation, Operation and Maintenance for CF Units

This nVent Hoffman Purge/Pressurization Unit is designed for use under normal industrial conditions of ambient temperature, humidity and vibration. Please consult nVent Hoffman before installing this equipment in conditions that may cause stresses beyond normal industrial conditions.

The nVent Hoffman Purge/Pressurization Unit shall be installed and operated in accordance with relevant standards, such as IEC / EN 60079-14, NEC 500, NFPA 496 and any local codes of practice that are in force.

For IEC / ATEX applications, references to the NFPA 496 within this instruction manual, should be replaced by the equivalent clause in IEC / EN 60079-2.

For IEC / ATEX applications, the "Example calculations:" in section 1.1.4 within this instruction manual, should read:

If the PE external dimensions indicate a volume of 0.5 m³ (17.7 Ft³) then,

$$\frac{0.5 \text{ m}^3 \text{ (or } 17.7 \text{ ft}^3\text{) enclosure volume} \times 5 \text{ volume changes}}{0.225 \text{ m}^3/\text{min (or } 8 \text{ scfm purge flow rate)}} = 12 \text{ minutes purge time}$$

Installation, Operation and Maintenance Manual for nVent Hoffman Purge/Pressurization Unit Continuous Flow (CF) conforming to NFPA 496

IMPORTANT NOTE It is essential, to ensure conformity with the standard,
that the user of the unit observes the following instructions.

Please refer to the latest standard for detailed requirements and definitions.

Section 0 Description and Principle of Operation

All nVent Hoffman Purge/Pressurization Unit® pressurization units provide:

a) a method of pressurizing a Pressurized Enclosure (PE) while at the same time compensating for any leakage, together with

b) a method of purging the enclosure, before power is turned on, to remove any flammable gas that may have entered the enclosure while it was not pressurized.

Continuous Flow Units, Model CF, allow air to flow through the PE continuously by having a fixed outlet aperture, which does not have any means of closure. The act of pressurizing the enclosure forces air to “leak” through the outlet aperture. The Control Unit admits sufficient air at the inlet to the PE to compensate for the air leaking out of the outlet aperture as well as from any other accidental leakage paths. The flow rate is constant both during purging and thereafter. The Purging Flow rate is monitored by a separate “Purge Flow Sensor” located in the CU, which detects the differential pressure across the purge flow orifice located directly before the Outlet Orifice. The Purge Flow Sensor is set to operate when the desired differential pressure is exceeded. The output from the Flow Sensor is indicated on the CU.

Type **Continuous Flow (CF)** Units are comprised of the following major parts:

- A **Control Unit (CU)** containing as a minimum, for “Y/Z” Pressurization, a Flow Control Valve (LCV), Minimum Pressure and Purge Flow sensing devices, and a “Pressurized”/” Alarm” indicator. The CU supplies a ‘Pressurized’ signal showing whether the PE pressure is satisfactory or not.

- A **Relief Valve (RLV)**, fitted to the PE, to provide a means of limiting the maximum pressure experienced by the PE during operation. All RLVs incorporate a Spark Arrestor to prevent sparks being ejected from the PE through the RLV aperture. The RLV is fitted solely as a safety device and does not open in normal operation.

-An **Outlet Orifice**, which has been pre-calibrated so that the pressure drop at the desired flow rate is known. The Minimum Pressure Sensor within the CU will be set to the same figure as the pressure drop. When the PE pressure exceeds the calibrated pressure, the Continuous Flow must be taking place. The unit is provided with calibrated Outlet Orifices. Where the Outlet Orifice disk is removable and can be easily changed by the user to give different flow rates according to the size of the PE and the available air supply capacity.

Section 1 Installation of the Unit

The installation of the nVent Hoffman Purge/Pressurization Unit, the protective gas supply, any alarm device should be in accordance with the requirements of NFPA 496.

The electrical installation associated with the nVent Hoffman Purge/Pressurization Unit shall conform to the local codes and the relevant clauses of NFPA 496.

1.1 Installation of the nVent Hoffman CF Unit

1.1.1 The nVent Hoffman Purge/Pressurization Unit should be installed either directly on or as close as possible to the Pressurized Enclosure (PE). It should be installed so that the unit indicators may be readily observed.

1.1.2 All parts of any unit carry a common serial number. If installing more than one unit, ensure that this commonality is maintained on each installation.

1.1.3 Any tubing, conduit and fittings used to connect to the PE should be metallic, or, if non-metallic, conform to the local codes for flammability ratings. No valve may be fitted in any tube connecting the nVent Hoffman Purge/Pressurization Unit to the PE.

1.1.4 The user or manufacturer of the PE shall determine the volume of the PE, the necessary purging volume, and the time to be allowed for purging, using the chosen nVent

Hoffman Purge/Pressurization Unit purging flow rate. It is the user's responsibility to verify or enter this data on the PE and/or unit nameplate. Ask nVent Hoffman if in doubt.

Example calculations:

a) If the PE external dimensions give a volume of 20 cubic feet, and it is NOT a motor, multiply the volume by four to get the Purging Volume i.e. 80 cubic feet. Divide the Purging Volume by the purge rate e.g. 32 cubic feet per minute, and round up to the next even minute above, i.e. Purging time would be 4 minutes.

b) If the PE is a motor, multiply the internal free volume by ten to get the Purging Volume. For the example above, purging time would be 8 minutes.

1.1.5 If the PE contains an internal source of release of flammable gas or vapor, the procedures for assessment of the release as given in NFPA 496 shall be observed. The user must verify that the specification of the nVent Hoffman Purge/Pressurization Unit e.g. pressures, continuous flow (dilution) rate and type of protective gas are correct for the specific application.

1.1.6 More than one PE can be protected by a single unit. If PEs are connected and purged in “series” e.g. “Daisy Chained”, the Outlet Orifice must be fitted on the last enclosure with the Purge Inlet to the first enclosure. The RLV

must be fitted to the last enclosure. The bore and length of the tube or conduit used to interconnect the enclosures is critical and will determine the maximum pressure experienced by the first enclosure in the series. Advice on sizing can be obtained from nVent Hoffman. The test pressure for all the enclosures should be 3 times the pressure inside the first enclosure when purging is taking place. If PE's are to be connected in parallel each enclosure must have its own outlet Relief Valve, Purge Flow Sensor and Pressure Sensor.

1.2 Quality and Installation of the Pressurizing Air or Inert Gas Supply

1.2.1 The source of the compressed air must be in a non-classified area. Inert gas may be used as an alternative to compressed air.

1.2.2 Unless a supply shut-off valve has been specially fitted within the unit, a valve with the same, or larger, thread size as the Control Unit inlet fitting shall be fitted externally. In addition, for "Y/Z" Pressurization units, a suitable indicator shall be provided.

1.2.3 The tubing and fittings used must conform to 1.1.3 above.

1.3 Provision and Installation of Alarm Devices

nVent Hoffman Purge/Pressurization Units have a Minimum Pressure Sensor set to a pressure of at least 0.1" WC (0.25 mbar). When the PE pressure is above this set point the Sensor produces a positive "Pressurized" signal. This is displayed on a Red/Green indicator. This signal is used to operate an electrical contact for a remote "Alarm", suitable for an Intrinsically Safe circuits, in accordance with nVent Hoffman drawing 89107938 (or for a Non-Incendive circuit in Division 2)

When the enclosure pressure falls below the set point of the Sensor the "Pressurized" signal is removed, i.e. the absence of the signal indicates an "Alarm" ("Pressure Failure") condition. The user must make use of this external alarm facility in accordance with NFPA 496 requirements, if the unit "Alarm" indicator is not located in a place where it can be readily observed.

The Alarm switch will reset, and its contacts can be used to operate a remote electrical alarm.

nVent Hoffman application tip: Exception: For a "Z Purge" Unit fitted in a Division 2 area, a non-classified switch inside the PE can be used to operate a remote Alarm provided its electrical supply comes from within

the PE (i.e. NOT PROVIDING DRY CONTACTS). When the PE power is switched off there is no need for an alarm.

1.4 Power Supplies and their Isolation

1.4.1 All power entering the PE shall be provided with a means of isolation. This requirement also applies to any external power sources that are connected to "dry contacts" or "volt-free contacts" within the PE. Exception: Power to Intrinsically Safe, or other apparatus, which is already suitable for the location, need not be isolated by the nVent Hoffman Purge/Pressurization unit. When utilizing "Y/Z" Pressurization the power may be controlled manually by the user by the use of local isolating switch.

1.4.3 The Power (cut-off) Switch must be approved for the location or located in a non-classified area.

1.4.4 No valves are permitted between the Power Switch and the nVent Hoffman Purge/Pressurization Unit.

1.5 Marking

1.5.1 The nVent Hoffman Purge/Pressurization Unit carries a nameplate and a specification sheet, which give specific data such as serial and models numbers, Pressure Sensor settings, flow rates and purge time.

1.5.2 Other marking, for the PE, required by the standard includes:

"WARNING - PRESSURIZED ENCLOSURE

This enclosure shall not be opened unless the area is known to be free of flammable materials or unless all devices within have been de-energized" "Power shall not be restored after the enclosure has been opened until the enclosure has been purged for ____ minutes at a flow rate of ____."

Note: It is understood that NFPA 496 requires de-energizing of all devices that are not suitable for the hazard, e.g. devices that are not Explosionproof or Intrinsically Safe. For example, an explosionproof anti-condensation heater would not have to be de-energized.

1.5.2 If Inert Gas is used as the Protective Gas and a risk of asphyxiation exists, a suitable warning plate should be fitted to the PE.

Section 2 Operation of the Unit

Initial Commissioning

2.1 Check that the unit has been installed in accordance with Section 1 of this manual.

2.2 Disconnect the supply pipe from the inlet to the Control Unit and blow clean air through for at least 5 seconds per foot of length (15 sec / meter) to remove any debris, oil and condensation.

2.3 Connect a temporary pressure gauge or liquid manometer to the PE or Control Unit "Pressure Test Point", [on the LP Sensor, by the removal of the Red plug - 5/32" (4mm) OD nylon tube].

2.4 Open the supply shutoff valve.

2.5 Adjust the Flow Control Valve (FCV) so that the enclosure pressure rises to the point where the "Pressurized" indicator turns Green.

2.6 Continue to raise the PE pressure until the Relief Valve (RLV) opens. Verify that the RLV opens at or below the figure specified in the documentation. Repeat the test several times.

2.7 Lower the PE pressure until the "Pressurized" indicator

turns Red. Verify that the indicator turns Red at or above the pressure specified in the documentation. Check the external alarm contacts.

Note: On nVent Hoffman CF units the Minimum Pressure Sensor set point may be significantly above the minimum of 0.1wc (0,25 mbarg) since it doubles as both the Pressure and the Purge Flow Sensor Set points of 1"wc (2.5 mbarg) are common. Please check the documentation for the actual setting.

2.8 Open the FCV again and set the PE pressure to a level somewhere between the Minimum Pressure Sensor set point and the RLV opening pressure. The "working" pressure is not critical. Enough pressure to keep the "Pressurized" indicator Green is sufficient.

2.9 On Y/Z nVent Hoffman Purge/Pressurized Units the purge timing and power control is preformed manually by the User. **Never turn on the power without purge first, unless you have proved that the interior of the PE is gas free and check that the "Pressurized" indicator is green!**

2.10 After initial commissioning, the unit is ready for normal operation.

2.11 Y/Z nVent Hoffman Purge/Pressurization Units are started and stopped by the shutoff valve but the User must close the Power Switch only after the enclosure has been pressurized and the purge sufficient to ensure that the interior of the enclosure is gas free. The power should be shut off as soon as possible after a pressure failure. This is also the User's responsibility.

2.12 "Y/Z" purge units do not control the enclosure power. It is the responsibility of the user to switch off the power whenever the enclosure pressure falls below the minimum permitted i.e. when the "Pressurized" indicator turns Red.

2.14 Normal Operation

2.14.1 Turn the air supply valve On or Off to start or stop the unit,

2.14.2 The user must close the Power Switch only after the enclosure has been pressurized and purged sufficiently to ensure that the interior of the enclosure is gas free. It is the user's responsibility to shut off the power, as soon as possible after a pressure failure.

Section 3 Maintenance of the Unit

The maintenance recommended for the unit consists of the following, supplemented by any additional local requirements imposed by the authority having jurisdiction.

3.1 Initial Maintenance

nVent Hoffman recommends that the commissioning test be repeated at least every six months. They include checking the opening pressure of the Relief Valve, setting of the Minimum Pressure Sensor, and the "Normal Working Pressure" of the enclosure. In addition, the following checks are also recommended at that time:

- Check the RLV and any other Spark Arrestors. Remove any debris or corrosion or replace the Spark Arrestor with a spare.

- Check the condition of the air supply filter element. Clean or replace it as necessary.

3.2 Routine Maintenance

At least every two years, the following additional checks are recommended:

- Apparatus is suitable for the Hazardous Location
- There are no unauthorized modifications
- The source of air is uncontaminated
- The interlocks and alarms function correctly
- Approval labels are legible and undamaged
- Adequate spares are carried
- The action on pressure failure is correct

Section 4 Fault Finding – CF Unit

4.1 General

If the unit does not behave in the manner described above, there is a fault. Some of the more likely faults are dealt with below. If a cure cannot be affected by following the procedure shown below, please call nVent Hoffman or your supplier for further assistance. The unit has been designed for ease of fault finding and many of the components fitted are plug-in or sub-base mounted. Check components by substitution only after establishing that such action is necessary. If the unit is less than 12 months old, parts under warranty should be returned to nVent Hoffman for investigation, with a full report of the fault and the unit Serial number. NOTE: As with any pneumatic unit the greatest enemies are water, oil and debris in the air supply. For this reason, a dust and water filter should always be fitted. But debris can enter from other sources and it is vital therefore that the procedure described in Section 2 is carried out before using the unit for the first time or following any disconnection of the pipework. Failure to perform this work

may cause damage, which will not be covered under warranty.

Fault Finding NOTE: Before making the following checks, verify that the main supply pressure is between 60 and 115 psi (4-8 bar) at the Control Unit.

4.2 Minimum Pressure Alarm is ON Continuously ("Pressurized" Indicator is Red)

Possible cause 1: The Pressurized Enclosure (PE) pressure is too low. Try increasing the setting of the Flow Control Valve (FCV) to raise the pressure in the PE. This is accomplished by turning the FCV in a counterclockwise direction.

Possible cause 2: Enclosure fault?

- Is the ACTUAL PE pressure below the setting of the Minimum Pressure Sensor? Check it with a manometer or gauge.

- is the Outlet Orifice fitted correctly?

- Is there debris stuck on the face of the Relief Valve (RLV) disk, perhaps held there because of the magnetic material?

- Has the PE door been closed, and all conduit/cable glands sealed?

- Is the PE leaking too much?

Possible cause 3: Air supply fault?

Insufficient purge Flow due to inadequate air supply pressure/flow. Check the air supply pressure **at the inlet to the CU** when flow is taking place. Excessive pressure drop in the supply pipe is very common cause of this problem. The supply pipe must be at least as big as the CU inlet fitting, i.e. at least ½" NB.

Possible cause 4 : Excessive PE Leakage ?

Check around the PE when flow is taking place. Any significant leakage must be cured. Has a Leakage Test been completed? The total leakage should not exceed 10% of the Continues Flow rate.

Possible cause 5: PE not strong enough?

Repeat the PE Pressure Test. FM recommend that the PE is tested to three times the Relief Valve opening pressure e.g. 12" wc (30 mbarg) for standard units. Has this test been done?

Possible cause 6: Unit fault?

Has the pressure sensor tube been damaged?

If checks above reveal that the PE is correct, the fault probably lies in the Control Unit. The basic operation of the Minimum Pressure Sensor can be checked by unscrewing the 2.4" (60mm) diameter diaphragm and, by using a finger, block the threaded hole in the top of the valve module. The valve should operate, and the indicator should turn Green. If this works correctly and the enclosure pressure is above the setting of the Minimum Pressure Sensor it is likely that the Pressure Sensor diaphragm needs re-calibrating or replacing. (See 4.6)

4.3 Relief Valve Opens (Continuously or Intermittently)

Possible cause 1: The PE pressure is too high. The Flow Control Valve (FCV) is too far open. Adjust the FCV as described in Section 2 above.

Possible cause 2: Debris on the RLV disk allowing air to leak from the valve. Remove the RLV cover and clean the valve disk. The disk and spring may be removed from the RLV without affecting the calibration.

4.4 "Purging" Indicator Will Not Turn Green During Purging

Possible cause 1: Insufficient purging Flow due to inadequate air supply pressure. Check the air supply

pressure at the inlet to the CU when flow is taking place. Excessive pressure drop in the supply pipe is a very common cause of this problem. The supply pipe must be at least as big as the CU inlet fitting, i.e. at least ½" NB (12 mm).

Possible cause 2: Excessive Pressurized Enclosure (PE) leakage. Check around the PE when flow is taking place. Any significant leakage must be cured. Has a Leakage Test been done? The total leakage should not exceed 10% of the Purge Flow Sensor setting. Check for leakage down the conduit through unsealed stopping boxes.

Possible cause 3: PE not strong enough. Repeat the PE pressure test. It is recommended that the PE is tested to three times the Relief Valve opening pressure e.g. 12" WC (30 mbar) for units with default settings.

Possible cause 4: The tubing from the RLV Flow Sensing point to the Purge Flow Sensor is not air-tight e.g. fitting nuts not tightened or tube damaged. Check and repair as necessary.

Possible cause 5: The Purge Flow Sensor is not operating correctly or out of calibration. The basic operation of the Purge Flow Sensor can be checked by unscrewing the 2.4" (60 mm) diameter diaphragm and by using a finger, block the threaded hole in the top of the valve module. The valve should operate, and the indicator turn Yellow. If this works correctly and the flow through the Relief Valve is above the minimum required WITH THE RELIEF VALVE COVER FIRMLY SECURED IN PLACE, the Sensor diaphragm needs re-calibrating or replacing.

4.5 Pressure Sensor Calibration

If it is decided that the Minimum Pressure Sensor / Purge Flow Sensor needs re-calibrating it can either be returned to nVent Hoffman for this service or it can be done by the user as follows:

Disconnect the pressure sensing pipe from the top of the diaphragm. (It is a "push-in" quick release fitting; firmly push inwards the collar surrounding the pipe where it enters the fitting, and then pull the pipe outwards while maintaining the pressure on the collar). Unscrew the 2.4" (60 mm) diameter diaphragm housing from the top of the Sensor. Invert it and note the brass adjusting screw in the center. Turning the screw inwards (clockwise) will lower the setting. It is likely that the screw will be very stiff due to the locking sealant. If the screw cannot be moved the application of gentle heat in the area of the brass screw can often help. DO NOT OVERHEAT!

4.6 Filter Cleaning

If the filter element needs cleaning the transparent bowl can be unscrewed and removed. The filter element also unscrews and can then be cleaned in soapy water. Do not use solvents on any part of the filter assembly.

It is sometime easier, if the bowl is very tight; to remove the filter by undoing the fitting that holds the filter into the Control Unit.

4. Drawings

Quick Installation Guide – PCFB1YZ

1. With aid of supplied mounting template, cut mounting holes into enclosure. Ensure that Control Unit and Relief Valve are diagonally opposed.
2. Fix Control Unit to enclosure
3. Fix Relief Valve to enclosure
4. For Continuous Flow units only, select orifice for required purge flow rate and fit into Spark Arrestor with circle-clip. Fix Spark Arrestor to Enclosure ensuring that Control Unit and Spark Arrestor are diagonally opposed.
5. Connect output (dry contact alarm) as required
6. Connect isolated air supply to Control Unit
7. Ensure enclosure door is closed, fully latched and free of leaks
8. Turn on 60 PSIG (4 bar) air supply (115 PSIG/8 bar max)
9. Slowly increase Flow Control Valve until Alarm Indicator turns from RED to GREEN
10. After Purge time has been completed power can be applied to the enclosure
11. Refer to manual for assistance

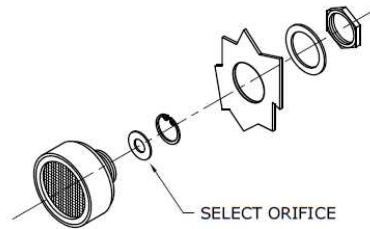
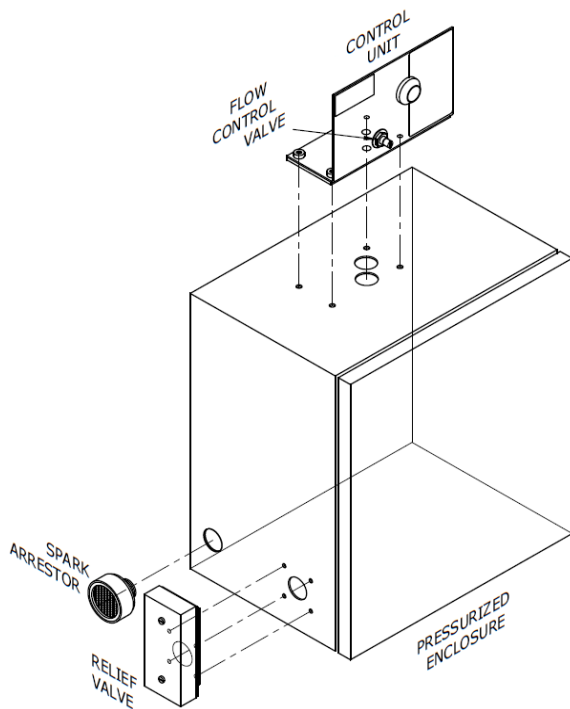

PCFB1YZ

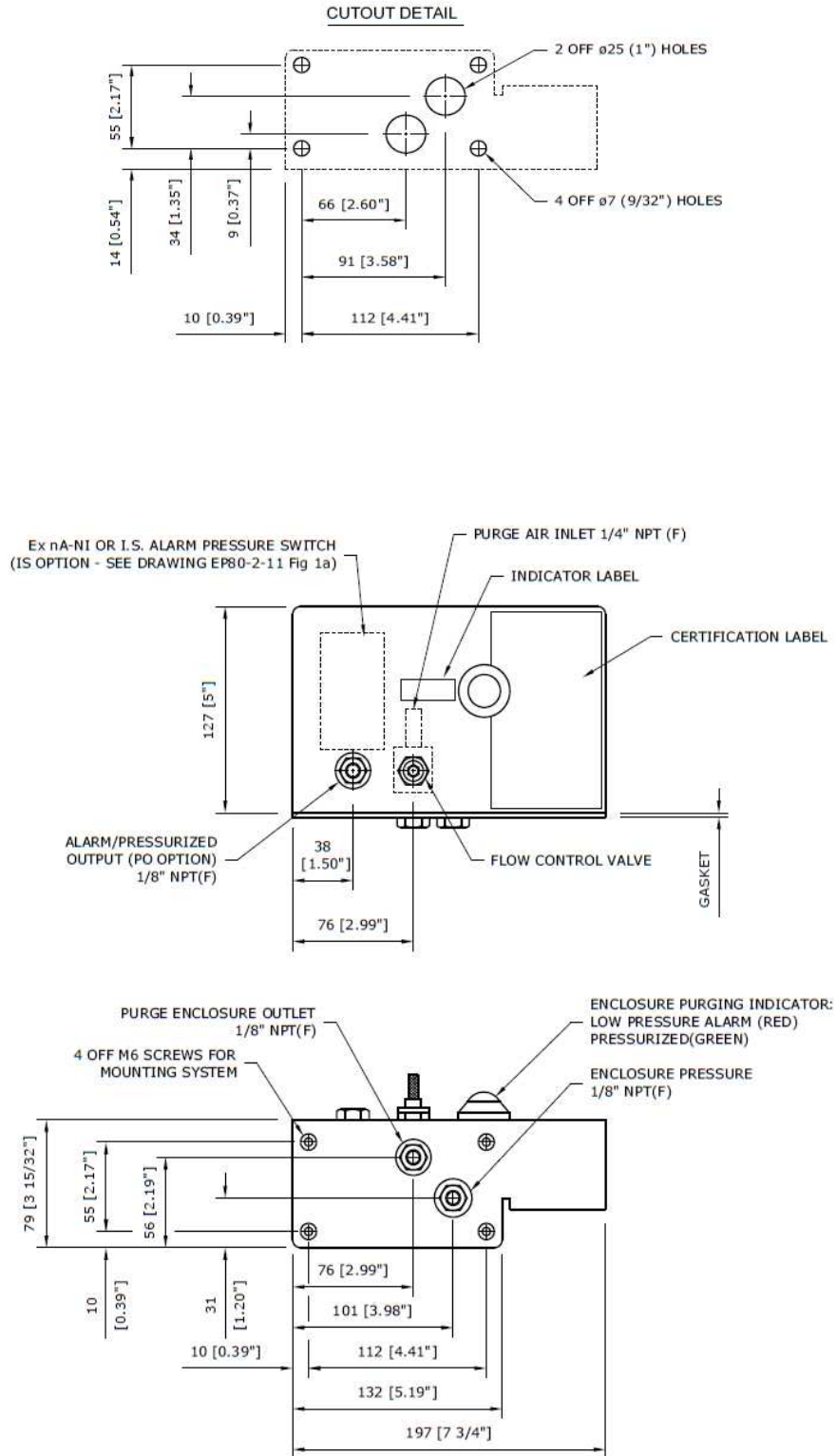

Quick Installation Guide – PCFF1YZ

1. With aid of supplied mounting template, cut mounting holes into enclosure. Ensure that Control Unit and Relief Valve are diagonally opposed.
2. Fix Control Unit to enclosure
3. Fix Relief Valve to enclosure
4. For Continuous Flow units only, select orifice for required purge flow rate and fit into Spark Arrestor with circle-clip. Fix Spark Arrestor to Enclosure ensuring that Control Unit and Spark Arrestor are diagonally opposed.
5. Connect output (dry contact alarm) as required
6. Connect isolated air supply to Control Unit
7. Ensure enclosure door is closed, fully latched and free of leaks
8. Turn on 60 PSIG (4 bar) air supply (115 PSIG/8 bar max)
9. Slowly increase Flow Control Valve until Alarm Indicator turns from RED to GREEN
10. After Purge time has been completed power can be applied to the enclosure
11. Refer to manual for assistance

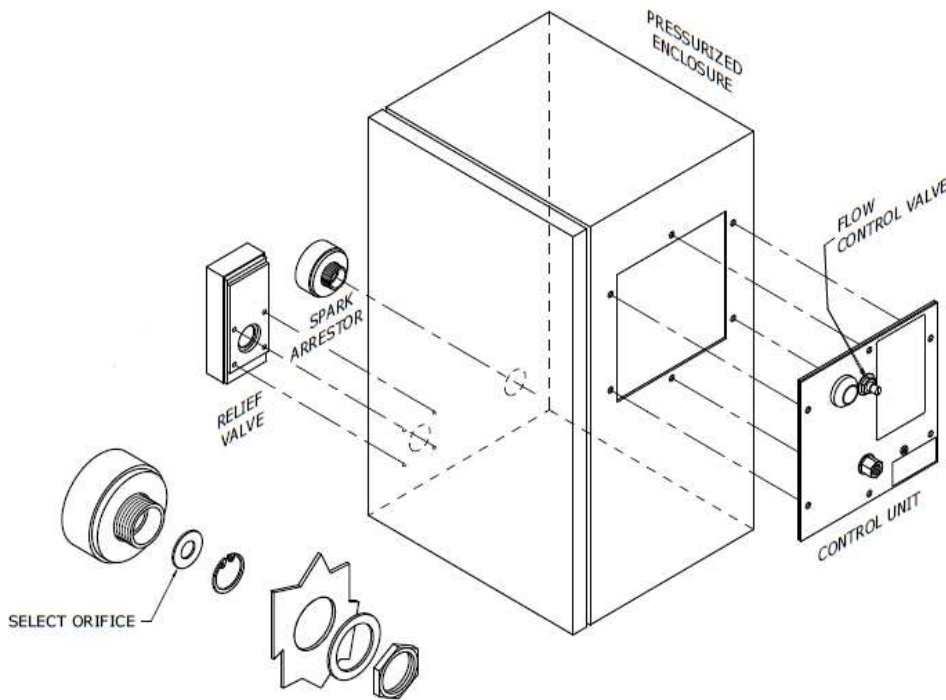

PCFF1YZ

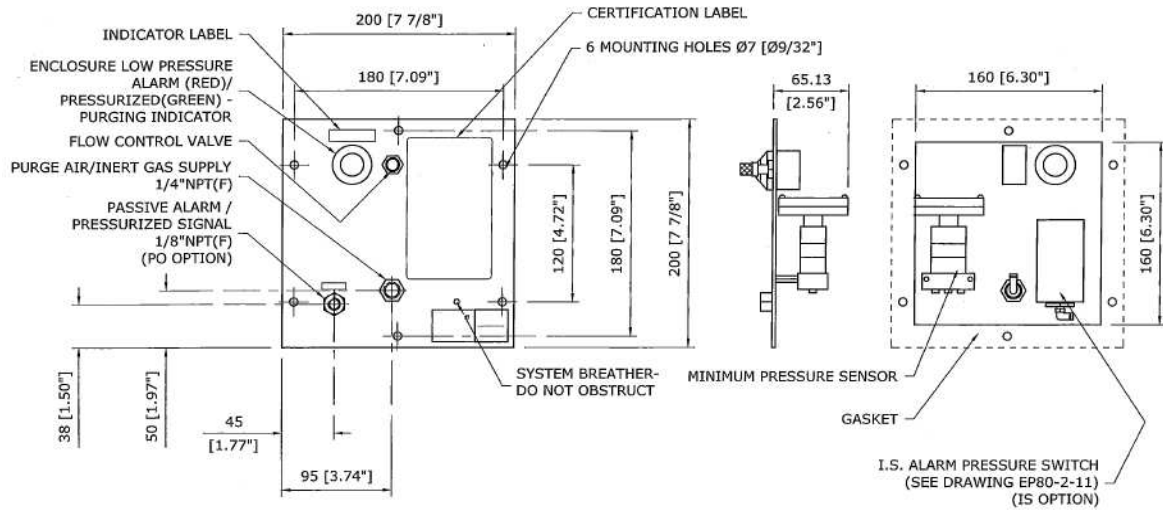

Spark Arrestor/Orifice

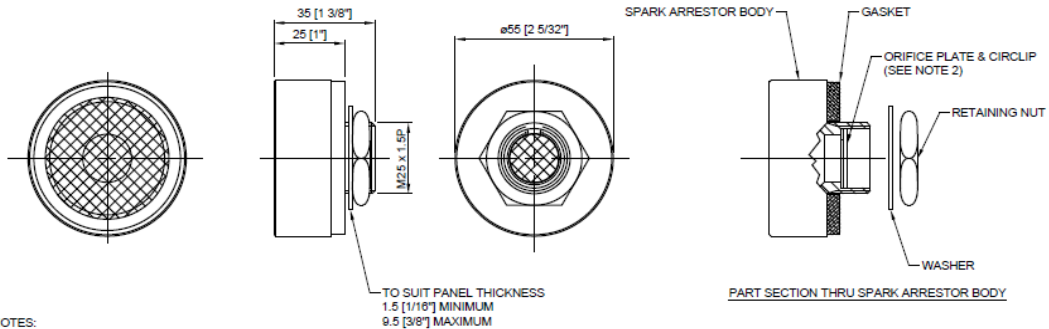

NOTES:

- 1 TO ENSURE EFFECTIVE PURGING THE SPARK ARRESTOR SHOULD BE LOCATED ON THE PRESSURIZED ENCLOSURE AS FAR AWAY AS PRACTICABLE FROM THE PURGE AIR INLET.
- 2 FLOW RATE SELECTION:
 THE FLOW RATE OF THE CONTINUOUS FLOW SYSTEM MAY BE CHOSEN BY THE USER BY SELECTING THE REQUIRED ORIFICE PLATE. FOR RANGE OF FLOW RATES SEE TABLE OF VALUES OPPOSITE.
- 3 ASSEMBLY INSTRUCTIONS:
 - i DECIDE UPON THE REQUIRED FLOW RATE.
 - ii SELECT THE REQUIRED ORIFICE PLATE.
 - iii INSTALL THE PLATE IN THE SPARK ARRESTOR BODY AND RETAIN WITH THE CIRCLIP.

RECOMMENDED MOUNTING HOLE ø28 [1"]
 WEIGHT: 0.25kg [0.55lb]

| SELECTION OF ORIFICE PLATE | | | | |
|--|------------|--------|------------------|----------|
| BASED ON A PURGE SUPPLY OF 4 barg [60 psi] & ENCLOSURE PRESSURE OF 2.5 mbarg [1" WC] | | | | |
| ORIFICE PLATE No | PURGE FLOW | | ENCLOSURE VOLUME | |
| | scfm | NI/min | ft³ (4VC) | m³ (5VC) |
| 1 | 0.4 | 10 | 3.0 | 0.08 |
| 2 | 0.9 | 25 | 8.3 | 0.15 |
| 3 | 1.4 | 40 | 10.5 | 0.24 |
| 4 | 2.3 | 65 | 17.2 | 0.39 |
| 5 | 3.2 | 90 | 24 | 0.54 |
| 6 | 4.8 | 135 | 36 | 0.81 |
| 7 | 6.4 | 180 | 48 | 1.08 |
| 8 | 8.0 | 225 | 60 | 1.35 |

NI/min = NORMAL LITRES/MINUTE
 scfm = STANDARD CUBIC FEET/MINUTE
 * VC = VOLUME CHANGES (BASED ON 30min PURGE TIME)

Relief Valve Drawing

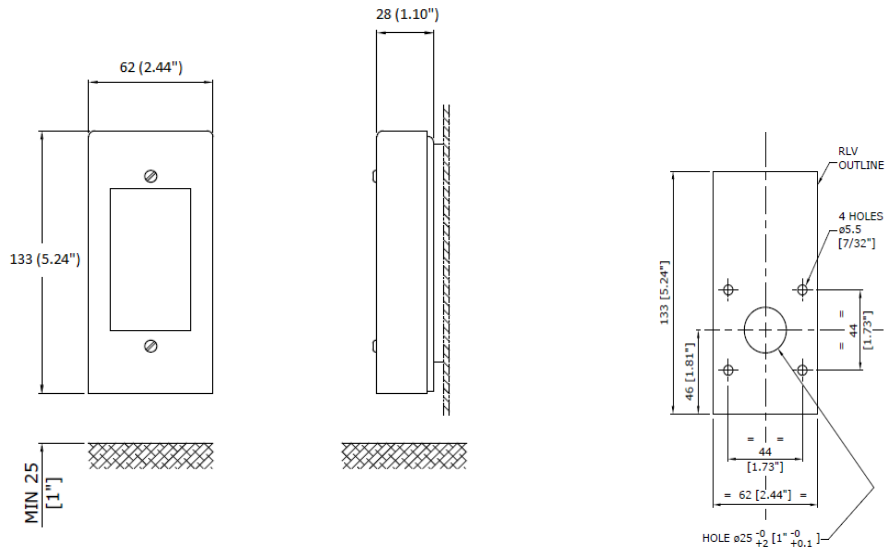

Relief Valve Position

Relief Valve Cutout

Schematic for both PCFB1YZ and PCFF1YZ

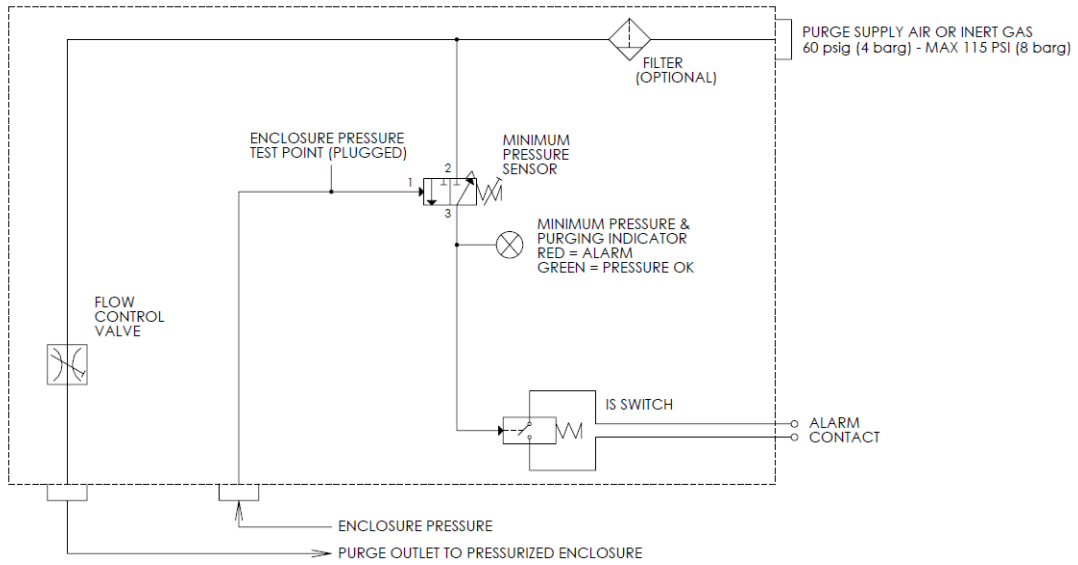
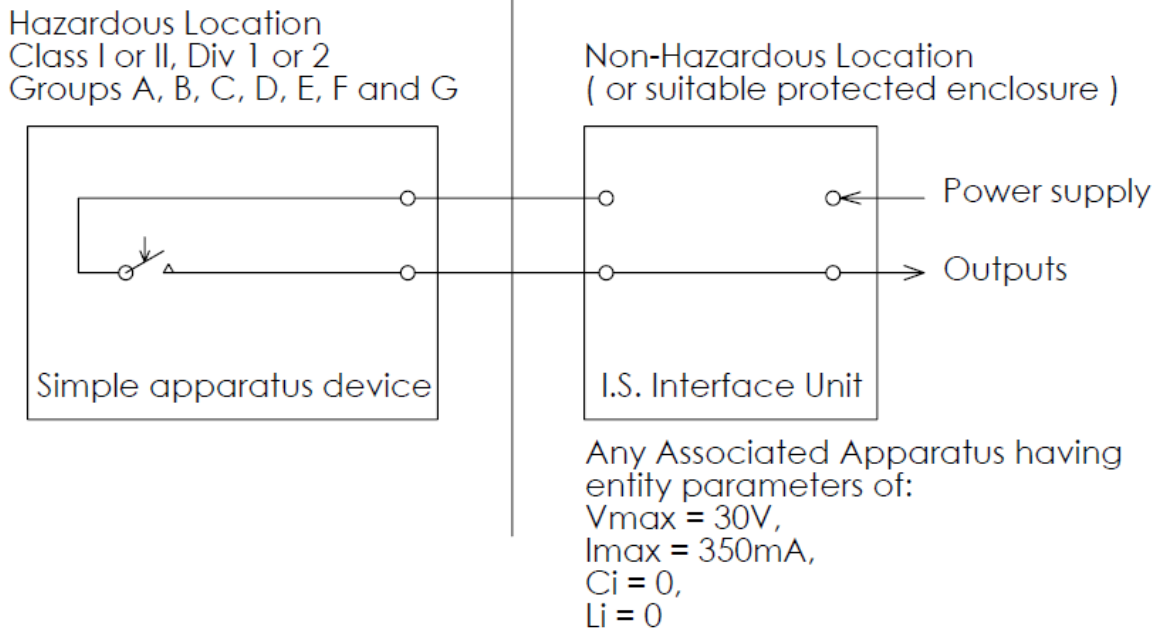

Fig 1 Single channel interface circuit
e.g. "Y" or "Z" Pressurization Alarm circuit



Alarm Switch (Signals)

Zone 2 /Division 2
 "Alarm": Dry, VFC, SPSTN/O Contact
 NI – Ex nA Non-incendive Circuits
 $V_{max} < 254$ V ac rms
 $I_{max} < 1$ A

Hermetically Sealed Switch
 Ex m IIC T4 Gc
 $V_{max} = 254$ Vac rms
 $I_{max} 0.7$ A

Zone 1 or 2 / Division 1 or 2
 IS – Ex i circuits
 $U_{max} = 30$ Vdc
 $I_{max} 0.7$ A

Notes for Fig 1 Single channel interface circuit

- 1 Electrical equipment connected to associated apparatus should not use or generate more than 250 volts
- 2 Installation shall be in accordance with the manufacturer's instructions and Article 504 of the NEC (ANSI/NFPA 70)
- 3 For guidance on Installation see ANSI/ISA RP12.6, (Installation of IS Instrument Systems in Class I Hazardous Locations)
- 4 V_{oc} or V_t of associated apparatus is less than V_{max} I_{sc} or I_t of associated apparatus is less than I_{max}
 C_i plus capacitance of interconnecting cabling is less than C_a of the associated apparatus
 L_i plus inductance of interconnecting cabling is less than L_a of the associated apparatus
- 5 "Simple Apparatus" is a device that will not generate or store more than 1.2V, 0.1A, 25mW or 20uJ
- 6 In Div 2 the circuit connected to the switch may be alternatively be Non-incendive in accordance with NFPA70 Art 500-4(f)(1)

Hoffman Enclosures, Inc.

2100 Hoffman Way
Anoka, Minnesota 55303-1745 USA
Phone: 763 422-2211

P/N 89108870 Dwg 89109562 A