

TWO-STAGE COOLING

Under normal operation, the first stage cooler (the cold air outlet that is nearest to the compressed air inlet) will activate first. This will either reduce the rate of temperature rise in the enclosure, or it will begin to reduce the enclosure temperature (depending on the heat load in the enclosure). If the heat load is significant, and the temperature continues to rise, the second stage cooler will activate, doubling the amount of cooling air. In locating the two Cold Air Ducting Kits, consideration should be given to the two-stage cooling capability of the unit. The two cold air outlets and ducting kits provide for increased flexibility in directing refrigerated air in the enclosure. For example, the first stage output could be directed at a primary source of heat within the enclosure and the second stage output could be routed for overall distribution of cold air throughout the enclosure. This configuration might allow the first stage to mitigate the heat, reducing the need or operating time for the unit to run at full cooling capacity and therefore conserving energy. Or, you may want to direct the cold air from the first stage to a heat sensitive component to ensure maximum thermal protection of that component.

TROUBLESHOOTING

Insufficient cooling may be caused by the following:

1. Undersized compressed air line size.
2. Compressed air pressure at the product is too low.
3. Partial or complete blockage of internal compressed air paths, due to dirt.
4. Water vapor in the compressed air supply.
5. Loose cold air outlet fitting(s). This may occur if not tightened properly after being disassembled for cleaning.

If trouble persists, please contact nVent Hoffman for assistance, phone #763.422.2211.

LIMITED WARRANTY

nVent Hoffman products will be replaced or repaired if found to be defective due to manufacture within one year from the date of invoice. nVent Hoffman makes no specific warranty of merchantability or warrant of fitness for a particular purpose.

TABLE 1: FILTER RECOMMENDATIONS

FILTER AND REPLACEMENT PART ITEM NUMBERS		
Hoffman Model #	Oil Removal Filter	Replacement Generator Kits (5 pc)
VA501604X	VC-OF25	VAGK25

TABLE 2: DETERMINING COMPRESSED AIR LINE SIZE

1. Calculate total product compressed air consumption (SCFM, SLPM).
2. Determine length of compressed air line required for connection to main supply.
3. Locate pipe length in left column and read to the right to find the compressed air requirements.
4. Locate pipe size at top of column.

MAXIMUM AIRFLOW (SCFM) THROUGH PIPE AT 5 PSIG PRESSURE DROP (100 PSIG AND 70°F)									
Pipe Length (Feet)	Pipe Size (Nominal) - Schedule 40								
	1/4	3/8	1/2	3/4	1	1-1/4	1-1/2	2	2-1/2
10	29	65	120	254	480	978	1483	2863	4536
20	21	46	85	180	340	692	1049	2024	3208
30	17	37	70	147	277	565	856	1653	2619
40	15	32	60	127	240	489	792	1431	2268
50	13	29	54	114	215	437	663	1280	2029
60	12	26	49	104	196	399	606	1169	1852
70	11	25	46	96	181	370	561	1082	1715
80	10	23	43	90	170	346	524	1012	1604
90	10	22	40	85	160	326	494	954	1512
100	9	21	38	80	152	309	469	905	1435

MAXIMUM AIRFLOW (SLPM) THROUGH PIPE AT 0.3 BAR PRESSURE DROP (6.9 BAR AND 21°C)									
Pipe Length (Meters)	Pipe Size (Nominal) - Schedule 40								
	1/4	3/8	1/2	3/4	1	1-1/4	1-1/2	2	2-1/2
3	821	1840	3396	7188	13584	27677	42117	81023	128369
6	594	1302	2406	5094	9622	19584	29687	57279	90786
9	481	1047	1981	4160	7839	15990	24225	46780	74188
12	425	906	1698	3594	6792	13839	20999	40497	64184
15	368	821	1528	3226	6085	12367	18763	36224	57421
18	340	736	1387	2943	5547	11292	17150	33083	52412
21	311	708	1302	2717	5122	10471	15877	30621	48535
24	283	651	1217	2547	4811	9792	14829	28640	45393
27	269	623	1132	2406	4528	9226	13980	26998	42790
31	255	594	1075	2264	4302	8745	13273	25612	40611

Rubber hose maximum airflow rating: 1/2" I.D. rubber hose = 3/8" pipe; 3/4" I.D. rubber hose = 1/2" pipe



HOFFMAN

OPERATION & SAFETY INSTRUCTIONS

VORTEX A/C ENCLOSURE COOLER UL TYPE 4/4X

Model VA501604X



IMPORTANT
Please read all instructions **BEFORE**
attempting to use this product

nVent Hoffman

2100 Hoffman Way, Anoka, MN 55303 USA
1.763.422.2211 nVent.com/hoffman

GENERAL SAFETY CONSIDERATIONS

DANGER: COMPRESSED AIR COULD CAUSE DEATH, BLINDNESS OR INJURY.

1. Do not operate a Vortex A/C at compressed air pressures above 150 psig (10.3 bar).
2. Do not operate a Vortex A/C at line temperatures above 110°F (43°C).
3. Avoid direct contact with compressed air.
4. Do not direct compressed air at any person.
5. When using compressed air, wear safety glasses with side shields.

Avvertissements pour Vortex A/C NEMA 4/4X Modèle VA501604X:

ATTENTION! Pour maintenir la norme UL type 4 / 4X: Lorsque monté sur la partie supérieure d'un boîtier, cet appareil doit être installé de sorte que l'entrée d'air comprimé est à l'horizontale. Lorsqu'il est monté sur le côté d'un boîtier, cet appareil doit être installé de sorte que l'entrée d'air comprimé est dirigée vers le bas, vers le plancher.

ATTENTION! Les surfaces extérieures de l'appareil peuvent être chaudes. Éviter le contact.

INTRODUCTION

A Vortex A/C enclosure cooler is designed to use filtered compressed air to cool industrial control cabinets without the use of any refrigerants. Hot air in the cabinet is vented to the surroundings through built-in vents in the Vortex A/C. Noise generated by the Vortex A/C is comparable to normal speech levels. The Vortex A/C has built-in mechanical thermostats that require no electricity. To operate, simply install on your enclosure and connect the compressed air source.

COMPRESSED AIR SUPPLY

The compressed air supply must be filtered (5 micron maximum) to remove water and dirt. A 5 micron filter is supplied for this purpose (Hoffman filter model VAAF50). If oil is present in the compressed air supply, remove the oil using an optional 0.01 micron coalescing filter (Hoffman model VC-OF25). Filter recommendations are given in Table 1.

If an oil removal filter is necessary, install it downstream of the 5 micron filter. Change the filter elements as needed (see Maintenance). The appropriate size of compressed air supply line should be selected to ensure optimal performance of the Hoffman product. Please refer to Table 2 to determine what supply line size is recommended for your application. Contact nVent Hoffman for assistance, phone #763.422.2211.

INTERNAL CABINET PRESSURE

The Vortex A/C, when operating at 100 psig (6.9 bar), will maintain the internal enclosure pressure at approximately 35" (889 mm) of water column. When the Vortex A/C is not cooling (when the thermostats sense acceptable temperatures), the Vortex A/C is not pressuring the enclosure. If you desire a constant positive

internal enclosure pressure, even when the Vortex A/C is not cooling, this may be accomplished by removing two set screws that are adjacent to the mechanical thermostats on the bottom of the unit. By removing both of these set screws with a 3/32" (2 mm) hex key, a small amount of air (6 cfm or 170 lpm) will pressurize the sealed enclosure to approximately 1.5" (38 mm) water column. This "pressurization air" will run continuously, regardless of the thermostat operation, until the set screws are re-installed.

MAINTENANCE

The only maintenance involved with the Vortex A/C is normal element changes to the compressed air filter. The filter element should be changed when there is a noticeable decrease in performance or when pressure drop across the filter exceeds 5 psig (0.3 bar). The Vortex A/C has only two moving parts (the mechanical thermostats/valves) which are not serviceable in the field. Do not disturb the setting of the thermostats. Evidence of tampering with the thermostats may void the warranty.

If it is suspected that the compressed air filter has not been maintained after an extended period of operation, there may be dirt in the Vortex A/C. If the Vortex A/C is not cooling sufficiently, there may be debris in the "generators" of the unit. To check, pull the 1/2" (13 mm) inside diameter vinyl tubing off the cold air outlets of the Vortex A/C and unscrew (with a 1" (25 mm) open end wrench) the cold air outlets. Remove the O-rings. Remove the white nylon washer(s). Then remove the brown generators. Inspect the six slots in the generators for dirt and clean if necessary. Clean the cavities in the Vortex A/C that the generators were located in if necessary. Reassemble in reverse order. Tighten the cold air outlets to 100 inch-pounds (11 newton meters) torque. Be sure to supply clean (filtered to 5 micron) and oil free compressed air to the Vortex A/C.

INSTALLATION

To maintain the UL Type 4 and 4X rating, the Vortex A/C MUST be installed in one of the following configurations on a UL Type 4 or 4X enclosure:

- a. Top mounted in an upright and vertical orientation, on a flat horizontal surface (as shown)
 - b. Side mounted, on a flat vertical surface of the enclosure, with the compressed air inlet pointing downward, or with the stainless steel shroud facing downward to the floor. If side mounted, locate the Vortex A/C so that it is near the top of the enclosure.
1. Position the Vortex A/C on the top or side of your enclosure so that there is sufficient clearance for the internal mechanical thermostats and cold air outlets, and so that the entire mounting "footprint" of the Vortex A/C is supported by the enclosure. (A 9-1/2" wide x 3-1/2" deep (241 mm wide x 89 mm deep) area). Position the unit so that the metal shroud on the back of the Vortex A/C is away from personnel, if possible. Also, position so that no internal enclosure components obstruct air flow around the mechanical thermostats.
 2. Cut two 1-15/16" (49 mm) diameter holes (1-1/2" knockout size) on 4" (102mm) centers in the selected location on the enclosure. De-burr any sharp edges around these holes.

3. Remove the 1-1/2" electrical locknuts from the Vortex A/C. Insert the threaded portions of the Vortex A/C into the 1-15/16" (49 mm) holes in the enclosure. (Be careful not to damage the mechanical thermostats during installation.)
4. From inside the enclosure, screw the electrical locknuts onto the threads of the Vortex A/C. Tighten the locknuts securely to compress the 1/8" (3 mm) thick sealing gaskets that are positioned between the enclosure and the Vortex A/C.
5. Determine suitable locations for the Cold Air Mufflers inside the enclosure that are close to the cold air outlets of the Vortex A/C. (You will need a surface area of approximately 2" x 9" (50 mm x 229 mm) to mount each muffler. The Mufflers can be mounted in any orientation, horizontal or vertical.) Using the supplied Muffler Mounting Clamps (with double sided tape), attach the Clamps at the desired locations. Clean the mounting surfaces so that the double sided tape bonds securely. If desired, the Clamps can be permanently mounted to the enclosure using the supplied mounting hardware. Two 5/32" (4 mm) diameter holes positioned on 3/4" (19 mm) centers must be drilled to mount the Muffler Clamps. Use the plastic snap rivets to secure the Muffler Clamps to the panel.
6. Snap the Cold Air Mufflers into the Mounting Clamps.
7. Cut a sufficient length of the 1/2" (13 mm) inside diameter vinyl tubing from the supplied VADK124X Cold Air Ducting Kits to connect the cold air outlets of the Vortex A/C to the hose barbs on the Cold Air Mufflers. Attach the lengths of vinyl tubing so that they are free of sharp bends and kinks. Direction of cold air flow through the Mufflers is not important.
8. Attach all (or a portion of) the remaining supplied vinyl tubing of the VADK124X Cold Air Ducting Kits to the opposite hose barb connections on the Cold Air Mufflers. Holes can be punched or drilled into the 1/2" (13 mm) tubing to distribute the cold air evenly inside your enclosure, or, the entire cold air output can be directed to a heat sensitive component. If the end of the 1/2" (13 mm) vinyl tubing is plugged, at least sixteen 1/8" (3 mm) diameter holes should be punched into the tubing to allow the cold air to escape. Use the nine self adhesive tubing clips provided with each kit to mount the tubing.
9. Connect the compressed air filter model VAAF50 to the compressed air inlet on the side of the Vortex A/C with a length of 3/8" pipe and a 3/4" npt x 3/8" npt pipe reducer bushing. Install the compressed air filter as close as possible to the Vortex A/C, in a location where the temperature does not exceed 125°F (52°C). Allow the filter to hang at the side of the enclosure as shown in the installation drawing. Use a 13/16" (21 mm) wrench to hold the air fitting on the side of the Vortex A/C stationary while tightening the pipe connections. Note the air flow direction arrow on top of the filter.
10. Connect the compressed air supply to the inlet of the air filter. See "Compressed Air Supply."

OPERATION

Operate the Vortex A/C at 90 to 100 psig (6.2 to 6.9 bar) compressed air pressure. Do not operate at pressures above 150 psig (10.3 bar). Operation at pressures less than 90 psig (6.2 bar) and above 100 psig (6.9 bar) will effect the operation.

When properly sized for the application, the Vortex A/C will maintain the internal enclosure temperature between 75-100°F (24-38°C). Enclosure temperatures can momentarily reach 125°F (52°C) during initial start-up and after long periods of inactivity. Variations in heat load and compressed air conditions can effect thermostat operation. The mechanical thermostat will regulate an internal valve to minimize compressed air usage and maintain enclosure temperatures within the range specified. In some applications, the Vortex A/C may run continuously at lower air usage with the benefit of always keeping the enclosure under slight internal pressure. In other applications, the Vortex A/C may cycle on and off to maintain enclosure temperatures.

NOTICE: The thermostat's reaction to temperature change depends on several factors: the internal and external heat loads, enclosure size and proximity to the heat source. When the internal heat load is zero (or very low) and when external temperatures are below 50°F (10°C), the thermostat will take longer to react to air temperature increases. There will be a lag between the rising air temperature and when the thermostat reacts, which can result in temperatures inside the enclosure exceeding 125°F (52°C). When air and thermostat temperatures equalize, the reaction to temperature change is improved and the lag is minimized.

CAUTION: The rear metal shroud of the Vortex A/C becomes hot during operation and can remain hot for a period of time after the unit has cycled off. Note warning label precaution, and avoid direct contact with this area of the unit during or after operation.

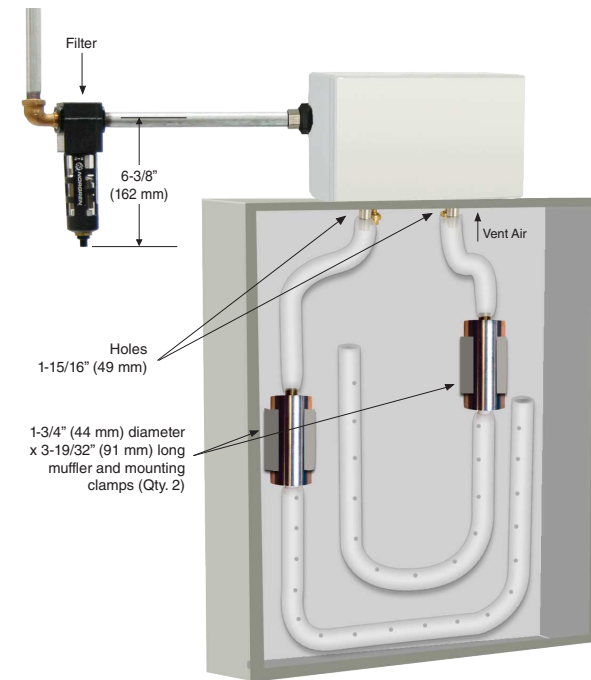

VORTEX A/C TYPE 4/4X
(SHOWN TOP MOUNTED ON CUSTOMER'S ENCLOSURE)