



OPERATION & MAINTENANCE MANUAL

October 2011

TABLE OF CONTENTS

Introduction 1
 Score-TRICENTRIC® Valve History & Operating Principle ... 1
 Score-TRICENTRIC® Stop Valve Standard Features 1
 Score-TRICENTRIC® Valve Definitions 1
 Principles Of Operation 2
 Receipt of Valves 2
 1. Receipt Inspection 2
 2. Storage 2
 3. Shelf Life 2
 4. Tool Requirements for Installation and Maintenance ... 2
 CAUTIONS 2
 Orientation 3
 Left Hand Mounting of Actuator 3
 Right Hand Mounting of Actuator 3
 Gear Orientation 3
 Differential Pressure Direction 4
 Shaft Orientation 4
 Actuator Supports 4
 Valve Lifting Location 4
 Flange Face Alignment 4
 Flange Hole Alignment 4
 Structural Loading/Bending Strength 4
 Piping Supports 4
 Installation 4
 Maximum flange bolt torque table 5
 Torque Sequence 6
 Maintenance 6
 Valve Removal 6
 Disc Seal Replacement Procedure 6
 Removal of Clamp Ring 6
 Removal of Seal Stack 7
 Installing New Seal Stack 7
 Re-Install the Seal Stack 7
 Re-Install the Clamp Ring 8
 Floating the Disc Seal 6
 Changing The Packing. 9
 Valve Disassembly 9
 Valve Assembly 10
 General Information For Sizing, Setting and Installation of Actuated Valves 11
 Actuator Mounting And Adjustment 11
 Pneumatic Fail Open Service 12
 Actuator Safety 12
 Manual Gear Actuators 12
 Electric Motor Operated Manual Gear Operator 12
 Pneumatic Actuator 12
 Actuator Maintenance 12
 Trouble Shooting 12

Procedure For Torquing Threaded Fasteners 13
 Torque Guide 13
 ANSI Flange Bolt Dimensions for Lug style valves 14
 ANSI Flange Bolt Dimensions for Wafer style valves 15
 ANSI Flange Bolt Dimensions for Double Flange style valves 16
 Parts Map / Standard Tricentric Valve 17
 Parts Map / Standard Tricentric Valve with Cryogenic Extension Back Cover

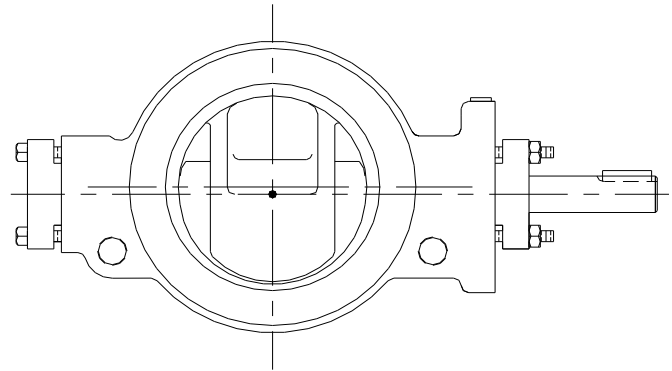

Wafer Style Valve

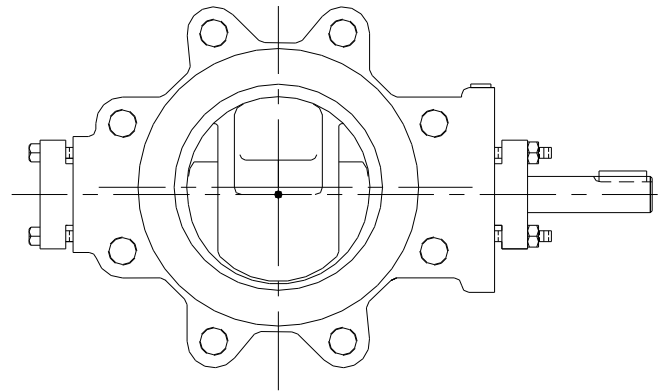

Lugged Style Valve

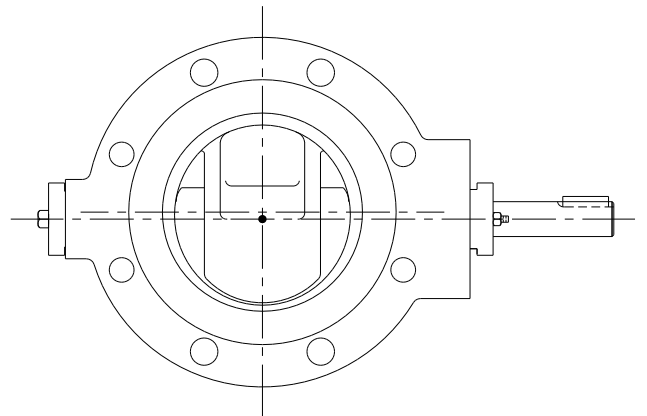

Double Flanged Style Valve

INTRODUCTION

Score-TRICENTRIC® Valve History & Operating Principle

The Score-TRICENTRIC® valve is a metal seated butterfly type which is designed and manufactured in a manner that allows the disc to rotate into and out of the seat with absolutely no interference. This results in a sealing system that, unlike butterfly valves which depend upon interference to effect a seal, is damaged by abuse rather than use. Under normal operating conditions with relatively clean fluids, the Score-TRICENTRIC® sealing capabilities actually improve with use, and offer a lower leakage than it exhibited on the test stand.

The geometry of the sealing system is that of two matching conical zones which must be carefully mated to each other and coupled to the remainder of the working elements in order to achieve the non-interfering characteristics desired. The critical dimensions are the angle of the cone and its relationship to the centre line of the piping, the major and minor axes of the ellipse formed by cutting the cone at an acute angle to its axis, the seal stack thickness, and the location of the shaft axis relative to the elliptical surface. There is a unique curve determined from the geometry of each Score-TRICENTRIC® which suggests the zone within which the shaft axis must be located. Proper positioning results in a greater offset from the seal centre than that of competitive designs. This, along with the fact that a metal seated valve of this type will require greater forces to be generated at the sealing interface, results in a greater torque requirement to operate it than that of competitive products.

Another important aspect of the design is that the apex angle of the cone exceeds the friction angle of any material couple which may be used for the seal and seat. This also results in a non-jamming feature which prevents the type of problem experienced with gate valves that have been closed for long periods, and are damaged by attempts to open them.

During manufacture, the seal and seat are machined to the conical shape utilizing single point tooling which yields a "less than perfect" surface. As the valve is used, these imperfections are flattened, and the impression of the seal laminations appears on the valve seat. This is the reason that the sealing capability improves with use. Only mechanical damage to the sealing elements will result in excessive leakage.

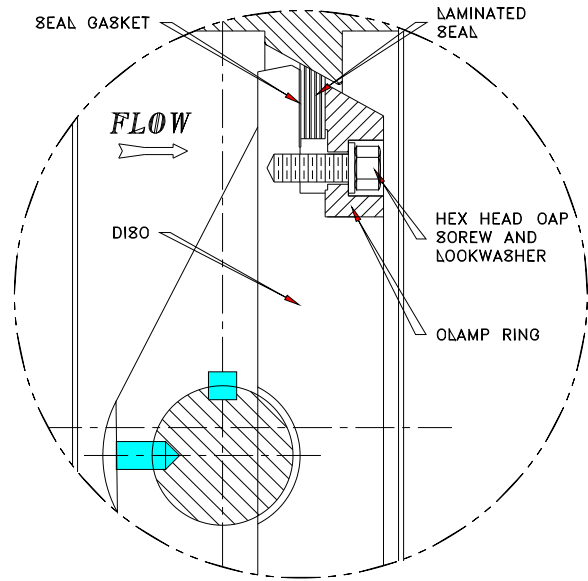

Score-TRICENTRIC® Stop Valve Standard Features

- Metal-to-metal sealing system consisting of a solid seat in the body and a laminated seal stack clamped in the disc assembly.
- The seal and seat are each machined to the same conical surface, and are adjusted in assembly so as to achieve the best possible match-up of the mating parts.
- The Score-TRICENTRIC® is torque seated and shut-off actually improves with use of the valve. This is due to the unique compressive action during closure which does not rely on interference or friction.

Score-TRICENTRIC® VALVE DEFINITIONS

In addition to normal valve nomenclature, there is additional verbiage used by the factory to describe various points on the component parts. These points of reference are concerned with the centre lines of the valve body, and are as follows:

- "A2" The centre line of the disc and valve body, perpendicular to the drive shaft.
- "AH" The point on the disc "A2" centre line, shaft side of the disc, furthest away from the shaft edge.
- "AL" The point on the disc "A2" centre line, shaft side of the disc, closest to the shaft edge.
- "K2" The centre line of the disc and valve body, parallel to the drive shaft.

PRINCIPLES OF OPERATION

Score-TRICENTRIC® valves are designed to isolate or modulate upstream flow through a pipeline. The valve is of a "torque seated" design. This requires the valve to be actuated by an operator capable of producing a minimum seating torque, based on the valve size, and with a minimum of 90 degrees of travel. The term "torque seated" refers to the sealing member of the valve. With the actuator properly adjusted, there shall be no mechanical stop positioning it in the closed position other than the valve seal stack contacting the valve seat with the minimum required torque applied. The stop can then be set at this point to prevent over-torque. The open position of the valve shall be limited by the mechanical open stop of the actuator.

Score-TRICENTRIC®

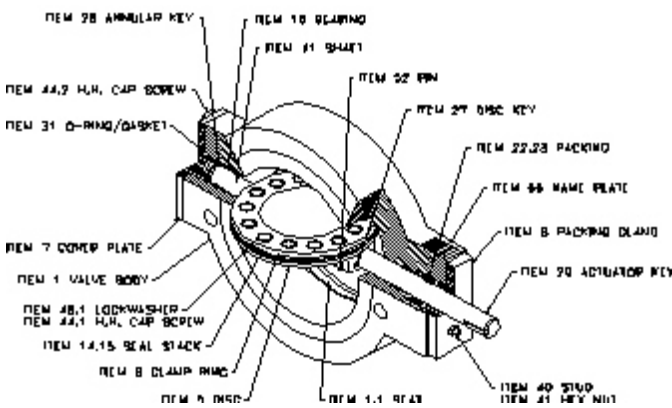

RECEIPT OF VALVES

1. Receipt Inspection

After uncrating the valve, visually check for damage that might have occurred during shipment.

- a. Missing parts. Use assembly drawing for reference
- b. Damage to the machined surfaces of the valve.

2. Storage

When the valve is not put into immediate service, it is required that the valve be stored in a heated building that is fire resistant, weather tight and well ventilated. Storage area shall be situated and constructed so that it will not be subject to flooding.

Any spare parts for the valve shall be stored in the original packaging and under the same conditions as the valve will be stored.

3. Shelf Life

Item	Description	Material	Shelf Life
14	Seal Stack	316/Grafoil, Klingler C4401	15 yrs
15	Gasket	Grafoil, Klingler C4401	15 yrs
23 *	Packing Ring	JC387I	5 yrs
22 *	Packing Ring	Grafoil	5 yrs

* Applies to any Packing type.

All other recommended spare parts will have an indefinite shelf life.

4. Tool Requirements for Installation and Maintenance

All tools required for installation and maintenance are commercially available. Any lifting devices used to move the valve into a desired position shall be of sufficient size to support the weight of the valve/actuator assembly. If it is necessary to lift the valve by any other area of the valve body, other than the tapped holes or the lifting lugs in the valve body, the use of nylon slings (i.e. as manufactured by Lift All, type EE2-803) is recommended to reduce the possibility of mechanical damage occurring to the valve body and actuator. The assembly should never be lifted by the actuator lifting lugs or by a sling around the actuator. These areas are for removal and installation of the actuator to the valve only.

Absolutely NO lifting devices shall ever pass through the valve port since seat and/or seal damage may result.

CAUTIONS

For safety, take the following precautions before removing or installing the valve, or before any disassembly.

1. Know what media is in the line.
2. Line must be depressurized.
3. Wear protective clothing and equipment to avoid injury from the media in the line.
4. THE VALVE MUST BE REMOVED OR INSTALLED IN THE CLOSED POSITION. This will prevent mechanical damage to the disc seal.

ORIENTATION

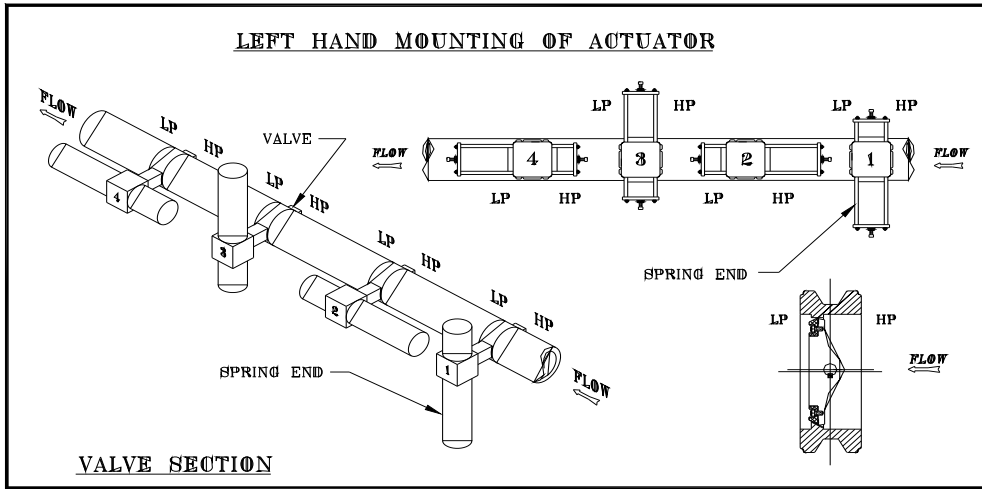

Legend

LP = Low Pressure
HP = High Pressure

Actuator Positioning

1. Perpendicular to pipeline.
2. Parallel to pipeline spring-end upstream.
3. Perpendicular to pipeline.
4. Parallel to pipeline, spring-end downstream.

NOTE:

Right or left hand mounting must be specified when selecting actuator position to the pipeline.

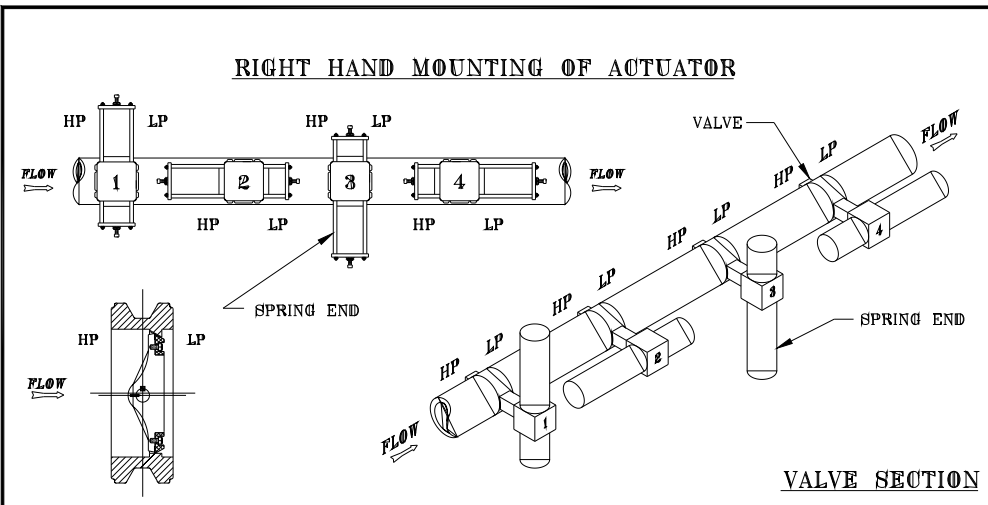

Gear Orientation

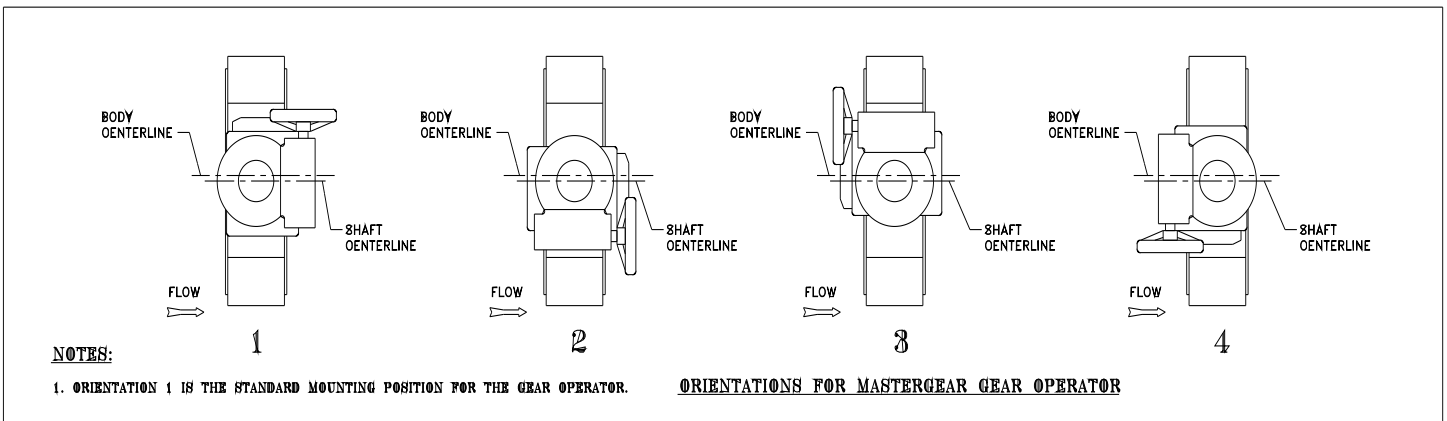

Differential Pressure Direction

The preferred differential pressure direction on installation is such that fluid flow will be in the direction indicated by the flow arrow on the body showing HP and LP side of valve. Special cases of equipment isolation or flow to close control applications may differ.

Shaft Orientation

The preferred shaft orientation is horizontal in order to reduce the deposition of media solids in the valve lower bearing area. If horizontal installation is not possible install as far off vertical as possible.

Actuator Supports

When actuators are used, consideration must be made for the support of the actuator such that the actuator load is not carried through the valve to the piping supports. Score Energy Products requires the use of actuation support in the following case:

- Non-vertical valve shaft orientation with pneumatic, hydraulic or electric actuator.
- Non-vertical valve shaft orientation with cryogenic or heat extension option.

Contact Score Energy Products for specific exception to actuator support requirements.

Valve Lifting Location

Score Energy recommends the following lifting locations:

- For 3" through to 24" valves – Use nylon slings around both body necks as well as actuator (for actuator stabilization).
- For 30" and larger valves – Use integral valve body lifting lug locations as well as actuator lifting lugs (for actuator stabilization).

Any lifting devices used to move the valve into the desired position must be of sufficient size and type to support the weight of the combined valve and actuator assembly. The assembly should never be lifted by the actuator lifting lugs or by a sling around the actuator only. Absolutely no lifting devices shall ever pass through the valve port since seal/seat damage may result.

Flange Face Alignment

"Use care to provide good alignment of flanges being assembled. It should be recognized that if the flanges are not parallel ... it will be necessary to bend something to make the flange joint tight. Simply forcing the flanges together ... may bend the valve" MSS-SP92.

Score Energy points out that optimum valve sealing and function will result from minimized flange face misalignment. A maximum guideline for misalignment should be based on industry standards and application experience. Contact Score Energy for application specific consideration.

Flange Hole Alignment

All considerations discussed above in flange face alignment are also valid for flange hole alignment. A maximum guideline for misalignment should be based on industry standards and application experience – 1/8" offset maximum per ASME B31.3. Contact Score Energy for application specific considerations.

Structural Loading/Bending Strength

Twisting and bending moments as well as combined axial valve loading cannot be accurately predicted mathematically.

"It is therefore recommended design practice to avoid locating valves at points of large bending loads. Bending loads cause deformation in valve bodies which can be detrimental to valve functional performance." MSS-SP-92

The Score-TRICENTRIC® valve should be considered a vessel for piping design. Good piping design practice should be used for stress intensification factors and casting quality factors, per ASME B31.3, in determining allowable piping stresses relative to valve bending loads. Contact Score Energy for application specific considerations.

Piping Supports

Support piping as near to the valve as practicable. Do not hang piping on the valve.

INSTALLATION

****Refer to Parts Map for numbers in ().**

***** NOTE: READ ALL TAGS THAT ARE ATTACHED TO THE VALVE BEFORE INSTALLATION ! *****

Before installation, all rust preventative should be removed using a commercial solvent.

1. Valve must be installed with the disc in the closed position. Check seat (1.1) and disc seal (14) for dirt accumulations and for damage from transit or storage. For proper operation of the valve, the seat and disc seal must be undamaged and free of foreign material. Therefore it is recommended that the valve be cleaned with a suitable solvent and any damage is repaired.
2. If the valve is equipped with a FAIL OPEN actuator, the valve must be closed before installation so that no damage will occur to the disc seal. For more information please refer to page 9.
3. The pipeline should be clean of all foreign particles.
4. Locate the directional arrow on the valve body and install the valve in the pipeline with the flow arrow in the direction of flow.

For optimum performance the shaft side of the disc indicates the high pressure side, install this towards the preferred sealing side of the pipeline. This is extremely important if the valve is to operate as a tight shut off valve.

OPERATION & MAINTENANCE MANUAL

NOTE: In specific applications the valve may be required to be installed in a reverse flow condition to meet tight shut-off. If this is required it may be identified by a tag on the valve (special installation instructions). Please ensure you read the section "Installation Instructions for Special Applications".

Valve should be installed with the shaft in a horizontal plane, to reduce axial loading on components and prevent debris build-up in the lower bearing area. However, the valve can be installed in a vertical or angular orientation, if so desired.

CRYOGENIC VALVES are normally installed at a minimum of 30° to horizontal.

5. INSTALLATION INSTRUCTIONS FOR SPECIAL APPLICATIONS

In specific applications the valve may be required to be installed in a reverse flow condition, to meet tight shut-off requirements.

If the valve is installed in a downstream pump isolation application; when valve is closed it prevents flow or pressure from going back to the pump. In this case the valve should be installed with the low pressure side of the valve on the pump side (reverse to flow on the downstream side of pump).

If there is any doubt on which way to install Score-TRICENTRIC® valves, please contact the Score-TRICENTRIC® distributor that has supplied the valve or contact the factory.

6. The valve must be installed so that pipeline stresses are not transmitted to the valve body. Despite its solid manufacture, such stress may affect the valve operation. If pipeline stresses are severe, they should be cushioned by expansion joints or compensators. If supports are necessary for the valve, they should only support the dead weight of the valve and should not serve as base points for the pipeline.
7. Centre valve between flanges to prevent damage to disc or shaft which would be caused by the disc striking the pipe wall.
8. Install valve with a 1/8 thick flange gasket centered on each face. Compress the gasket uniformly by following the sequence illustrated below, for tightening of flange bolts. This **sequence** is applicable to all valve sizes, regardless of the number of bolts.

MAXIMUM FLANGE BOLT TORQUE TABLE

Nominal Bolt Dia.	Threads per Inch	Torque (ft-lbs)* Dry	Torque (ft-lbs)* Lubricated
5/8	11	110	80
3/4	10	190	140
7/8	9	310	230
1	8	460	340
1 1/8	8	660	490
1 1/4	8	900	670
1 3/8	8	1200	900
1 1/2	8	1560	1160
1 5/8	8	1980	1480
1 3/4	8	2470	1850
1 7/8	8	3030	2270

* Source: Atwood & Morrill Nuclear Division.

Actual torque requirement will depend on gasket type and fastener type used. These values are a recommended maximum not to be exceeded.

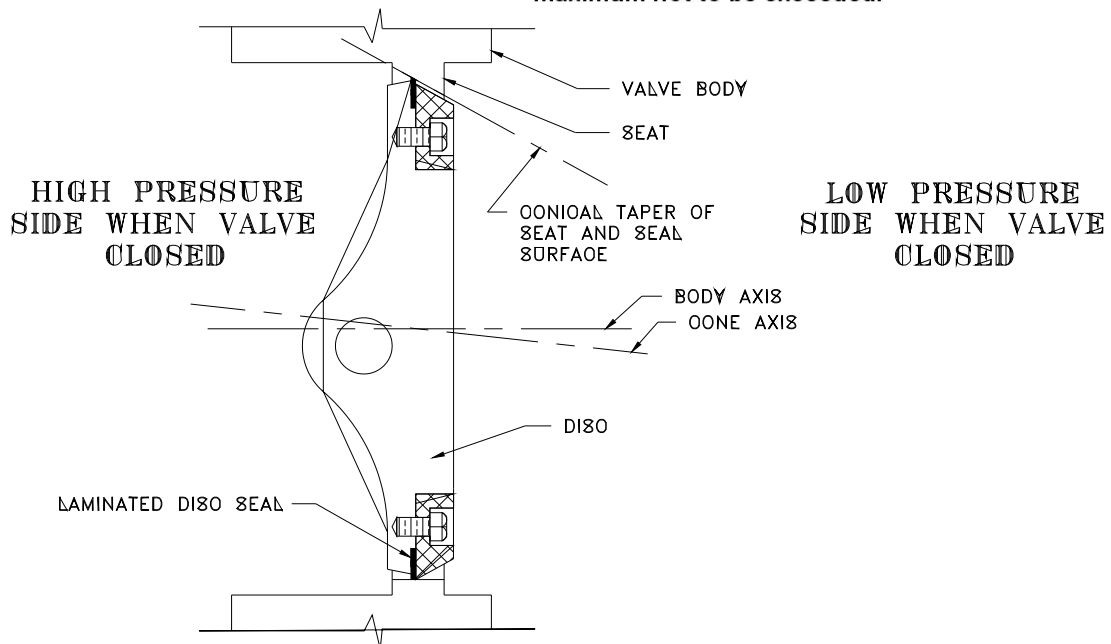

TORQUE SEQUENCE

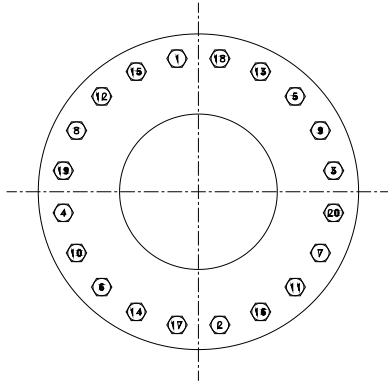

MAINTENANCE Refer to Parts Map for numbers in ().

General routine maintenance consists of tightening down the packing gland (8) periodically to compensate for packing wear. Do not tighten the packing gland too severely as this will result in excessive gland pressure and reduce the packing service life. Gland studs are to be tightened in an opposing and proportionate manner until no leakage can be detected. For details on tightening live loaded packing, refer to section on "Changing the Packing".

More extensive maintenance such as disc seal, bearing, and packing replacement is described below.

Valve Removal

- **Read the cautions section thoroughly!**
- Valve must be fully closed before removing it from the pipeline.

CAUTION: Valves equipped with fail-open (air-to-close) actuators must be disconnected from the actuators and then closed, or there must be sufficient air pressure supplied to the actuator to close the valve while removing it from the pipeline. After valve removal, slowly relieve pressure in the actuator. Line pressure should be relieved before removal of actuator.

DISC SEAL REPLACEMENT PROCEDURE

If the sealing system is suspected of unacceptable leakage, remove the valve from the line and the following simple checks can be made to determine if the disc seal must be replaced.

Check the appearance of the seal:

- Are there nicks in the metal laminations?
- Are the gasket laminations damaged, torn or broken?
- Is the seal stack (the system of the metal gasket laminations) bent or dented?

If any of the above conditions exist, SCORE recommends that the seal and gasket be replaced. If it has been determined that the seal stack must be replaced, the following steps must be followed. It is not necessary to completely disassemble a Score-TRICENTRIC® valve to replace the disc seal.

NOTE: Before starting seal removal operation, observe the clamp ring and seal stack orientation with respect to the disc. The long axis of the elliptical seal has one end that is angled greater than the other with respect to the disc face. (See Figure 1) It is important to understand this so proper reassembly can be accomplished to match the identical valve seat configuration.

The following procedure for disc seal replacement will require that a careful study of the valve assembly drawing be made by any maintenance personnel before attempting seal replacement. Good mechanical practices should be followed at all times to reduce the possibility of equipment damage or personal injury.

1. Removal of Clamp Ring

With the disc in the closed position, remove all of the disc bolts, with the exception of two bolts located on the disc (A2 centre line). These bolts should be located 180 degrees apart on this centre line. To remove the clamp ring, the valve disc will need to be in position B or position C.

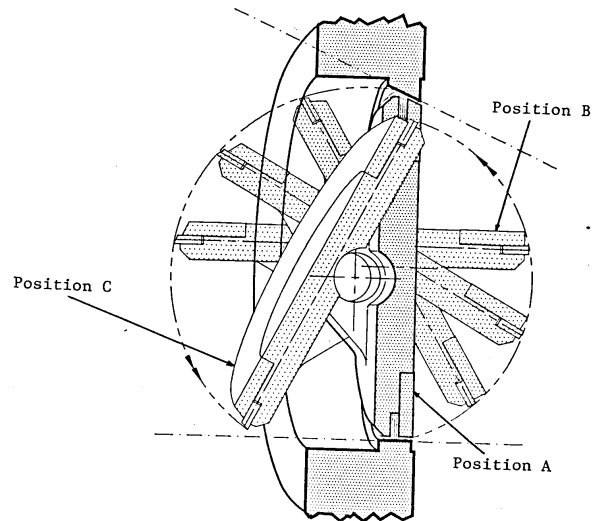

Position A is the valve fully closed. Position B is the disc in the full open position, 90 degrees from closed. Position C is the disc assembly rotated as far from closed as the valve body will allow. In most cases, Position B is the orientation the disc will be in to remove the clamp ring and seal stack. However, various sizes of Score-TRICENTRIC® valves require the disc to be in Position C for seal removal, due to insufficient clearance between the seat and clamp ring. A quick visual check of the disc in Position B will indicate if the disc should be rotated to Position C. Any actuator will have to be removed prior to moving the disc to Position C, as this travel path will exceed the limits of the actuator.

Remove the remaining bolts from the clamp ring. Lift the clamp ring off the seal (a flat tool wedged between the clamp ring and seal may be required).

Do not attempt to remove the clamp ring thru the seat side of the body. Caution must be taken to assure that the valve body seat is not damaged. If seat damage occurs the valve will need to be returned to the factory for repairs.

2. Removal of Seal Stack

With the clamp ring off and set aside, the seal stack is in full view. Notice how the seal stack is oriented, the angled sealing surface slopes down and out on the side with the greater angle. The side with the lesser angle slopes down and in. (See Figure 1) This is important to understand because it is possible to install the new seal stack upside down. Lift the seal stack off the disc and set aside. In all cases the gasket under the seal stack will need to be replaced. Remove any gasket remaining on the disc before a new seal assembly is used.

3. Installing New Seal Stack

Check the fit of the new seal on the disc. Position the seal on the disc so that one point of the seal I.D. (on the seal centre line perpendicular to the shaft axis) is touching one point of the O.D. of the seal step on the disc. (See Figure 2) There should be a space of 1/16 to 1/8 inch minimum between the disc and the seal, 180 degrees away from the contact point. (This loose fitting condition is important in the operation known as "floating" of the disc seal. This topic of floating will be described in the following paragraph.)

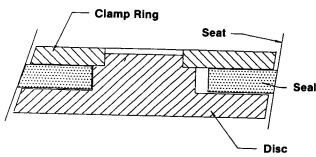

FIGURE 1

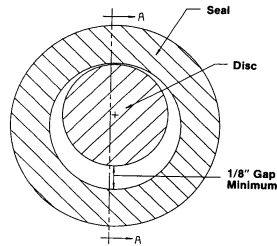

FIGURE 2

A light test of the seal/seat interface should be performed at this time to determine if the seal is centered in the seat cone. The best location for the light source is the shaft side of the disc. When there is light indications present, open the disc and rotate the seal slightly and repeat. Some experimentation will be required to determine the best direction to move the seal for centering. Once it has been determined that the best fit has been achieved, match mark the location of the seal on the disc face and open the disc fully.



Installing the Gasket

Remove the seal and place the new gasket on the disc. Position the new gasket of equal thickness as that removed on the disc step and centre the gasket around the hub. Mark the overhang. Trim flush to disc O.D. Any exposed gasket could interfere with proper seal function.

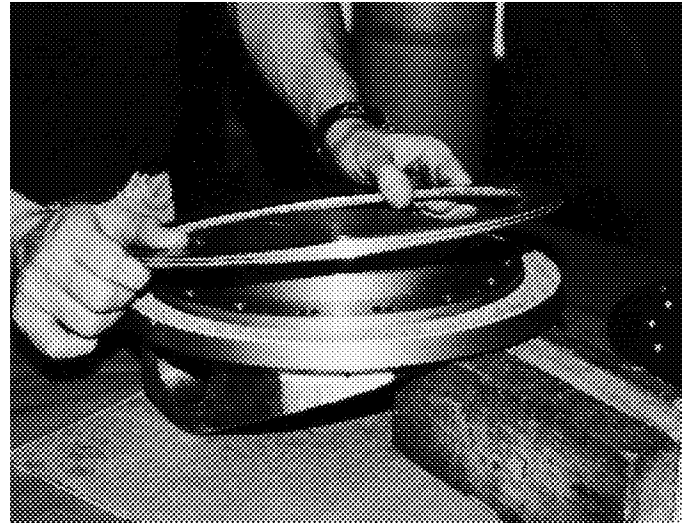

Installing the Seal Stack

RE-INSTALL THE SEAL STACK.

Due to material thickness variations of replacement seal stacks the seal and gasket combination may not be thick enough to allow clamping to occur. If this is the case, add a sufficient amount of gasket, of the same material type, under the clamp ring where it will contact the seal stack. **Do not add the additional gasket between the disc and the seal.** Trim the additional gasket in the same manner as the gasket that is between the disc and seal stack.

RE-INSTALL CLAMP RING

Place the clamp ring in the proper orientation, then install the bolting and hand tighten. Minimum clamp ring side gasket required should be used to maintain no protrusion above the raised face. Use of gasketing on centre hub should be confirmed with Score Energy.



Installing the Clamp Ring

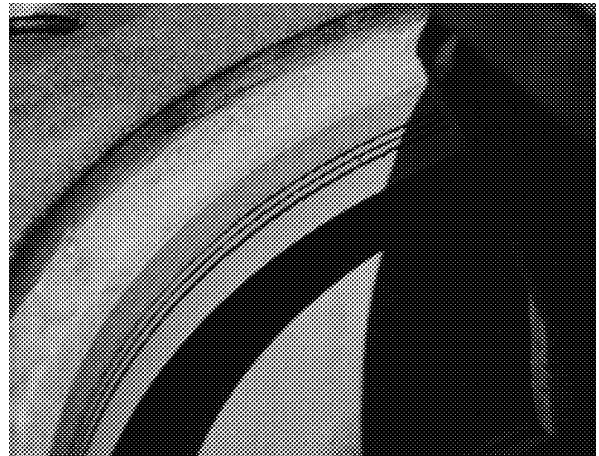

Seal Impression on Seat

Close the valve fully, applying torque to the valve shaft. Fully open the valve and visually check the impression left by the seal stack. If it is continuous and unbroken, the seal replacement is complete. If the pattern is not complete, repeat the process again.

When there is no indication left by the seal stack on the area of the seat that is located by the shaft bores, this is an indication that the gasket used between the seal stack and the disc is not thick enough to allow the seal and seat machined cones to meet when the valve is closed. This is due to variations in the material thickness of the seal stack. If this condition exists, replace the gasket with the next available thickness and repeat all of the above steps. When gaskets were used to increase clamping action, they may now have to be removed. Some determination is required, depending upon the gap between the seal and the seat, as to determining the correct thickness of the gasket that would be required to correct this situation.

It is recommended to check any gaps between the seal and seat with a feeler gauge and start with a gasket approximately two and one half times greater than the gap found. If there is a gap in the indication left on the seat at the A2, both top and bottom and the seal has not traveled to true parallel with valve face, this is the indication of excessive gasket between the seal and the disc. Replace the gasket with the next lower thickness and repeat all above steps. Again, when the contact pattern is continuous and unbroken, the floating operation is complete and the valve is ready for reinstallation. Follow the recommendations for installation.

Peening of the 3" CL150 and CL300 disc integral stud should be done only after full results are achieved. Proceed as follows:

Use a centre punch of 1/4 inch in diameter that has a point ground to a 90 degree included angle. Peen the stud in a manner sufficient to deform the stud and retain the fastener in place. This peening must be in a minimum of three (preferably 4) places equally spaced around the stud. The correct spacing of the centre punch is 1/8 inch less than the radius of the disc stud. It is recommended that the mechanic practice on a separate part until the results are acceptable.

4. Floating the Disc Seal

The word floating is used to describe the operation of getting the disc seal to self-centre in the seat ring of the valve body. This is accomplished by the fact that the ID. of the seal is large enough to allow the seal to move freely and self-centre, allowing the matching machined cones of the seat and seal to mate properly.

With the clamp ring fasteners hand tightened, open and close the valve disc three or four times, make sure the valve is seated each time. Approximately one quarter of the valves seating torque is required for a successful floating operation. On the last closing leave the disc in the closed position. Tighten the clamp ring fasteners in a crisscross torquing pattern as per torque procedure (page 11). Once the torquing of the clamp ring fasteners is complete, open the valve disc.

1/4 - 20	80 in./lb max.
5/16 - 18	140 in./lb max.
3/8 - 16	250 in./lb max.
7/16 - 14	400 in./lb max.
1/2 - 13	550 in./lb max.
5/8 - 11	100 ft./lb max.
3/4 - 10	130 ft./lb max.

NOTE:

These values are for fasteners of 316 stainless steel material and shall be used for higher strength materials of bolting. If lower strength material is used, it's corresponding torque values will determine the maximum torque to apply.

VALVE DISASSEMBLY

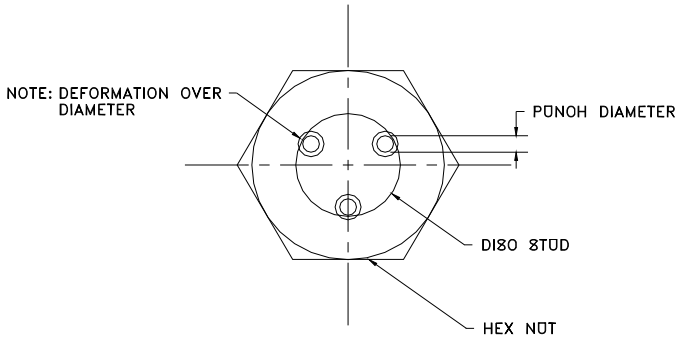

NOTE - If complete disassembly becomes necessary, replacement of all spare parts is recommended. The valve must be in the closed position during disassembly. See exploded view of valve for recommended spare parts and quantities on the parts map located on the back cover of this leaflet.

Special design - Due to the variety of options and special designs, the valve specific assembly drawing must be referenced for construction details. If no drawing is available, contact the factory for a copy.

CHANGING THE PACKING.

Changing of the packing can be made without removing the valve actuator.

1. Depressurize the valve.
2. Remove all of the nuts from the studs holding the packing gland.

NOTE - If the valve includes live loaded packing option, then the Belleville washers, flat washers and spacer will also be removed.

3. Pull back the packing gland on the shaft. The packing is now accessible. (A flexible screw hook is needed to pull packing out of the bore, one at a time.)

NOTE - If the rings used are not split, the actuator will have to be removed from the valve.

4. Install new packing, one at a time, rotating the splices at 120° intervals. Use the packing gland to push each layer of packing evenly into bore. Once packing is installed the gland can be tightened down with the nuts, using an alternate uniform tightening.

NOTE - If the valve includes live loaded packing option, then reinstall bottom flat washer, Belleville washers, spacer, then top flat washer before installing hex nut. Tighten down the nuts, using an alternate uniform tightening until resistance is felt from "bottoming" out on the spacers, do not tighten beyond "bottoming" out.

5. It is important that the packing gland follower is symmetrically mounted around the shaft. This will prevent galling on the shaft, or binding during operations.

1. Place valve on working space shaft side up.
2. Restrain the valve disc from opening by clamping, or bolting, a suitably sized square bar across the flange face, directly above the edge of the disc that is furthest away from the centre of the drive shaft. Care should be taken to prevent damage to the gasket face. Choose a correct length for a jack screw, or hydraulic jack, to place between the disc and bar. Place the jack screw in position and apply enough force to mechanically maintain the disc in place. It is not necessary to apply excessive force to maintain position. Remove the actuator and any spline adaptor, or adaptor sleeve, from the drive shaft. Remove any actuator adaptor plate or housing from the valve.
3. Remove the spring or dowel pin (52) attaching the disc to the shaft by gripping the pin with locking pliers or drill the pin out. If the pin must be removed by drilling, care should be taken not to enlarge the hole.

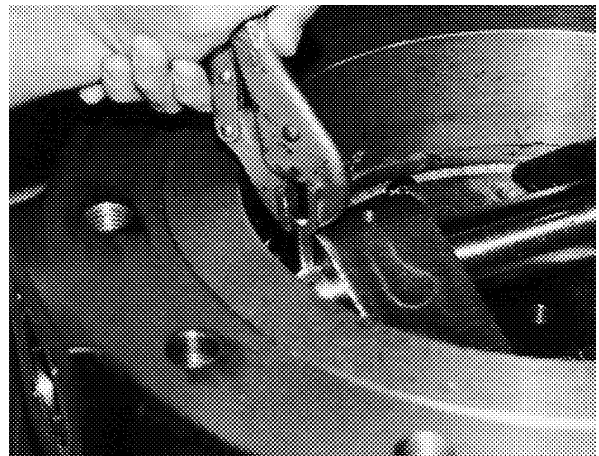

4. Remove hex head cap screws (44.2), o-ring or gasket (31), and cover plate (7) from the non-driven side of the valve body.
5. Some Score-TRICENTRIC® valves come equipped with a double stuffing box. If this is the case, remove the hex nuts and the gland follower. Remove the packing rings. There may be a snap ring retaining the annular key. Remove the snap ring at this time.

OPERATION & MAINTENANCE MANUAL

- Remove the packing gland (8), packing set (22, 23), the hex nuts (41), and studs (40).

NOTE - If the valve includes live loaded packing option, then the Belleville washers, flat washers and spacer will also be removed.

- Use a soft rod and hammer to tap the drive end of shaft (11). While pushing shaft (11) through the body (1) and disc (5), remove the annular key (28) from the non-driven end of shaft and the disc key (27) from the shaft and disc ear. Some valves have multiple keys. (Refer to valve specific assembly drawing)

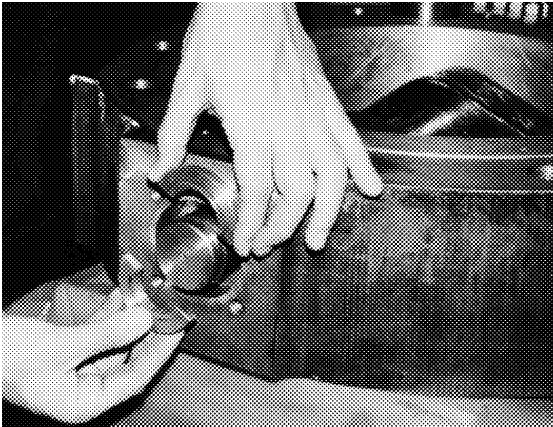

- After removing shaft, lift disc from body. (For disassembly of disc (5), clamp ring (6) and seal stack (14, 15) see Disc Seal Replacement Procedure). Great care must be taken not to damage the seal

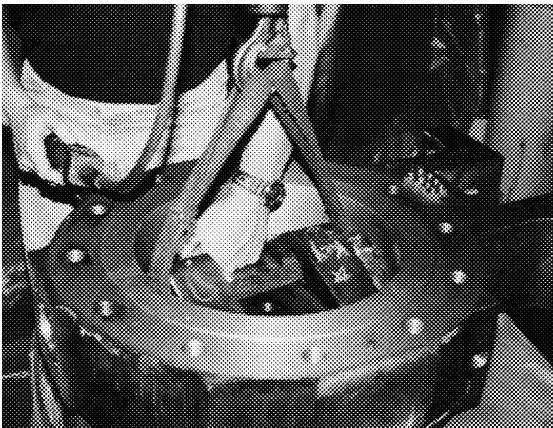

- Valve assemblies with a heat or cryogenic extension, must have extension removed at this time by removing the fasteners (44.5, 48.5) mounting the extension to the body. Remove the spacer (81) and spiral wound gasket (35) (refer to the valve specific assembly drawing or following figure for details).

- With a soft rod and hammer remove the bearings (16) by tapping them outward from the inside of the body (1).

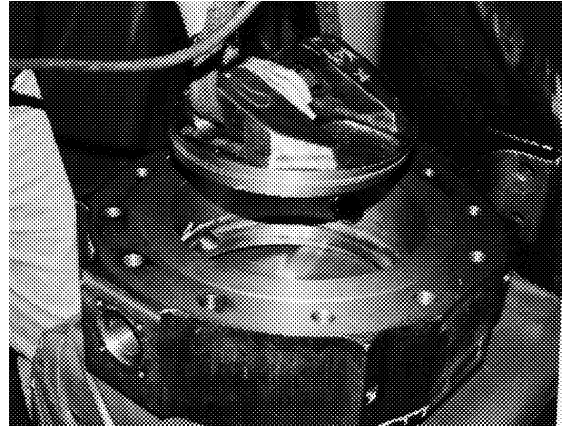

- Valve disassembly is now complete. Inspect and store all parts as previously stated.

Score-TRICENTRIC®

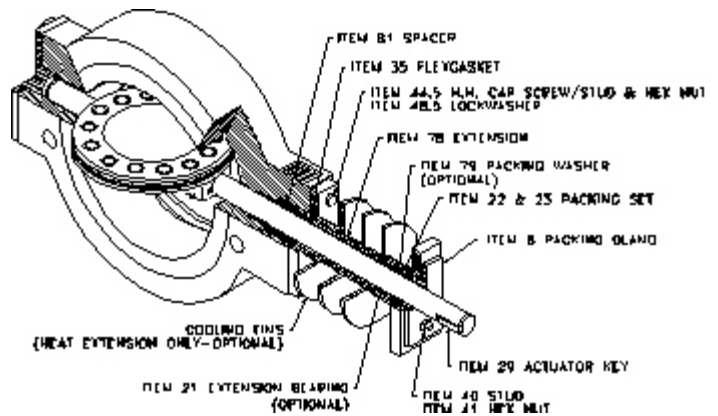

VALVE ASSEMBLY

- Clean all valve components.
- Inspect all components for damage before starting to assemble the valve. Look especially for damage to sealing areas on the disc seal, valve body seating area, shaft, and for wear in the bearing areas of the shaft and body.
- Coat shaft and disc bore lightly with lubricant compatible to fluid being handled by valve. Reverse valve disassembly procedures making sure seal is not forced in to the seat in any way.
- Cover plate and extension (if applicable) cap screws are to be tightened opposite successively and proportionately to the values specified on page 11.

Pneumatic Fail Open Service

WARNING - Extreme care must be taken in handling a valve when no actuator is mounted to restrict the disc motion.

Equipment damage or personal injury may result if the valve is mishandled. It is not recommended to mount the actuator and pressurize the cylinder to close the valve before the valve assembly is installed; due to the chance of losing pressure in the cylinder, and causing the valve to open before the valve is fully installed.

1. Install the packing and tighten until there is sufficient pressure applied to the valve shaft to retain the disc in the closed position for installation into the pipeline.
2. Install the valve in the desired position and bolt in place. Note the position of the drive key on the shaft and it's relation to the closed disc.
3. Use an appropriate tool of sufficient size to open the valve until the disc is rotated 90 degrees from the closed position. Use the shaft drive key location in positioning the disc. Note: It is possible to over travel the disc in the open position. Do not exceed 90 degrees travel.
4. Confirm that the tag number on the valve matches the tag number on the actuator (if applicable).
5. With the actuator return spring fully relaxed, note the orientation of the parallel key way in the bore of the actuator in relation to the drive keys of the actuator bushing and the valve shaft. Install the actuator bushing on the drive shaft and position it to fully engage the bore of the actuator.
6. Mount the adaptor plate to either the valve body or the actuator, depending upon the restrictions of the bolting. In most cases, the adaptor plate is mounted at the factory and properly torqued in place.
7. Restrain the yoke of the actuator with the stop screw opposite the spring canister. (Refer to the actuator drawing for details). It may be necessary to move the yoke into alignment via this set screw. Confirm that the keyway aligns with the valve assembly as close as possible. Install the actuator onto the drive shaft of the valve and confirm that the assembly is correctly positioned to the desired orientation.
8. Check the position of the actuator bolt holes for alignment. Again, it may become necessary to use the open stop screw to align the bolt holes. Install the bolting and torque in place.
9. Back out the close stop screw several turns. Connect the air supply and pressurize the actuator to close the valve. Move the close stop screw in until it engages the internal yoke of the actuator, then back the screw out ¼ to ½ turn and lock the close stop screw in place. This will assure that the full torque output of the actuator is transferred to the seal system of the valve.

10. Allow the actuator to travel to the open position by relieving the air pressure in the cylinder. Adjust the open stop set screw to restrict the disc to 90 degrees travel. Repeat these last two steps until it is assured that there is no mechanical restriction on the actuator that would interfere with the valve torque seating or stopping at 90 degrees travel to full open. Installation is now complete. Consult with your Quality Control department to assure that the valve assembly installation is correct.

11. Do not over pressurize the cylinder. Refer to the manufacturer's manual.

Actuator Safety

Manual Gear Actuators - Do not use a cheater bar to force the handwheel. Excessive torque may cause damage to the valve or valve actuator.

Electric Motor Operated Manual Gear Operator - Reverse rotation of the valve control motor eliminates the protection of both the geared limit switch and the torque switch. This will damage the actuator and possibly the valve assembly. Prior to electrical installation, move the valve to mid-position by the handwheel. The torque switch is adjusted at the factory and it is not recommended that the adjustment be changed without consulting the factory. When operating the actuator, confirm that the actuator rotates the disc in the proper direction, the torque switch is operating correctly and that the close stop set screw does not interfere with torque seating the valve. Also confirm that the open and closed limit switches operate at the proper disc position. **Do not force the handwheel!**

Pneumatic Actuator - Do not exceed the maximum operating pressure prescribed by SCORE, to the actuator.

CAUTION - SPRING RETURN MODELS

Upon loss of air supply, the valve will fail open or closed, depending upon type. Personal injury may result if body extremities are in the path of the disc travel.

In all cases, adequate protection should be provided to insure that no operating personnel could be hurt by the valve closure.

Actuator Maintenance

Separate actuator manuals are supplied. Please refer to this manual if maintenance is to be performed.

TROUBLE SHOOTING

If a handwheel is unusually hard to turn:

- check valve for improper lubrication or damage.
- ensure that the valve packing is not binding on the drive shaft.
- check for faulty or damaged valves parts or obstructions.

If any questions arise, consult with Score Energy Products Inc. at [780] 466-6782.

OPERATION & MAINTENANCE MANUAL

PROCEDURE FOR TORQUING THREADED FASTENERS

- ▶ This procedure applies to valves manufactured by Score Energy Products at its Edmonton, Alberta plant.
- ▶ This procedure shall be used to verify proper torque application to threaded fasteners used in assembly of valves.

Equipment Required - Torque wrenches. These may be dial indicator type or click-type and calibrated per prescribed procedure.

PROCEDURE

Assembly

Assemble threaded fasteners to mating parts as indicated on the assembly drawing and run down to finger tightness. Using a torque wrench apply approximately 75% of the torque specified on the torque chart, in a uniform manner (criss-cross rather than in adjacent sequence), then the balance of the torque in two or three equal increments, also in a uniform manner, to within ± 10 in.lb.

Testing

Using a torque wrench in a uniform manner (criss-cross) apply torque to the fastener, within ± 5%. Hydro test after completion of torque sequence.

Final Inspection

Using a torque wrench in a uniform manner (criss-cross) verify torque requirements within ± 5% of tabulated values.

TORQUE GUIDE

SCORE ENERGY PRODUCTS INC ©1997

Maximum Suggested Assembly Torque Values (Dry Condition)							
Size	316 SST¹	A320Gr.L7 A193 G B7²	SAE Gr 5¹	A193 Gr B8M³	MONEL 400¹	INCONEL 600¹	A320 Gr.L7M A193 Gr.B7M
1/4 - 20	79 lb-in	141 lb-in	108 lb-in	55 lb-in	85 lb-in	95 lb-in	-
5/16 - 18	138 lb-in	23 lb-ft	205 lb-in	110 lb-in	149 lb-in	144 lb-in	-
3/8 - 16	21 lb-ft	41 lb-ft	31 lb-ft	194 lb-in	22 lb-ft	25 lb-ft	-
½ - 13	45 lb-ft	98 lb-ft	75 lb-ft	39 lb-ft	49 lb-ft	55 lb-ft	73 lb-ft
5/8 - 11	97 lb-ft	195 lb-ft	150 lb-ft	78 lb-ft	111 lb-ft	124 lb-ft	146 lb-ft
3/4 - 10	130 lb-ft	339 lb-ft	265 lb-ft	137 lb-ft	149 lb-ft	167 lb-ft	260 lb-ft
7/8 - 9	202 lb-ft	543 lb-ft	430 lb-ft	219 lb-ft	230 lb-ft	258 lb-ft	419 lb-ft
1 - 8	271 lb-ft	817 lb-ft	645 lb-ft	331 lb-ft	311 lb-ft	348 lb-ft	629 lb-ft
1 1/8 - 8	415 lb-ft	1163 lb-ft	800 lb-ft	477 lb-ft	470 lb-ft	526 lb-ft	925 lb-ft
1 1/4 - 8	504 lb-ft	1596 lb-ft	1120 lb-ft	661 lb-ft	575 lb-ft	644 lb-ft	1303 lb-ft
1 3/8 - 8	600 lb-ft	2125 lb-ft	1470 lb-ft	886 lb-ft	690 lb-ft	773 lb-ft	1770 lb-ft
1 1/2 - 8	732 lb-ft	2758 lb-ft	1950 lb-ft	1360 lb-ft	840 lb-ft	941 lb-ft	2337 lb-ft

NOTE:

1. Torque values based on data from BOWMAN Fasteners Facts.
2. Torque values based on body thread shear stress at 120% of the design stress intensity value.
3. Torque values based on fastener shear stress at 120% of the design stress intensity value.
4. Hex jam nut torque valves are 70% of valves listed.

ANSI FLANGE BOLT DIMENSIONS FOR TRICENTRIC® LUG STYLE BUTTERFLY VALVES

OL 150				
VALVE SIZE	BOLTS NOT ADJAOENT TO SHAFT		BOLTS ADJAOENT TO SHAFT	
	QTY.	BOLTING DATA	QTY.	BOLTING DATA
3	8	5/8-11 UNO x 2" LG.	—	—
4	16	5/8-11 UNO x 2" LG.	—	—
6	16	3/4-10 UNO x 2 1/4" LG.	—	—
8	16	3/4-10 UNO x 2 1/4" LG.	—	—
10	24	7/8-9 UNO x 2 1/2" LG.	—	—
12	24	7/8-9 UNO x 2 1/2" LG.	—	—
14	24	1-8 UN x 2 3/4" LG.	—	—
16	28	1-8 UN x 2 3/4" LG.	4	1-8 UN x 2 5/8" LG.
18	28	1 1/8-8 UN x 3 1/4" LG.	4	1 1/8-8 UN x 3" LG.
20	36	1 1/8-8 UN x 3 1/4" LG.	4	1 1/8-8 UN x 2 7/8" LG.
24	40	1 1/4-8 UN x 3 1/2" LG.	—	—
30	48	1 1/4-8 UN x 4 3/4" LG.	8	1 1/4-8 UN x 4 1/4" LG.
36	56	1 1/2-8 UN x 5 1/2" LG.	8	1 1/2-8 UN x 5 1/8" LG.
42	64	1 1/2-8 UN x 5 3/4" LG.	8	1 1/2-8 UN x 5 1/2" LG.
48	80	1 1/2-8 UN x 6 1/4" LG.	8	1 1/2-8 UN x 6" LG.
54	88	1 3/4-8 UN x 5 1/4" LG.	—	—
60	96	1 3/4-8 UN x 5 1/2" LG.	8	1 3/4-8 UN x 5 1/4" LG.
64	104	1 1/4-8 UN x 6" LG.	—	—
72	116	1 3/4-8 UN x 6" LG.	4	1 3/4-8 UN x 5 1/2" LG.

OL 600				
VALVE SIZE	BOLTS NOT ADJAOENT TO SHAFT		BOLTS ADJAOENT TO SHAFT	
	QTY.	BOLTING DATA	QTY.	BOLTING DATA
3	—	—	—	—
4	—	—	—	—
6	20	1-8 UN x 3 3/8" LG.	4	1-8 UN x 3" LG.
8	20	1 1/8-8 UN x 3 7/8" LG.	4	1 1/8-8 UN x 3 1/2" LG.
10	28	1 1/4-8 UN x 4 1/4" LG.	4	1 1/4-8 UN x 3 7/8" LG.
12	36	1 1/4-8 UN x 4 7/16" LG.	4	1 1/4-8 UN x 4 1/16" LG.
14	36	1 3/8-8 UN x 4 11/16" LG.	4	1 3/8-8 UN x 4 1/4" LG.
16	36	1 1/2-8 UN x 5 1/16" LG.	4	1 1/2-8 UN x 4 9/16" LG.
18	36	1 5/8-8 UN x 5 7/16" LG.	4	1 5/8-8 UN x 5 7/16" LG.
20	44	1 5/8-8 UN x 5 11/16" LG.	4	1 5/8-8 UN x 5 11/16" LG.
24	44	1 7/8-8 UN x 6 7/16" LG.	4	1 7/8-8 UN x 6" LG.

OL 300				
VALVE SIZE	BOLTS NOT ADJAOENT TO SHAFT		BOLTS ADJAOENT TO SHAFT	
	QTY.	BOLTING DATA	QTY.	BOLTING DATA
3	12	3/4-10 UNO x 2 1/4" LG.	4	3/4-10 UNO x 2" LG.
4	16	3/4-10 UNO x 2 3/8" LG.	—	—
6	20	3/4-10 UNO x 2 1/2" LG.	4	3/4-10 UNO x 2 1/4" LG.
8	20	7/8-9 UNO x 2 7/8" LG.	4	7/8-9 UNO x 2 3/4" LG.
10	28	1-8 UN x 3 1/8" LG.	4	1-8 UN x 2 13/16" LG.
12	28	1 1/8-8 UN x 3 1/2" LG.	4	1 1/8-8 UN x 3 3/8" LG.
14	32	1 1/8-8 UN x 3 3/4" LG.	8	1 1/8-8 UN x 3 3/8" LG.
16	32	1 1/4-8 UN x 4" LG.	8	1 1/4-8 UN x 3 5/8" LG.
18	48	1 1/4-8 UN x 4" LG.	—	—
20	40	1 1/4-8 UN x 4 1/4" LG.	8	1 1/4-8 UN x 4" LG.
24	40	1 1/2-8 UN x 4 3/4" LG.	8	1 1/2-8 UN x 4 3/8" LG.
30	56	1 3/4-8 UN x 6" LG.	—	—
36	64	2-8 UN x 6 3/4" LG.	—	—
42	64	1 5/8-8 UN x 7" LG.	—	—

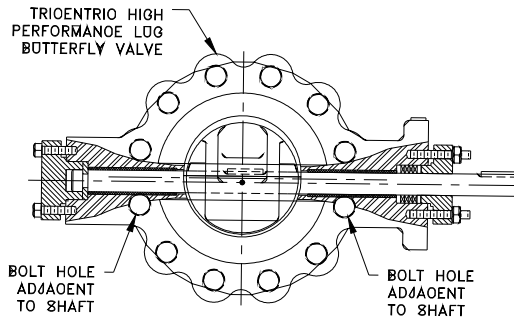

1. BOLT LENGTHS CALCULATED BASED ON:

- A. FLANGE DIMENSIONS - 3" TO 24" VALVES PER ANSI B16.5.
- 30" TO 48" PER ANSI B16.47 SERIES A.
- 54", 60" & 72" PER ANSI B16.1 OL125,
64" PER SHELL STANDARD.
- B. 1/8" THICK FLANGE GASKET.
- C. BOLT THREAD END CHAMFER OF 1/2 OF ONE THREAD INCLUDED IN SPECIFIED LENGTH.
- D. LENGTH TOLERANCE: + 0", - 1/16".

NOTE: QUANTITIES SHOWN ARE FOR BOTH FLANGE FACES.

ANSI FLANGE BOLT DIMENSIONS FOR TRICENTRIC® WAFER STYLE BUTTERFLY VALVES

CL 150						
VALVE SIZE	FLANGE STUDS REQUIRED		HEX NUTS REQUIRED		BOLTS ADJAOENT TO SHAFT	
	QTY.	STUD BOLT DATA	QTY.	HEX NUTS DATA	QTY.	BOLTING DATA
3	4	5/8-11 ONO x 5 3/4" LG.	8	5/8	—	—
4	6	5/8-11 ONO x 6" LG.	12	5/8	4	5/8-11 ONO x 2" LG.
6	8	3/4-10 ONO x 6 1/2" LG.	16	3/4	—	—
8	8	3/4-10 ONO x 7" LG.	16	3/4	—	—
10	12	7/8-9 ONO x 7 1/2" LG.	24	7/8	—	—
12	12	7/8-9 ONO x 8 1/4" LG.	24	7/8	—	—
14	12	1-8 ON x 9 1/4" LG.	24	1	—	—
16	14	1-8 ON x 9 1/2" LG.	28	1	4	1-8 ON x 2 5/8" LG.
18	14	1 1/8-8 ON x 10 1/2" LG.	28	1 1/8	4	1 1/8-8 ON x 3" LG.
20	18	1 1/8-8 ON x 11 1/2" LG.	36	1 1/8	4	1 1/8-8 ON x 2 7/8" LG.
24	16	1 1/4-8 ON x 13" LG.	32	1 1/4	8	1 1/4-8 ON x 3 1/2" LG.
30	24	1 1/4-8 ON x 15" LG.	48	1 1/4	8	1 1/4-8 ON x 4 1/4" LG.
36	28	1 1/2-8 ON x 19 1/4" LG.	56	1 1/2	8	1 1/2-8 ON x 5 1/8" LG.
42	32	1 1/2-8 ON x 20 1/2" LG.	64	1 1/2	8	1 1/2-8 ON x 5 1/2" LG.
48	40	1 1/2-8 ON x 22 1/2" LG.	80	1 1/2	8	1 1/2-8 ON x 6" LG.
54	40	1 3/4-8 ON x 22 3/4" LG.	80	1 3/4	8	1 3/4-8 ON x 5 1/4" LG.
60	48	1 3/4-8 ON x 24 1/2" LG.	96	1 3/4	8	1 3/4-8 ON x 5 1/4" LG.
72	56	1 3/4-8 ON x 26 1/2" LG.	112	1 3/4	8	1 3/4-8 ON x 5 1/2" LG.

CL 300						
VALVE SIZE	FLANGE STUDS REQUIRED		HEX NUTS REQUIRED		BOLTS ADJAOENT TO SHAFT	
	QTY.	STUD BOLT DATA	QTY.	HEX NUTS DATA	QTY.	BOLTING DATA
3	6	3/4-10 ONO x 6 1/2" LG.	12	3/4	4	3/4-10 ONO x 2" LG.
4	8	3/4-10 ONO x 7" LG.	16	3/4	—	—
6	10	3/4-10 ONO x 7 1/2" LG.	20	3/4	4	3/4-10 ONO x 2 1/4" LG.
8	10	7/8-9 ONO x 8 3/4" LG.	20	7/8	4	7/8-9 ONO x 2 3/4" LG.
10	14	1-8 ON x 9 3/4" LG.	28	1	4	1-8 ON x 2 13/16" LG.
12	14	1 1/8-8 ON x 10 3/4" LG.	28	1 1/8	4	1 1/8-8 ON x 3 3/8" LG.
14	16	1 1/8-8 ON x 12" LG.	32	1 1/8	8	1 1/8-8 ON x 3 3/8" LG.
16	16	1 1/4-8 ON x 13" LG.	32	1 1/4	8	1 1/4-8 ON x 3 5/8" LG.
18	20	1 1/4-8 ON x 14" LG.	40	1 1/4	8	1 1/4-8 ON x 4" LG.
20	20	1 1/4-8 ON x 14 1/2" LG.	40	1 1/4	8	1 1/4-8 ON x 4" LG.
24	20	1 1/2-8 ON x 16 1/2" LG.	40	1 1/2	8	1 1/2-8 ON x 4 3/8" LG.
30	24	1 3/4-8 ON x 22" LG.	48	1 3/4	8	1 3/4-8 ON x 6" LG.
36	28	2-8 ON x 25 1/2" LG.	56	2	8	2-8 ON x 6 3/4" LG.
42	28	1 5/8-8 ON x 26 3/4" LG.	56	1 5/8	8	1 5/8-8 ON x 7" LG.

CL 600						
VALVE SIZE	FLANGE STUDS REQUIRED		HEX NUTS REQUIRED		BOLTS ADJAOENT TO SHAFT	
	QTY.	STUD BOLT DATA	QTY.	HEX NUTS DATA	QTY.	BOLTING DATA
3	—	—	—	—	—	—
4	—	—	—	—	—	—
6	10	1-8 ON x 10 1/4" LG.	20	1	4	1-8 ON x 3" LG.
8	10	1 1/8-8 ON x 11 3/4" LG.	20	1 1/8	4	1 1/8-8 ON x 3 1/2" LG.
10	12	1 1/4-8 ON x 13 3/4" LG.	24	1 1/4	8	1 1/4-8 ON x 3 7/8" LG.
12	16	1 1/4-8 ON x 15 1/2" LG.	32	1 1/4	8	1 1/4-8 ON x 4 1/16" LG.
14	16	1 3/8-8 ON x 16 1/4" LG.	32	1 3/8	8	1 3/8-8 ON x 4 1/4" LG.
16	16	1 1/2-8 ON x 17 1/4" LG.	32	1 1/2	8	1 1/2-8 ON x 4 9/16" LG.
18	16	1 5/8-8 ON x 19" LG.	32	1 5/8	8	1 5/8-8 ON x 5 7/16" LG.
20	20	1 5/8-8 ON x 20" LG.	40	1 5/8	8	1 5/8-8 ON x 5 11/16" LG.
24	20	1 7/8-8 ON x 22 1/4" LG.	40	1 7/8	8	1 7/8-8 ON x 6" LG.

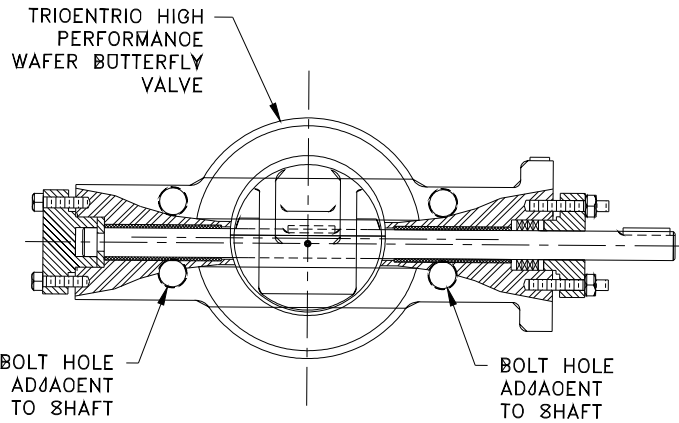

1. BOLT LENGTHS CALCULATED BASED ON:
- A. FLANGE DIMENSIONS - 3" TO 24" VALVES PER ANSI B16.5.
- 30" TO 48" PER ANSI B16.47 SERIES A.
- 54" AND UP PER ANSI B16.1 CL125.
 - B. 1/8" THICK FLANGE GASKET.
 - C. STUD THREAD END CHAMFER EXCLUDED IN SPECIFIED LENGTH.
 - D. BOLT THREAD END CHAMFER OF 1/2 OF ONE THREAD INCLUDED IN SPECIFIED LENGTH.
 - E. BOLT LENGTH TOLERANCE: + 0", - 1/16".
 - F. NUTS SPECIFIED ARE STANDARD HEAVY HEX NUTS TO ANSI B16.2.2
 - G. STUD BOLT LENGTH TOLERANCE: FOR UP TO 12" LONG + 0", - 1/16".
12" TO 18" LONG + 0", - 1/8".
OVER 18" LONG + 0", - 1/4".

NOTE: QUANTITIES SHOWN ARE FOR BOTH FLANGE FACES.

ANSI FLANGE BOLT DIMENSIONS FOR TRICENTRIC® DOUBLE FLANGE STYLE BUTTERFLY VALVES

OL 150						
VALVE SIZE	FLANGE STUDS REQUIRED		HEX NUTS REQUIRED		BOLTS ADJAOENT TO SHAFT	
	QTY.	STUD BOLT DATA	QTY.	HEX NUTS DATA	QTY.	BOLTING DATA
3	8	5/8-11 ONO x 3 1/2" LG.	16	5/8	—	—
4	8	5/8-11 ONO x 3 1/2" LG.	16	5/8	8	5/8-11 ONO x 1 3/4" LG.
6	8	3/4-10 ONO x 4" LG.	16	3/4	8	3/4-10 ONO x 2" LG.
8	8	3/4-10 ONO x 4 1/4" LG.	16	3/4	8	3/4-10 ONO x 2" LG.
10	16	7/8-9 ONO x 4 1/2" LG.	32	7/8	8	7/8-9 ONO x 2 1/4" LG.
12	16	7/8-9 ONO x 4 3/4" LG.	32	7/8	8	7/8-9 ONO x 2 3/8" LG.
14	16	1-8 ON x 5 1/4" LG.	32	1	8	1-8 ON x 2 1/2" LG.
16	24	1-8 ON x 5 1/4" LG.	48	1	8	1-8 ON x 2 5/8" LG.
18	24	1 1/8-8 ON x 5 3/4" LG.	48	1 1/8	8	1 1/8-8 ON x 3" LG.
20	32	1 1/8-8 ON x 6 1/4" LG.	64	1 1/8	8	1 1/8-8 ON x 3" LG.
24	32	1 1/4-8 ON x 6 3/4" LG.	64	1 1/4	8	1 1/4-8 ON x 3 3/8" LG.
30	48	1 1/4-8 ON x 9" LG.	96	1 1/4	8	1 1/4-8 ON x 4 1/2" LG.
36	56	1 1/2-8 ON x 10 3/4" LG.	112	1 1/2	8	1 1/2-8 ON x 5 3/8" LG.
42	64	1 1/2-8 ON x 11 1/4" LG.	128	1 1/2	8	1 1/2-8 ON x 5 5/8" LG.
48	80	1 1/2-8 ON x 12 1/4" LG.	160	1 1/2	8	1 1/2-8 ON x 6" LG.
54	80	1 3/4-8 ON x 10 1/2" LG.	160	1 3/4	8	1 3/4-8 ON x 5" LG.
60	88	1 3/4-8 ON x 11" LG.	176	1 3/4	16	1 3/4-8 ON x 5 1/4" LG.
72	112	1 3/4-8 ON x 11 1/2" LG.	224	1 3/4	8	1 3/4-8 ON x 5 3/4" LG.

OL 300						
VALVE SIZE	FLANGE STUDS REQUIRED		HEX NUTS REQUIRED		BOLTS ADJAOENT TO SHAFT	
	QTY.	STUD BOLT DATA	QTY.	HEX NUTS DATA	QTY.	BOLTING DATA
3	8	3/4-10 ONO x 4 1/4" LG.	16	3/4	8	3/4-10 ONO x 2 1/8" LG.
4	8	3/4-10 ONO x 4 1/2" LG.	16	3/4	8	3/4-10 ONO x 2 1/4" LG.
6	16	3/4-10 ONO x 4 3/4" LG.	32	3/4	8	3/4-10 ONO x 2 1/2" LG.
8	16	7/8-9 ONO x 5 1/2" LG.	32	7/8	8	7/8-9 ONO x 2 3/4" LG.
10	24	1-8 ON x 6 1/4" LG.	48	1	8	1-8 ON x 3 1/8" LG.
12	24	1 1/8-8 ON x 6 3/4" LG.	48	1 1/8	8	1 1/8-8 ON x 3 3/8" LG.
14	32	1 1/8-8 ON x 7" LG.	64	1 1/8	8	1 1/8-8 ON x 3 1/2" LG.
16	32	1 1/4-8 ON x 7 1/2" LG.	64	1 1/4	8	1 1/4-8 ON x 3 3/4" LG.
18	40	1 1/4-8 ON x 7 3/4" LG.	80	1 1/4	8	1 1/4-8 ON x 4" LG.
20	40	1 1/4-8 ON x 8" LG.	80	1 1/4	8	1 1/4-8 ON x 4" LG.
24	40	1 1/2-8 ON x 9" LG.	80	1 1/2	8	1 1/2-8 ON x 4 1/2" LG.
30	48	1 3/4-8 ON x 11 1/2" LG.	96	1 3/4	8	1 3/4-8 ON x 5 3/4" LG.
36	56	2-8 ON x 13" LG.	112	2	8	2-8 ON x 6 1/2" LG.
42	56	1 5/8-8 ON x 13 1/2" LG.	112	1 5/8	8	1 5/8-8 ON x 6 3/4" LG.

OL 600						
VALVE SIZE	FLANGE STUDS REQUIRED		HEX NUTS REQUIRED		BOLTS ADJAOENT TO SHAFT	
	QTY.	STUD BOLT DATA	QTY.	HEX NUTS DATA	QTY.	BOLTING DATA
3	—	—	—	—	—	—
4	—	—	—	—	—	—
6	16	1-8 ON x 6 3/4" LG.	32	1	8	1-8 ON x 3 1/2" LG.
8	16	1 1/8-8 ON x 7 1/2" LG.	32	1 1/8	8	1 1/8-8 ON x 4" LG.
10	24	1 1/4-8 ON x 8 1/2" LG.	48	1 1/4	8	1 1/4-8 ON x 4 1/2" LG.
12	32	1 1/4-8 ON x 8 3/4" LG.	64	1 1/4	8	1 1/4-8 ON x 4 1/2" LG.
14	32	1 3/8-8 ON x 9 1/4" LG.	64	1 3/8	8	1 3/8-8 ON x 4 3/4" LG.
16	32	1 1/2-8 ON x 10" LG.	64	1 1/2	8	1 1/2-8 ON x 5 1/4" LG.
18	32	1 5/8-8 ON x 10 3/4" LG.	64	1 5/8	8	1 5/8-8 ON x 5 3/4" LG.
20	40	1 5/8-8 ON x 11 1/4" LG.	80	1 5/8	8	1 5/8-8 ON x 6" LG.
24	40	1 7/8-8 ON x 13" LG.	80	1 7/8	8	1 7/8-8 ON x 6 1/2" LG.

OL 900						
VALVE SIZE	FLANGE STUDS REQUIRED		HEX NUTS REQUIRED		BOLTS ADJAOENT TO SHAFT	
	QTY.	STUD BOLT DATA	QTY.	HEX NUTS DATA	QTY.	BOLTING DATA
3	—	—	—	—	—	—
4	—	—	—	—	—	—
6	—	—	—	—	—	—
8	16	1 3/8-8 ON x 8 3/4" LG.	32	1 3/8	8	1 3/8-8 ON x 4 1/2" LG.
10	24	1 3/8-8 ON x 9 1/4" LG.	48	1 3/8	8	1 3/8-8 ON x 4 3/4" LG.

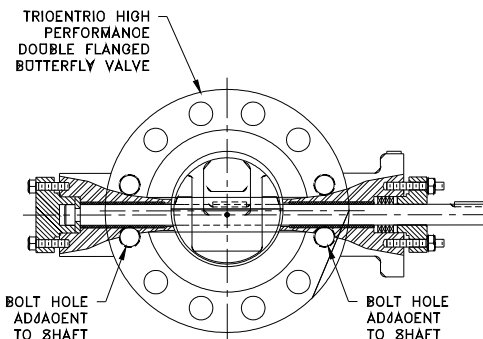

1. BOLT LENGTHS CALCULATED BASED ON:
 - A. FLANGE DIMENSIONS - 3" TO 24" VALVES PER ANSI B16.5.
 - 30" TO 48" PER ANSI B16.47 SERIES A.
 - 54" AND UP PER ANSI B16.1 CL125.
 - B. 1/8" THICK FLANGE GASKET.
 - C. STUD THREAD END CHAMFER EXCLUDED IN SPECIFIED LENGTH.
 - D. BOLT THREAD END CHAMFER OF 1/2 OF ONE THREAD INCLUDED IN SPECIFIED LENGTH.
 - E. BOLT LENGTH TOLERANCE: + 0", - 1/16".
 - F. NUTS SPECIFIED ARE STANDARD HEAVY HEX NUTS TO ANSI B18.2.2
 - G. STUD BOLT LENGTH TOLERANCE: FOR UP TO 12" LONG + 0", - 1/16".
 - 12" TO 18" LONG + 0", - 1/8".
 - OVER 18" LONG + 0", - 1/4".

NOTE: QUANTITIES SHOWN ARE FOR BOTH FLANGE FACES.

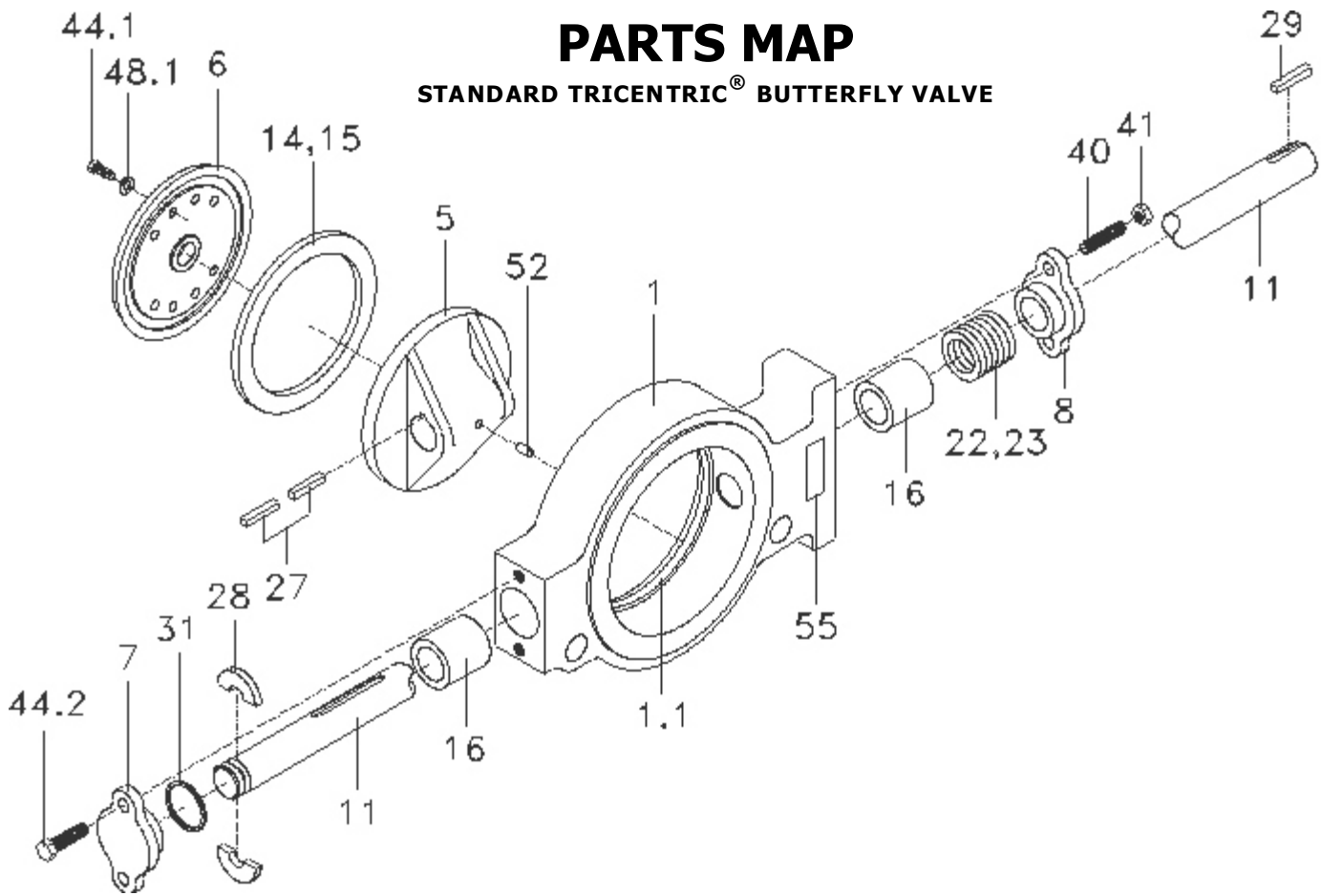

ITEM #	DESCRIPTION	QTY PER VALVE	ITEM #	DESCRIPTION	QTY PER VALVE
1	Body	1	27	Disc Key	as req'd
1.1	Seat (Integral w/body)	1	28	Annular Key	1
5	Disc	1	29	Actuator Key	1
6	Clamp Ring	1	31	Metal O-Ring	1
7	Cover Plate	1	40	Stud	as req'd
8	Packing Gland	1	41	Hex Nut	as req'd
11	Shaft	1	44.1	Disc Hex Head Cap Screw	as req'd
14	Seal Stack	1	44.2	Cover Hex Head Cap Screw	as req'd
15	Bottom Gasket	1	48.1	Disc Lock-Washer	as req'd
16	Bearing	as req'd	52	Pin	1
22	Packing Grafoil	3	55	Serial Plate	1
23	Braided End Ring	2			

TO ORDER SPARE PARTS, THE FOLLOWING INFORMATION SHOULD BE FURNISHED TO SCORE:

- A. Serial Number of valve
- B. Valve Size
- C. Quantity required
- D. Valve ANSI Class
- E. Item # and description on parts list

PARTS MAP

STANDARD Score-TRICENTRIC® BUTTERFLY VALVE WITH CRYOGENIC EXTENSION

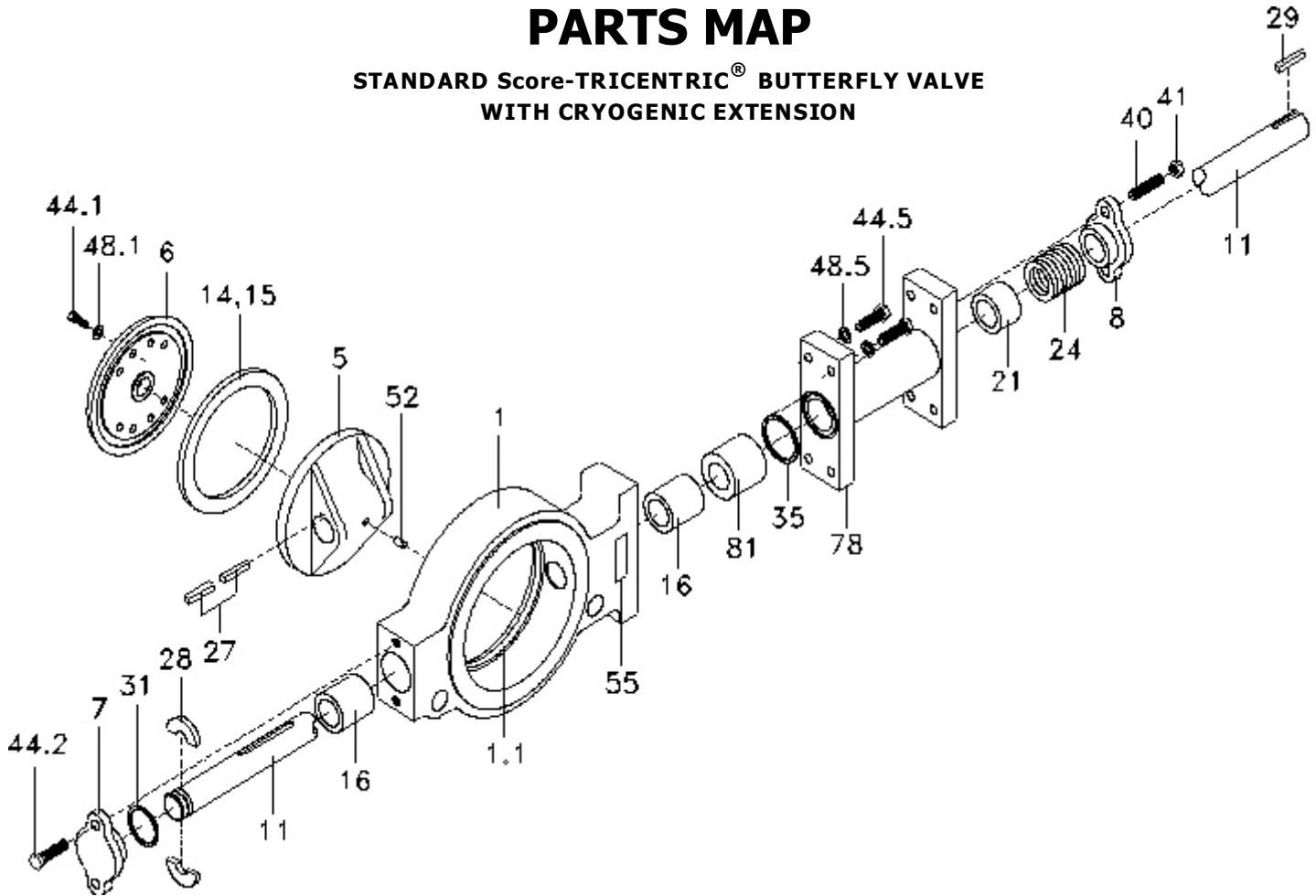

ITEM #	DESCRIPTION	QTY PER VALVE	ITEM #	DESCRIPTION	QTY PER VALVE
1	Body	1	29	Actuator Key	1
1.1	Seat (Integral w/body)	1	31	Metal O-Ring	1
5	Disc	1	35	Flexitallic Gasket	1
6	Clamp Ring	1	40	Stud	as req'd
7	Cover Plate	1	41	Hex Nut	as req'd
8	Packing Gland	1	44.1	Disc Hex Head Cap Screw	as req'd
11	Shaft	1	44.2	Cover Hex Head Cap Screw	as req'd
14	Seal Stack	1	44.5	Hex Head Cap Screw	as req'd
15	Bottom Gasket	1	48.1	Disc Lock-Washer	as req'd
16	Bearing	as req'd	48.5	Lockwasher	as req'd
21	Bearing for Cryogenic	1	52	Pin	1
24	Packing Set	1	55	Serial Plate	1
27	Disc Key	as req'd	78	Cryogenic Extension	1
28	Annular Key	1	81	Bore Spacer	1

TO ORDER SPARE PARTS, THE FOLLOWING INFORMATION SHOULD BE FURNISHED TO SCORE:

- A. Serial Number of valve
- B. Valve Size
- C. Quantity required
- D. Valve ANSI Class
- E. Item # and description on parts list